

# bosal

**Инструкция  
по монтажу тягово-сцепного  
устройства шарового типа 1219 Н  
для автомобилей  
ВАЗ - 1119  
“Калина” НВ**

	2006 -...
	900
	50
	9,1

.....  
..... VIN .....



462800,

« - »

18

∴ (35363) 7-05-06

/ ∴ (35363) 7-13-20

(495) 785-66-07

www.bosal-autoflex.ru

« - »	(8182) 22-48-15
"	" 8(8442) 98-74-98
"	" 8(343) 379-39-89, 373-42-73
"	" 8(343) 26-88-308
"	" 8(3952) 710-194
"	" 8(495) 777-54-59
"	" 8(495)745-79-11
"	" 8(495) 788-95-97
"	" 8(495) 720-51-03
"	" 8(3532) 57-99-85
"	" 8-905-899-5012
"	" 8(383) 291-59-60
"	" 8(831) 279-53-24
"	" 8(3422) 98-27-20
"	" 8(342) 220-87-87
"	" 8-927-002-90-06
"	" 8(3462) 24-00-44
"	" 8(3842) 21-14-76
"	" 8-902-940-4151
"	" 8(3452) 32-22-12, 41-52-62
"	" 8-961-213-0278
"	" 8-917-347-1700
"	" 8(351) 269-44-75, 900-72-73
"	" 8(3512) 773-76-91

41.55-2005.

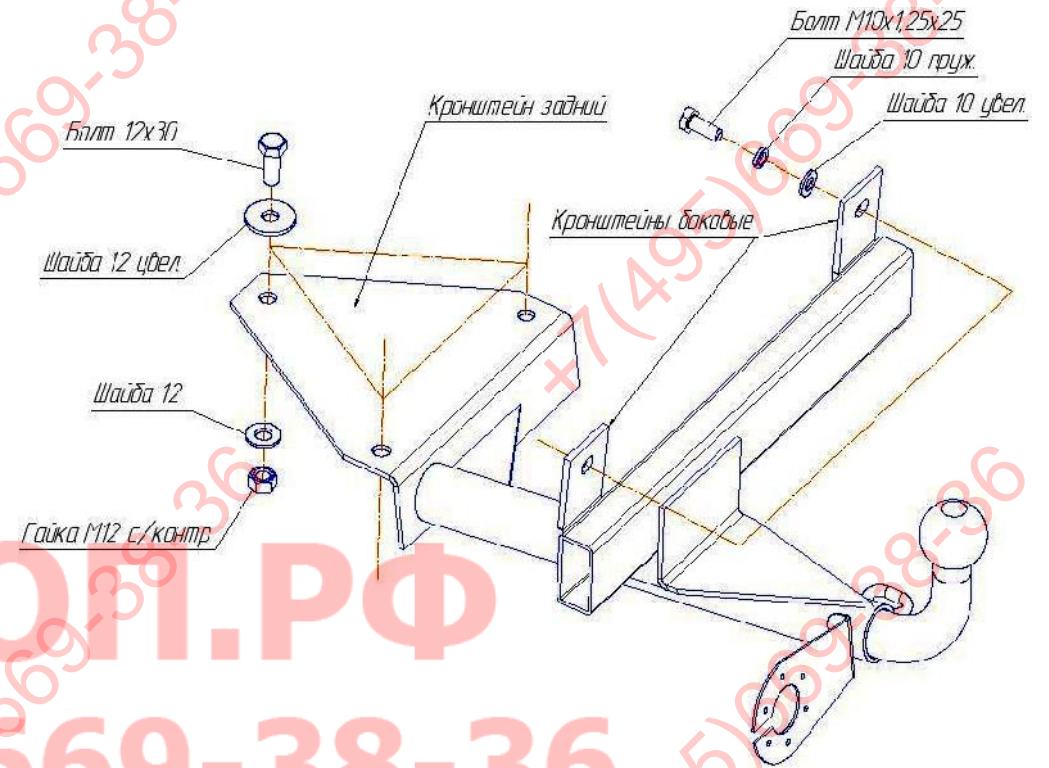

10 1,25 25.

12 30.

**ФАРКОП.РФ**

**+7 (495) 669-38-36**

	1 .
	1 .
	1 .

	1 .
2	1 .
10 1,25 25	2 .
12 30	3 .
12 ( / )	3 .
10 ( . )	2 .
10	2 .
12	7 .
12 ( . )	3 .
	1 .
	1 .
	1 .

1			
2			
3			
4			
5			
6			
7			

