

bosal

**Инструкция по монтажу
тягово-сцепного устройства
шарового типа 3040 А
для автомобилей
Toyota Land Cruiser Prado
Lexus GX 470**

ФАРКОП.РФ

+7 (495) 669-38-36

	2002/10-...
	1500
	75
	17.0

.....
..... VIN



462800,

18

:(35363) 7-05-06

/(35363) 7-13-20

(495) 785-66-07

www.bosal-autoflex.ru

« - » (8182) 22-48-15
" 8(8442) 98-74-98
" 8(343) 379-39-89, 373-42-73
" 8(343) 26-88-308
" 8(3952) 710-194
" 8(495) 777-54-59
" 8(495) 745-79-11
" 8(495) 788-95-97
" 8(495) 720-51-03
" 8(3532) 57-99-85
" 8-905-899-5012
" 8(383) 291-59-60
" 8(831) 279-53-24
" 8(3422) 98-27-20
" 8(342) 220-87-87
" 8-927-002-90-06
" 8(3462) 24-00-44
" 8(3842) 21-14-76
" 8-902-940-4151
" 8(3452) 32-22-12, 41-52-62
" 8-961-213-0278
" 8-917-347-1700
" 8(351) 269-44-75, 900-72-73
" 8(3512) 773-76-91

41.55-2005.

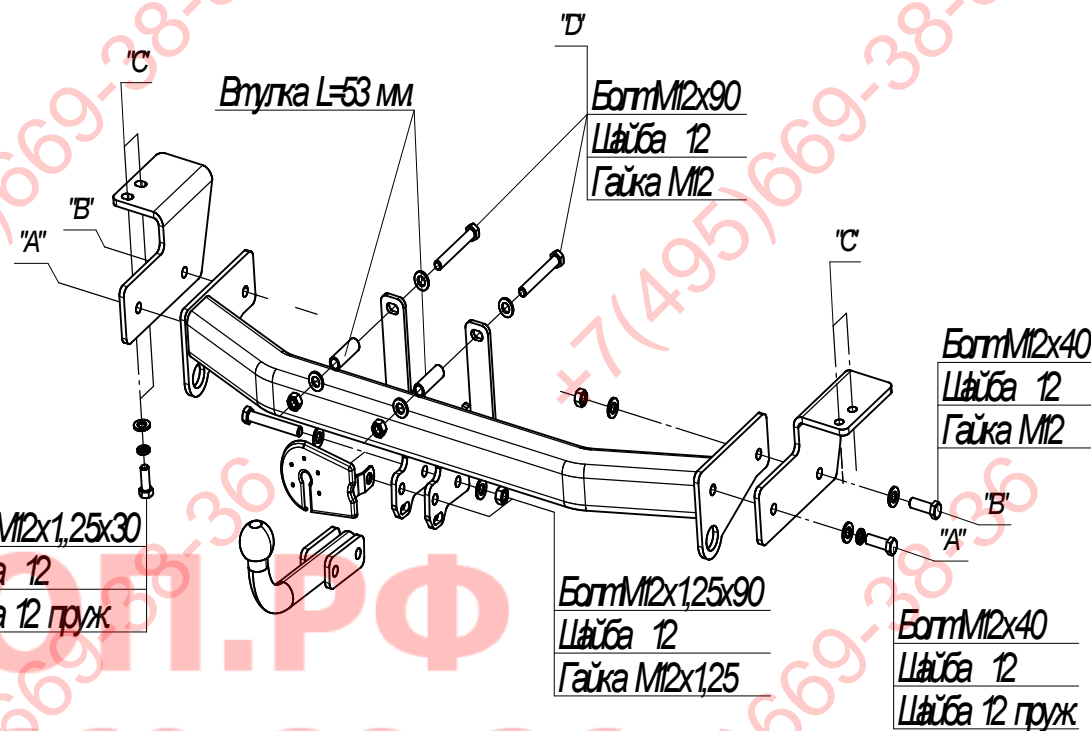

6
 ()
 Ø18
 («C»)
 12 30.
 ()
 12 90,
 6.
 6 12
 («D»)
 L=53
 («D»)

ФАРКОМ.РФ
 +7 (495) 669-38-36

	1
	1
	1
	1
	1

	3
12 1,25 /	4
12 /	2
12	18
12	6
12 1,25 30	4
12 40	4
12 1,25 90	2
12 90	2
L = 53	2
6 12 ()	2
6 . ()	2
	2
0800	1
	1
	1
	1
190	1
	1

1		
2		
3		
4		
5		
6		
7		

