

Fitting instructions

Make: Mazda

MPV LW; 2003->

Type: 4098

ФАРКОГ.РФ

+7 (495) 669-38-36

Permanently

linked to

quality

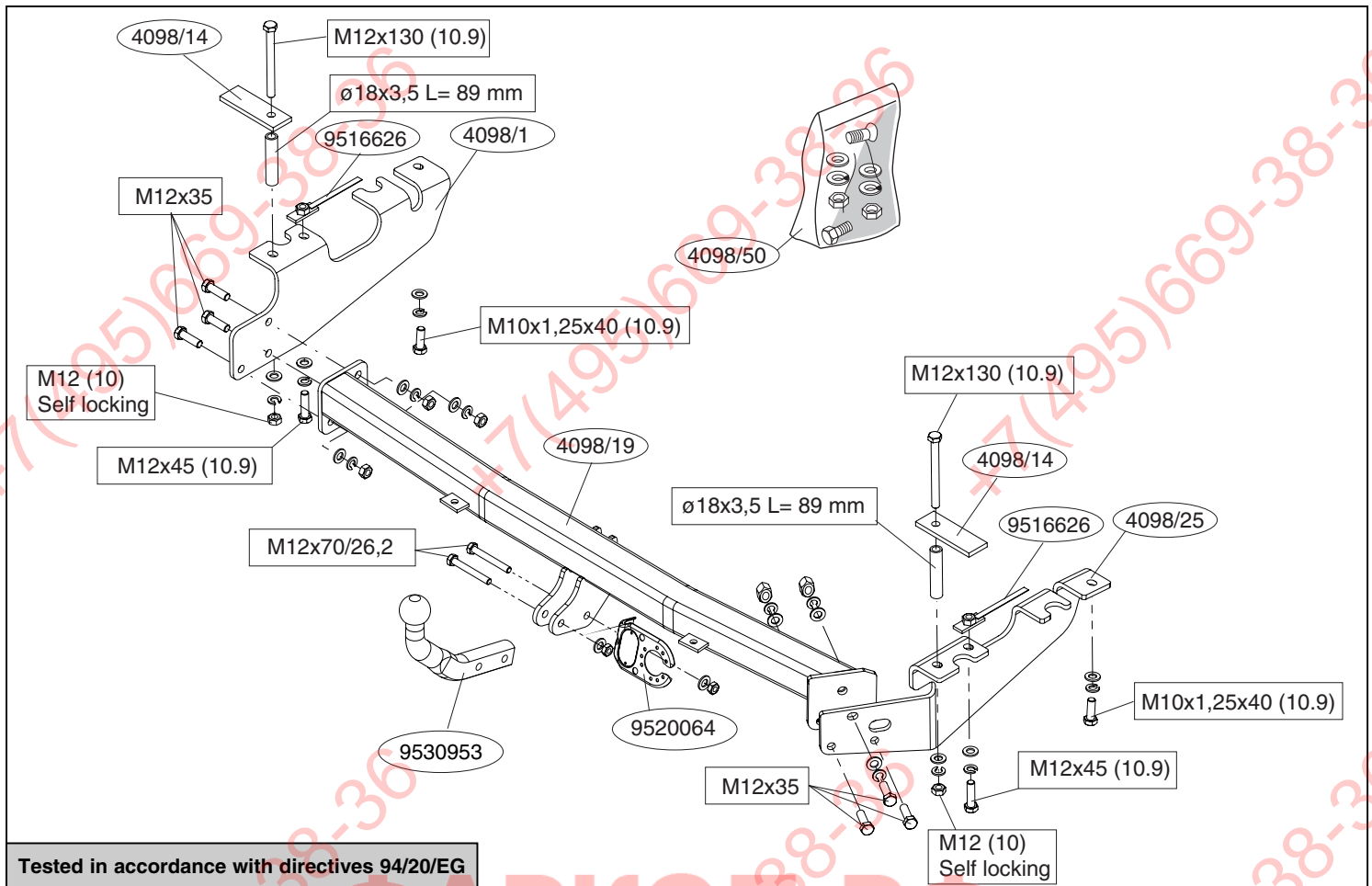

Tested in accordance with directives 94/20/EG

© 409870/04-07-2003/1

+7 (495) 669-38-36

Dispositivo di traino tipo: Brink 4098
 Per autoveicoli: Mazda MPV LW; 2003->
 Tipo funzionale: LW 6932/69R2

Classe e tipo di attacco: A50-X
 Omologazione: e11 00-4403
 Valore D: 10.8 kN
 Carico Verticale max. S: 85 kg
 Larghezza rimorchiabile per Caravan e T.A.T.S.: 2,45m vedere CARTA di CIRCOLAZIONE VEICOLO (motrice) + 70 cm = ..arrotondare ai 5 cm superiore (vedi D.M.28/05/85)
 Massa rimorchiabile: vedi carta di circolazione dell' autoveicolo

Per verificare l'idoneità del dispositivo di traino omologato a norma CEE 94/20, all'installazione sulla vettura su cui si intende procedere al montaggio, compilare la seguente formula (se necessario declassare la massa rimorchiabile):

$$D = \frac{T \times C}{T + C} \times 0,00981 = \dots\dots\dots \text{kN} < D$$

dove: T= Massa Complessiva Max. della motrice (in kg)
 C= Massa Rimorchiabile Max. della motrice (in kg)

DA COMPILARE PER IL COLLAUDO

DICHIARAZIONE DI CORRETTO MONTAGGIO: la sottoscritta Ditta dichiara di aver montato in maniera corretta ed in conformità alle prescrizioni sia del costruttore del veicolo che del costruttore del dispositivo stesso il seguente dispositivo di attacco meccanico:

tipo:.....
 Il dispositivo di attacco sopra indicato è stato installato su autoveicolo
 modello:.....
 targa:.....
 Data:.....

TIMBRO e FIRMA

Si dichiara inoltre di aver informato l'utente del veicolo sull'USO e MANUTENZIONE del dispositivo stesso.

© 409870/04-07-2003/14

(5x) M12 (8.8)		(2x) M10x1,25x40 (10.9)	
(2x) M12 (10) self-locking		(2x) M12x70/26,2 (8.8)	
(2x) M12 (8.8) self-locking		(2x) M12x45 (10.9)	
(2x) M10		(6x) M12x35 (8.8)	
(10x) M12		(2x) M12x130 (10.9)	
(2x) M10			
(2x) M12			
(2x) M10			
(12x) M12			

(2x) ø18x3,5 L=89mm

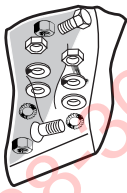
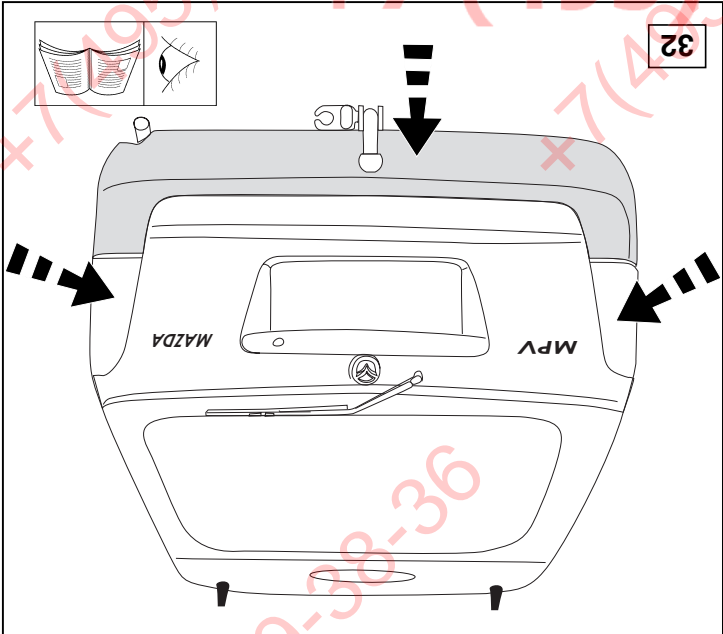
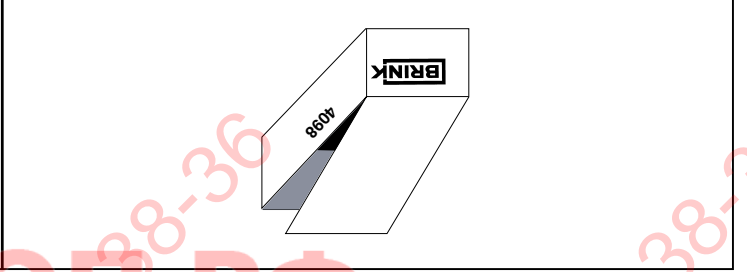
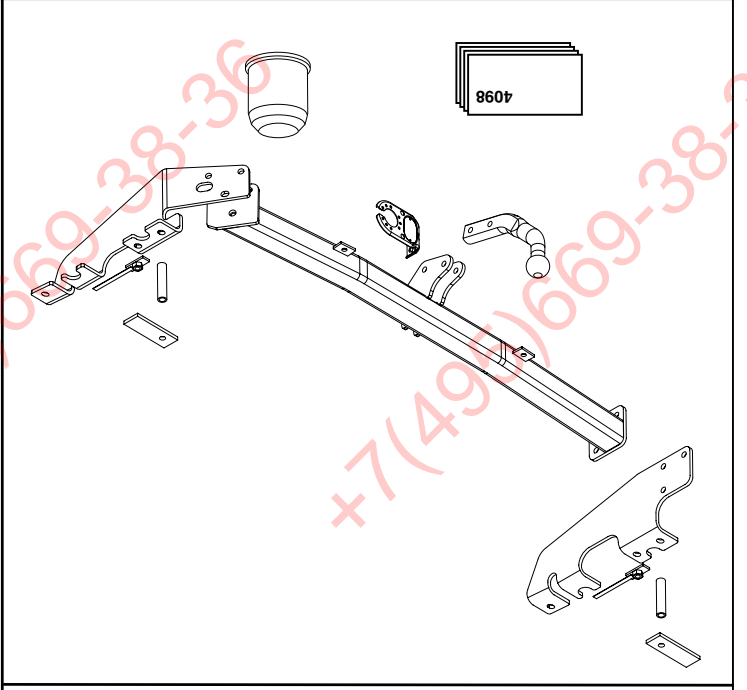
31

(2x) M12 (8.8)	
(2x) M12	
(2x) M12 x70/26,2 (8.8)	

self locking

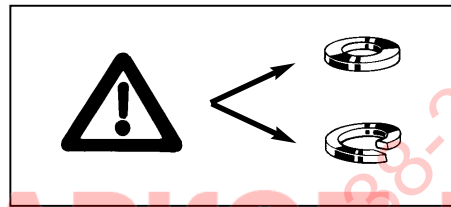
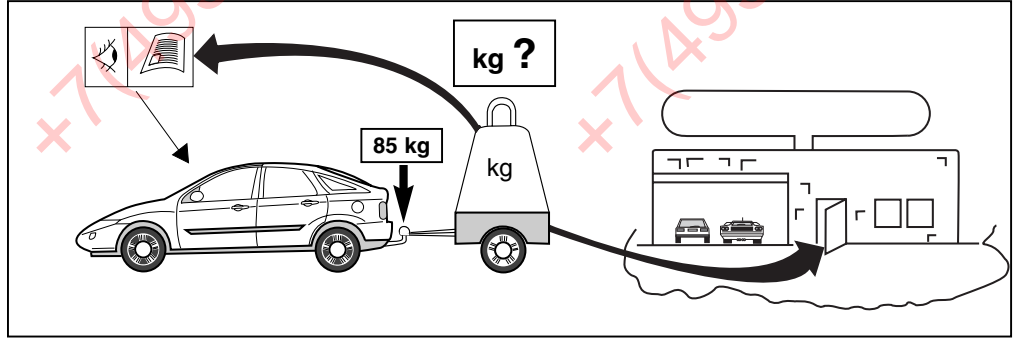
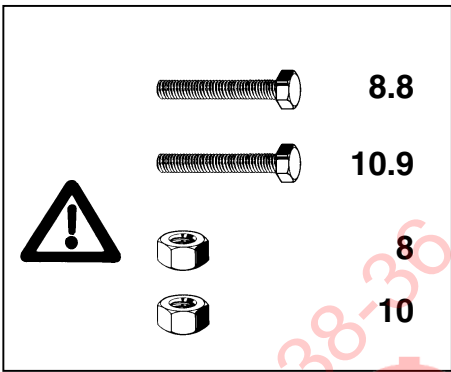
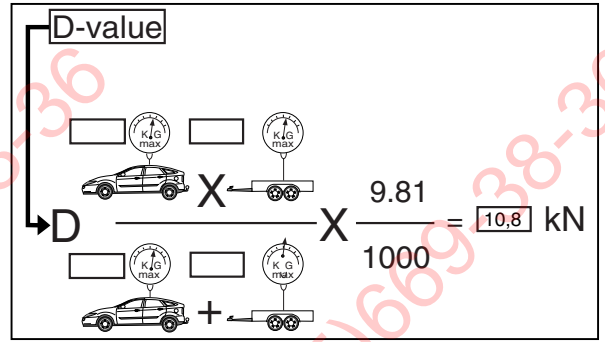
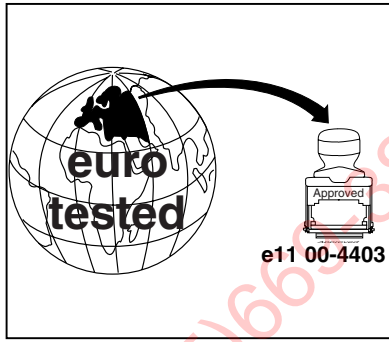
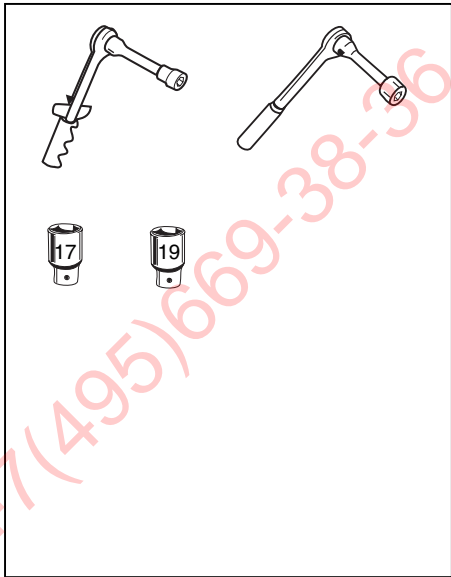

ФАРКОП.РФ

© 409870/04-07-2003/3

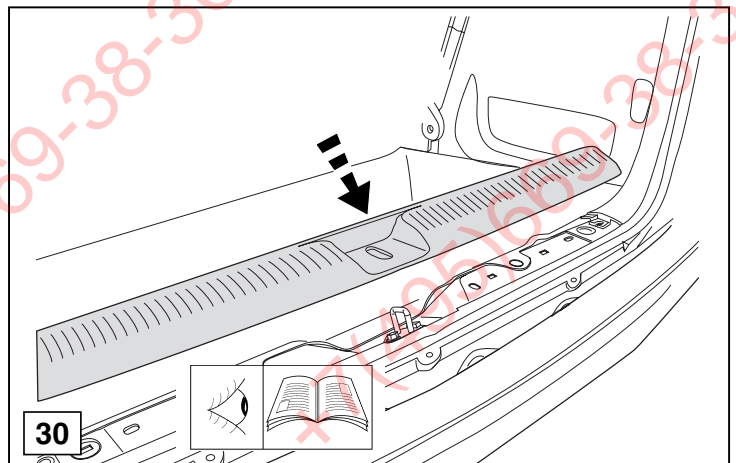
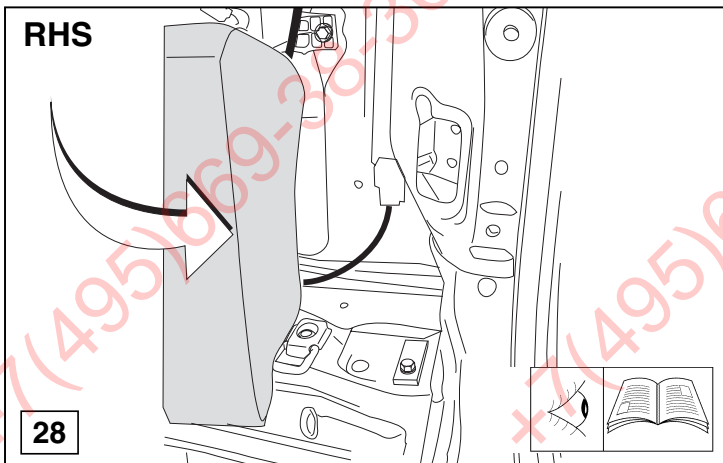
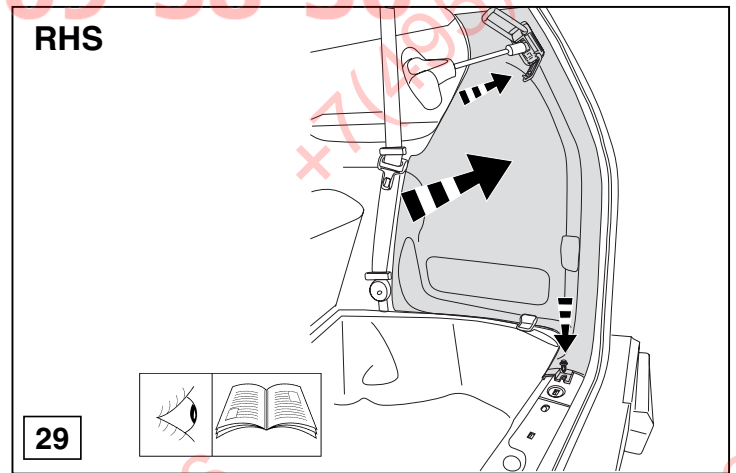
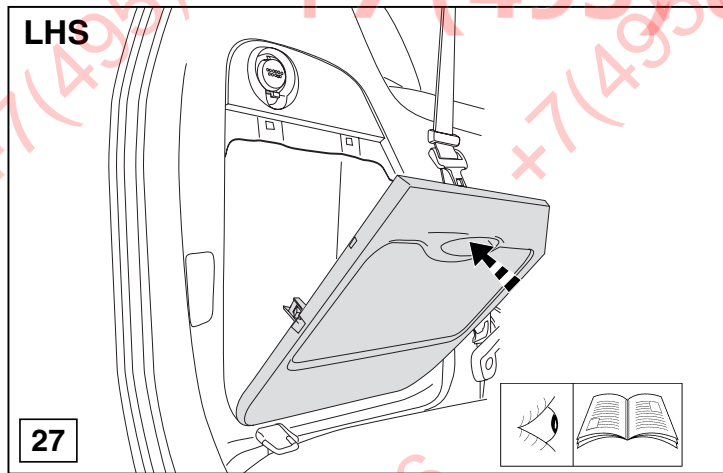

© 409870/04-07-2003/12

* Die für das Fahrzeug zugelassene Anhängelast ist den Fahrzeug Unterlagen zu entnehmen. Bei Änderungen des Fahrzeuggewichtes muß die höchstzulässige Anhängelast gegebenenfalls aus dem D-Wert nachgerechnet werden.
 * Auskunft hierfür kann Ihr Fachhändler oder der TÜV geben.
 * Elektrische Anlage gemäß StVZO anbringen.

HINWEISE:

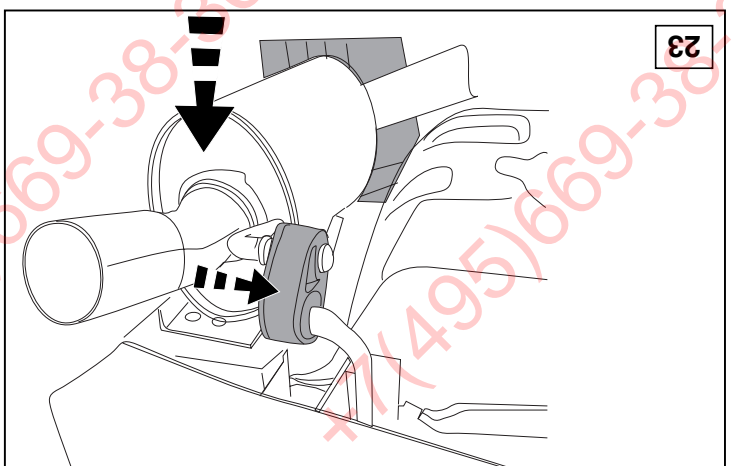
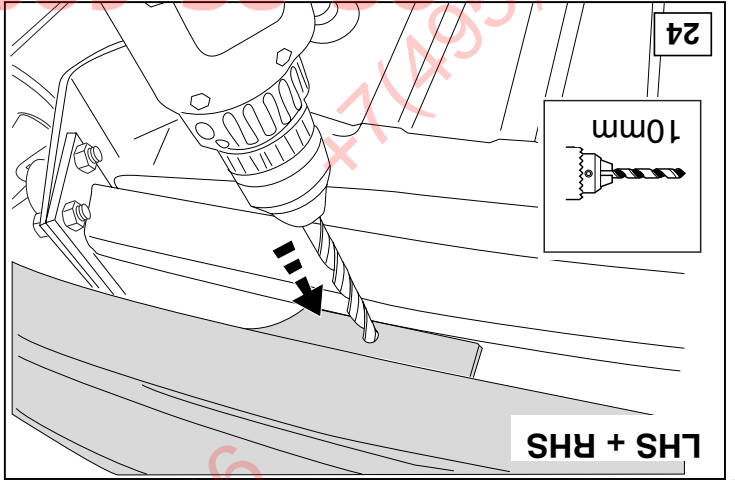
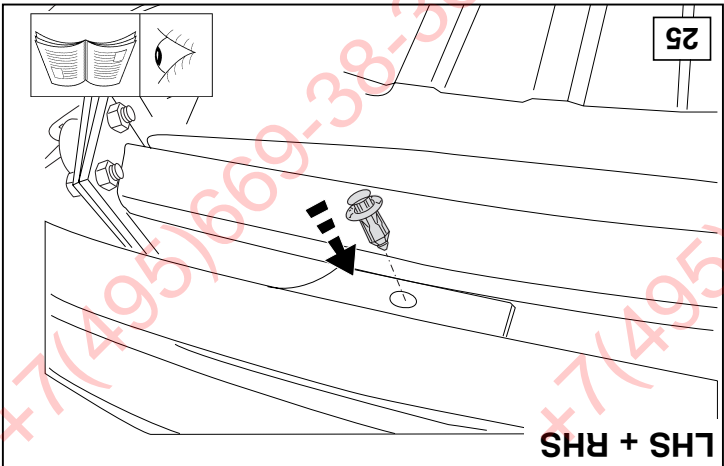
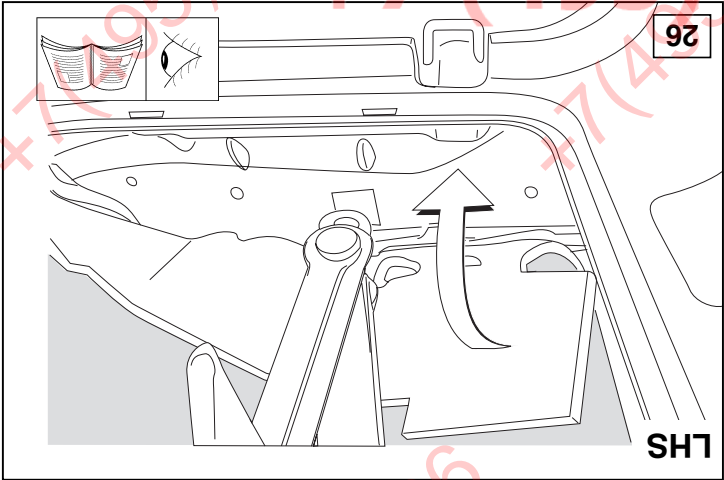

1000km

+

0km

M12
95 Nm

M10x1,25
60 Nm

Torque settings for nuts and bolts (10.9)

M12
79 Nm 71 Nm (with self-locking nut)

Torque settings for nuts and bolts (8.8)

ΦΑΡΚΟΠ.ΡΦ

+7 (495) 669-38-36

+7 (495) 669-38-36

+7 (495) 669-38-36

+7 (495) 669-38-36

+7 (495) 669-38-36

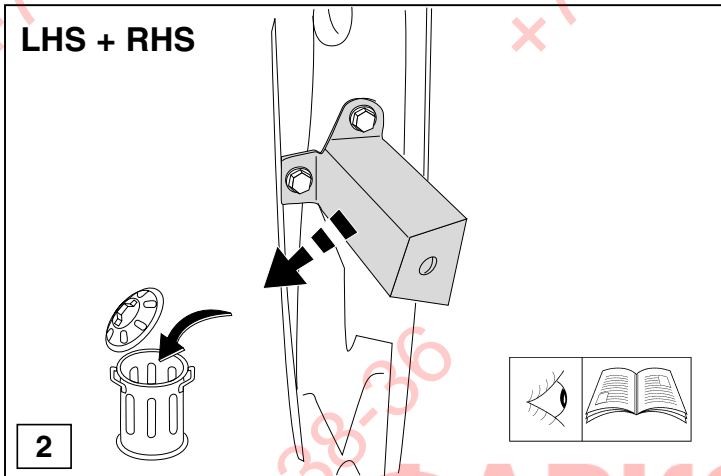
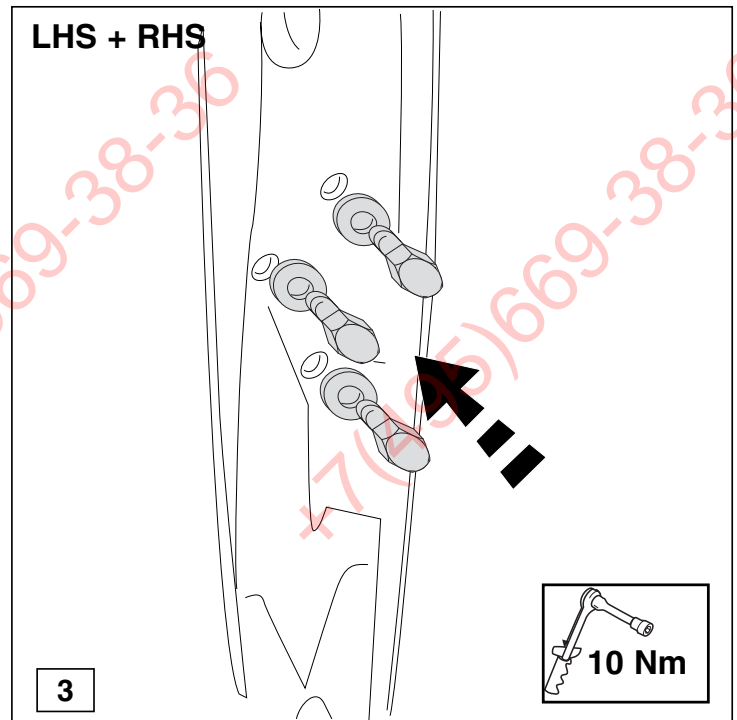
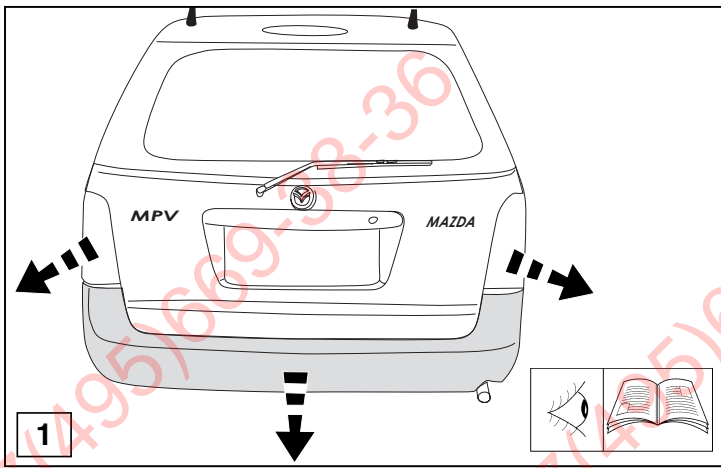

© 409870/04-07-2003/5

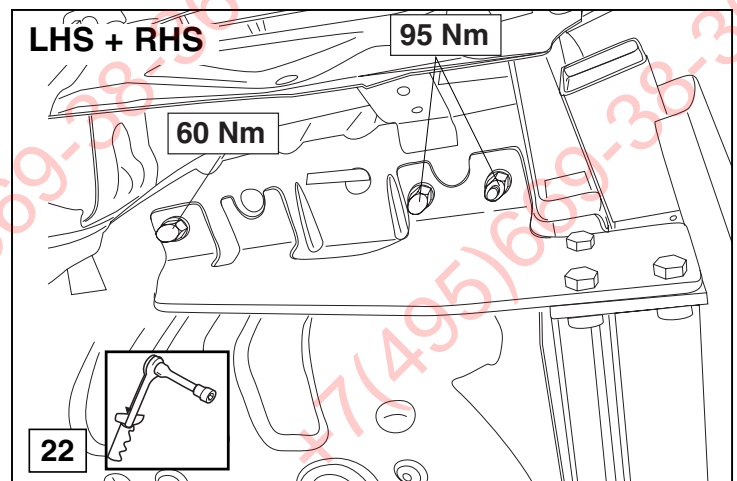
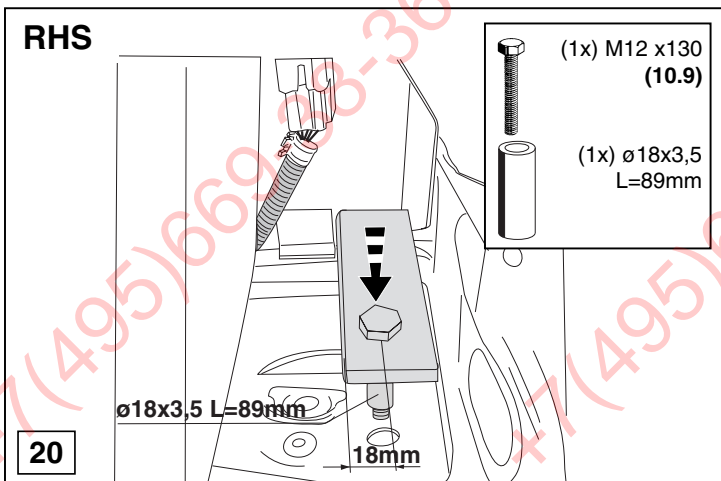
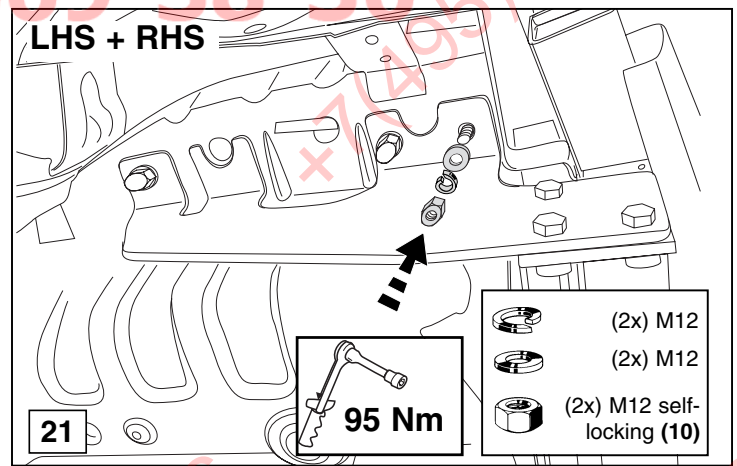
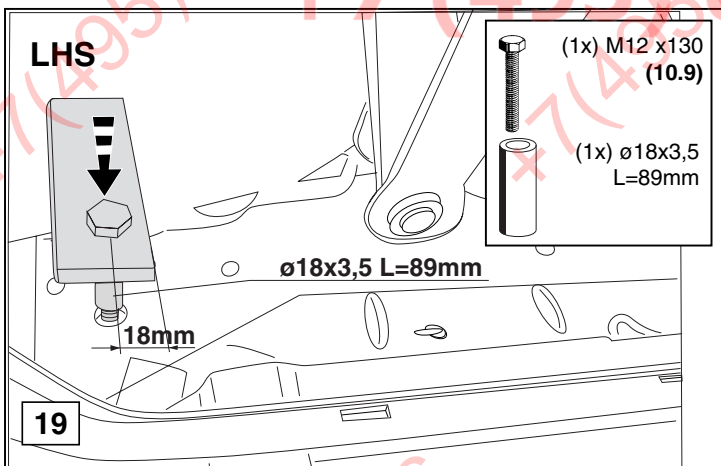

© 409870/04-07-2003/10

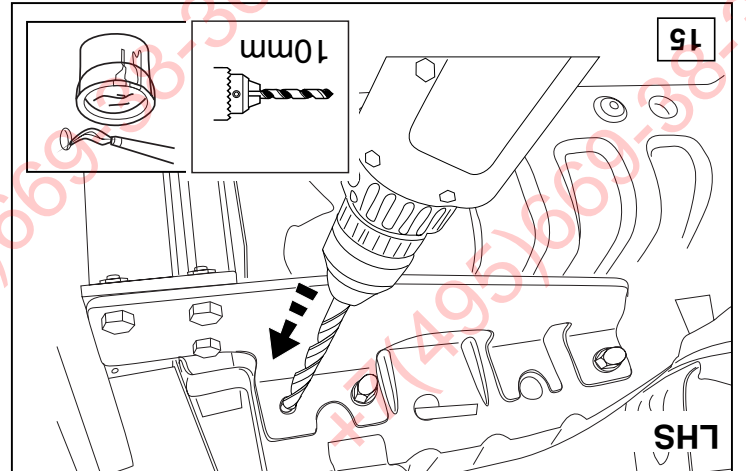
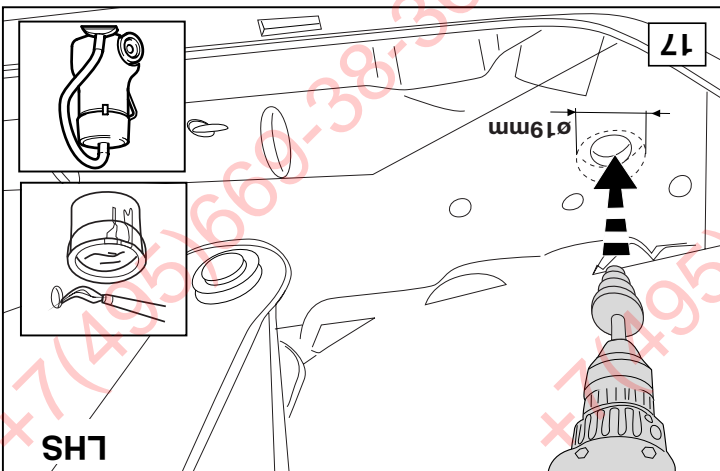
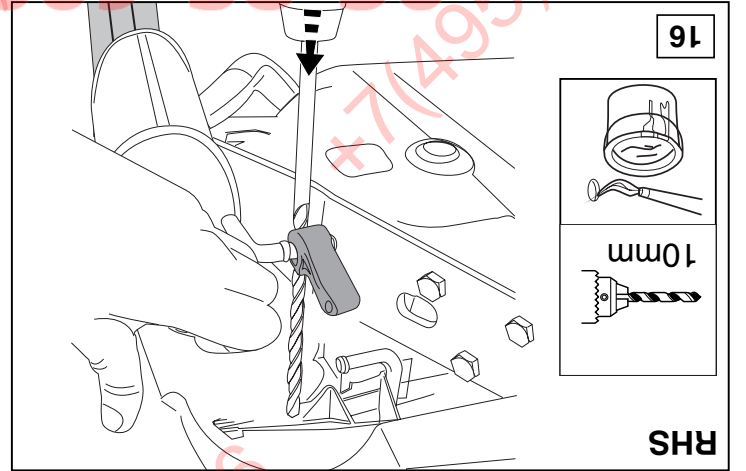
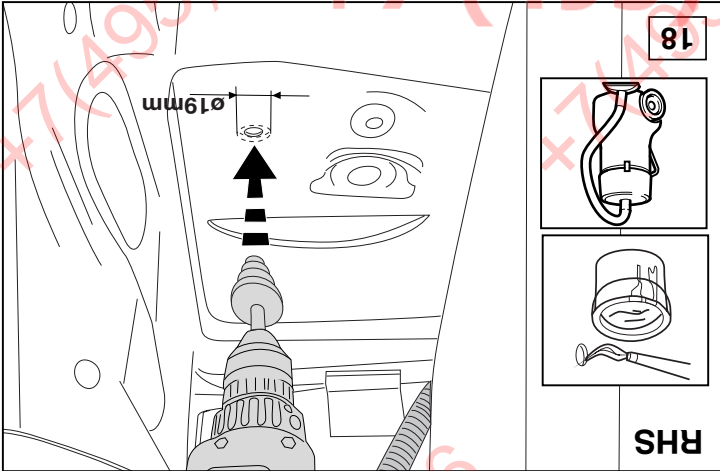
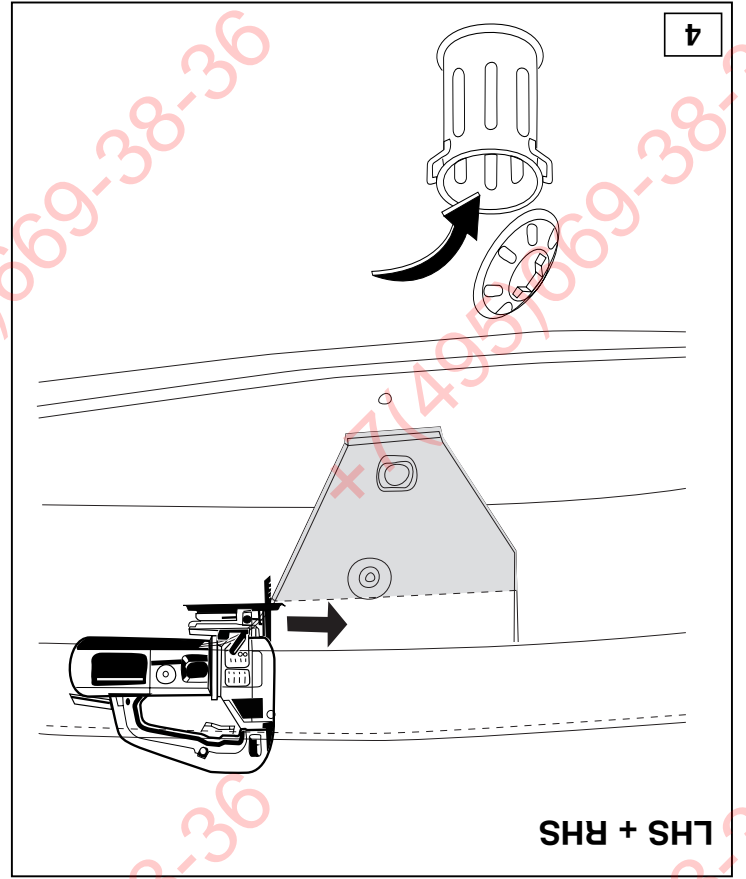
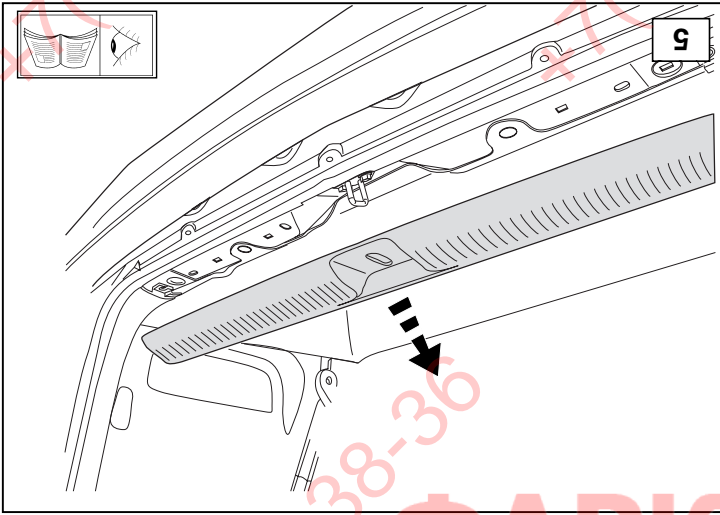
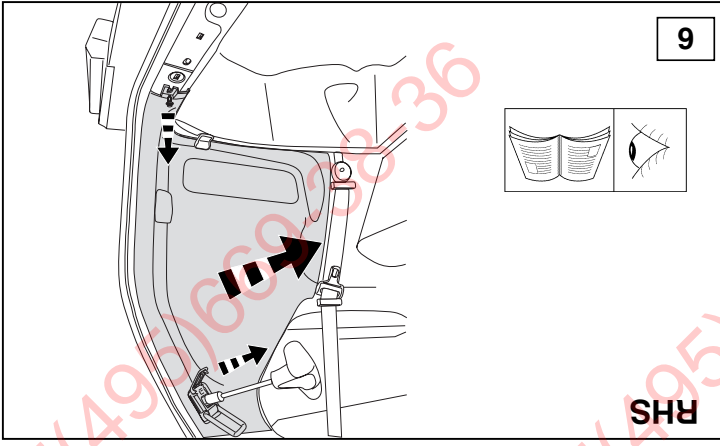

ФАРКОГ.РФ

+7 (495) 669-38-36

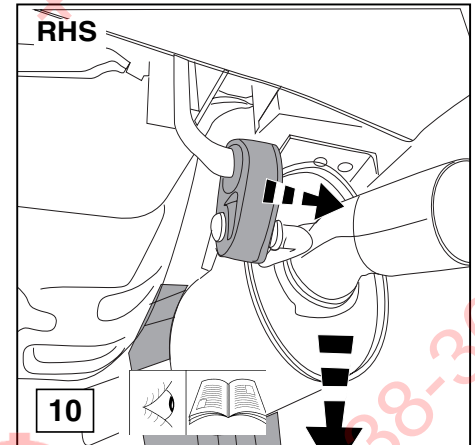
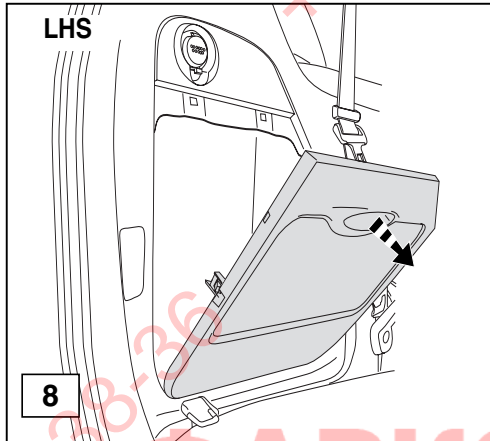
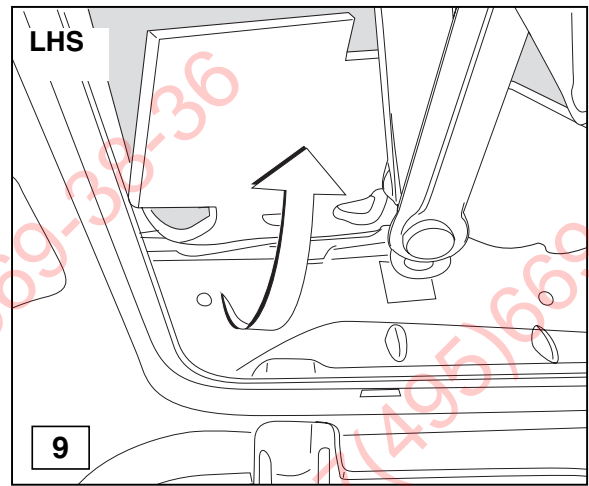
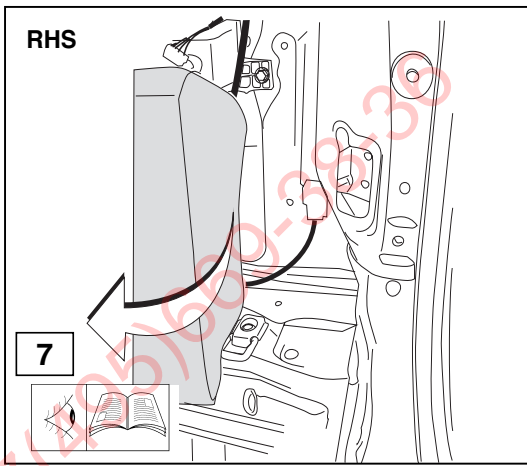

© 409870/04-07-2003/7

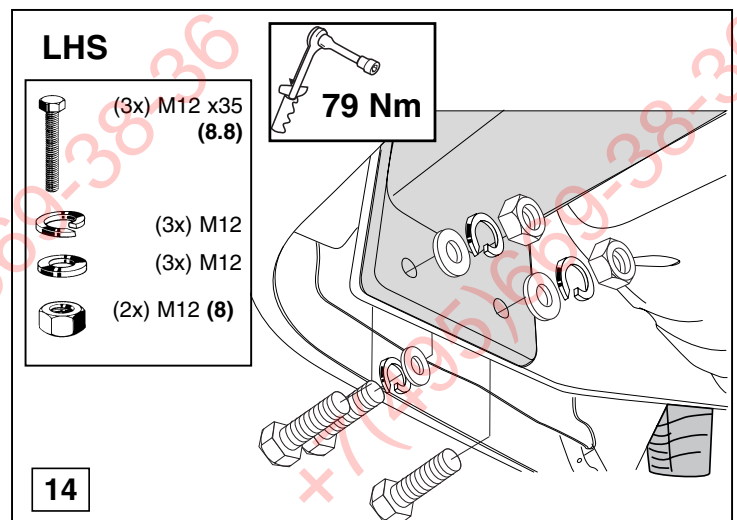
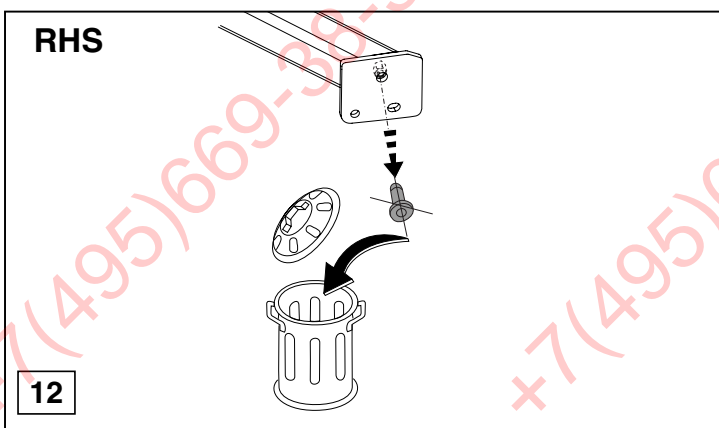
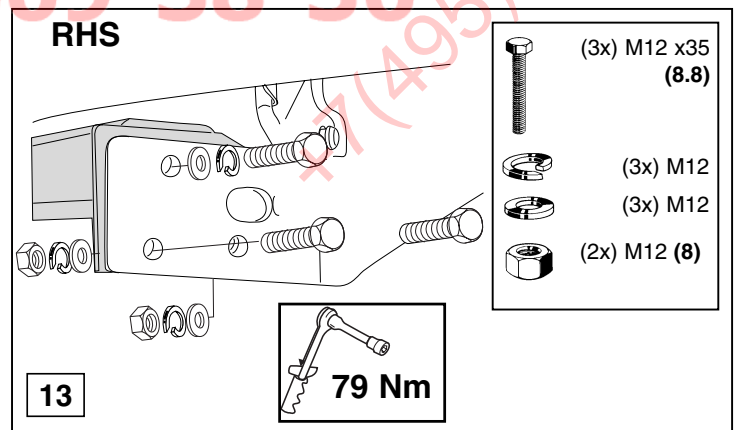
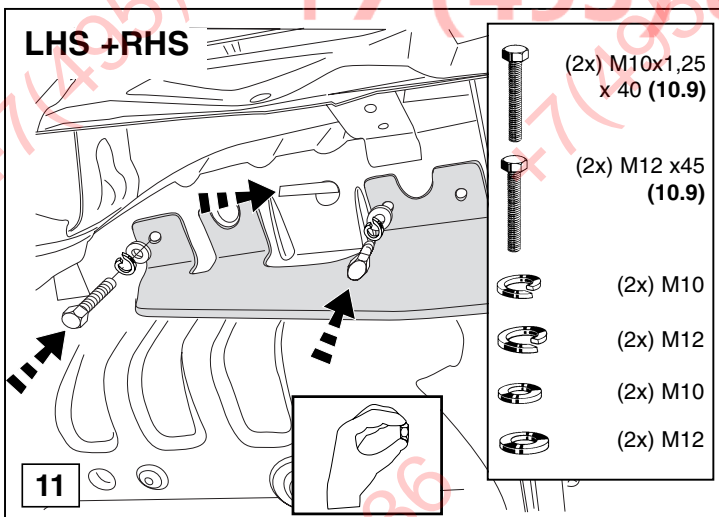

© 409870/04-07-2003/8