

bosal

**Инструкция по монтажу
тягово-цепного устройства
шарового типа 4238 А
для автомобилей
Hyundai Elantra
sedan, НВ**

ФАРКОМ.РФ

+7 (495) 669-38-36

	2000/8-...
	1400
	65
	14.25

.....
..... VIN



462800,

« - »

18
: (35363) 7-05-06
/ : (35363) 7-13-20
(495) 785-66-07

www.bosal-autoflex.ru

« - »	(8182) 22-48-15
"	" 8(8442) 98-74-98
"	" 8(343) 379-39-89, 373-42-73
"	" 8(343) 26-88-308
"	" 8(3952) 710-194
"	" 8(495) 777-54-59
"	" 8(495)745-79-11
"	" 8(495) 788-95-97
"	" 8(495) 720-51-03
"	" 8(3532) 57-99-85
"	" 8-905-899-5012
"	" 8(383) 291-59-60
"	" 8(831) 279-53-24
"	" 8(3422) 98-27-20
"	" 8(342) 220-87-87
"	" 8-927-002-90-06
"	" 8(3462) 24-00-44
"	" 8(3842) 21-14-76
"	" 8-902-940-4151
"	" 8(3452) 32-22-12, 41-52-62
"	" 8-961-213-0278
"	" 8-917-347-1700
"	" 8(351) 269-44-75, 900-72-73
"	" 8(3512) 773-76-91

41.55-2005.

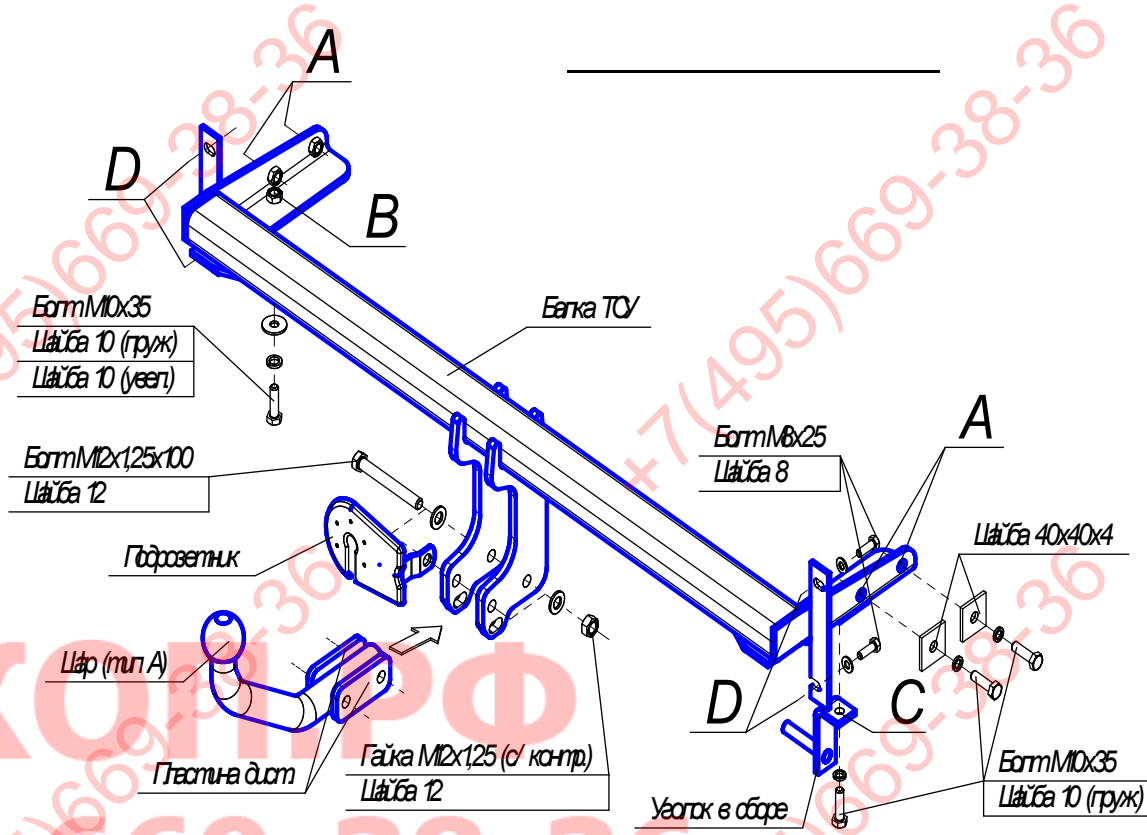

" " " " (10 35).
 () 10 35;
 "D" (8 25);

ФАРКОМФ

+7 (495) 669-38-36

	1
	1
	1

	3
8 25	4
10 35	6
12 1,25 100	2
12 1,25 /	2
8	4
40 40 4	4
10 ()	6
10 ()	1
12	4
	1
	2
VH 0814	1
	1
	1
	1
190	1
	1
	1

1		
2		
3		
4		
5		
6		
7		

