

ORIS
ACPS



© RUN

bosai



Сертификат соответствия
№ TC RU C-RU.AE56.B.00551

Part number: 4532-AX

Without E-set

Без электрики

Mazda CX 5

☒ 2012 →

☒ 2015 →

☒ 2017 →

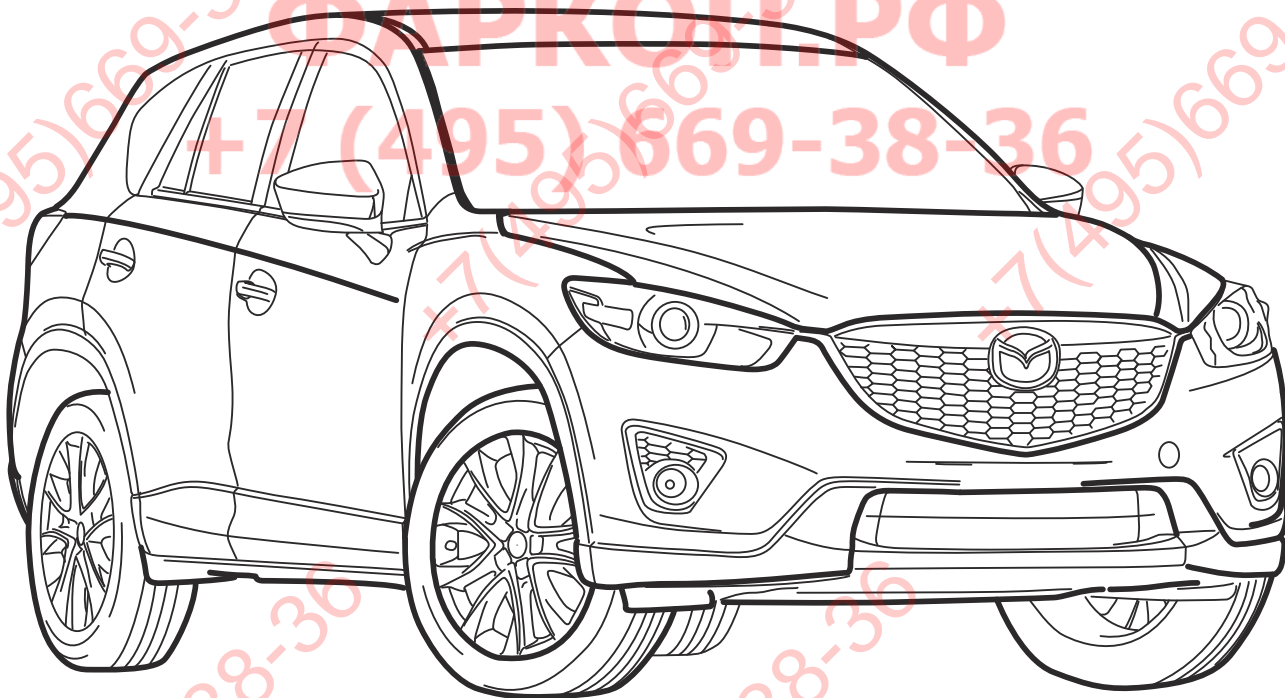

Порядок установки

ООО «Эй-Си-Пи-Эс Автомотив»
462800, Россия, Оренбургская обл.,
п. Новоорск, ул. Шоссейная 18
Тел.: (35363) 7-05-06 / (495) 799-13-46
Тел./ факс: (35363) 7-13-20
www.acps-automotive.ru
www.acps-automotive.com
farkop@acps-automotive.com



D = $\frac{\text{MAX KG} \times \text{MAX KG}}{1000} \times 0,00981 \leq 12,11 \text{ kN}$

MAX KG + MAX KG

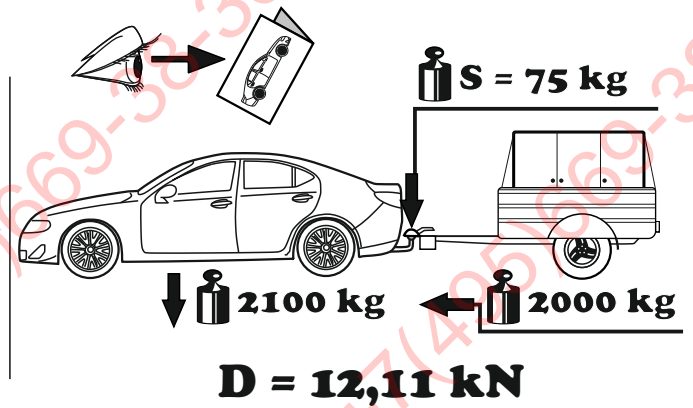

- GB** The clearance specified in appendix VII, diagram 25 of guideline ECE-R 55 must be guaranteed.
- D** Der Freiraum nach Anhang VII, Abbildung 25 der Richtlinie ECE-R 55 ist zu gewährleisten.
- H** Az ECE-R 55 irányelv VII. mellékletében, a 25. ábrán a vonógömb elhelyezése számára előírt szabad tér-adatakat biztosítani kell.
- F** La zone de dégagement doit être garantie conformément à l'annexe VII, illustration 25 de la directive ECE-R 55.
- I** Deve essere garantito lo spazio libero secondo l'allegato VII, figura 25 della direttiva ECE-R 55.
- NL** De tussenruimte conform supplement VII, afbeelding 25 van de richtlijn ECE-R 55 moet in acht worden genomen.
- E** Debe garantizarse el espacio libre, conforme al anexo VII, figura 25 de la directiva comunitaria ECE-R 55.
- FIN** Vapaa tila on taattava direktiivin ECE-R 55 liitteen VII, kuvan 25 mukaisesti.
- S** Spelrummet enligt bilaga VII, figur 25 i riktlinje ECE-R 55 skall garanteras.
- N** Frirommet etter tillegg VII, figur 25 i direktiv ECE-R 55 skal overholdes.
- CZ** Volný prostor ve smyslu Přílohy VII, obr. 25 Směrnice č. ECE-R 55 musí být zaručen.
- PL** Należy zagwarantować wolną wysokość określoną na rysunku nr 25 dyrektywy ECE-R 55 zawartej w załączniku nr VII.
- RU** Необходимо обеспечить данные свободного пространства, предписанные для размещения тягового шарика в приложении VII. директивы ECE-R 55.
- DK** Frirommet skal overholdes iht. bilag VII, fig. 25 i direktiv ECE-R 55.

- GB** at laden weight of the vehicle
- D** bei zulässigem Gesamtgewicht des Fahrzeuges
- H** rakománnyal terhelt járműsúly esetén.
- F** pour poids total en charge autorisé du véhicule
- I** per un peso complessivo ammesso del veicolo
- NL** bij toelaatbaar totaal gewicht van het voertuig
- E** con peso total autorizado del vehículo
- FIN** ajoneuvon suurimmalla sallitulla kokonaispainolla
- S** vid fordonets tillfna totalvikt
- N** ved kjøretøyets tillatte totalvekt
- CZ** při celkové přípustné hmotnosti vozidla
- PL** w przypadku największej dozwolonej masy całkowitej
- RU** В случае нагруженного автомобиля.
- DK** ved tilladt samlet vægt for køretøjet

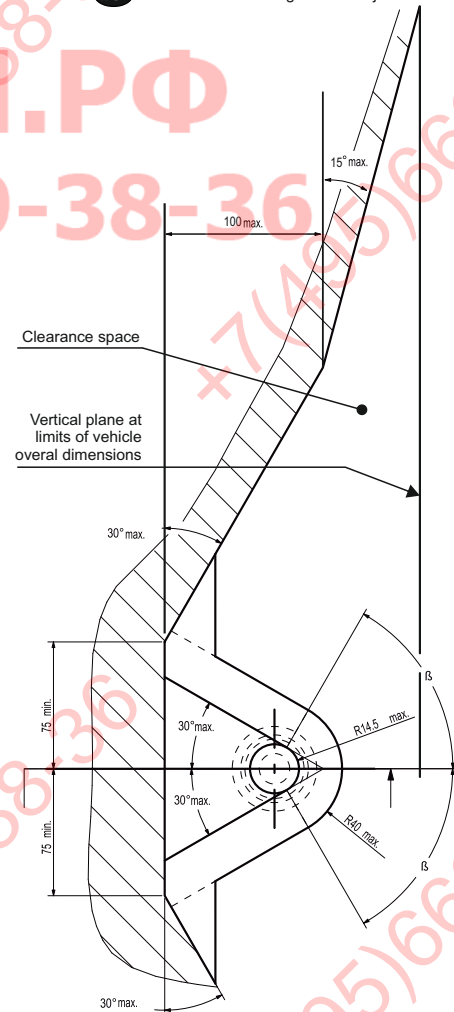
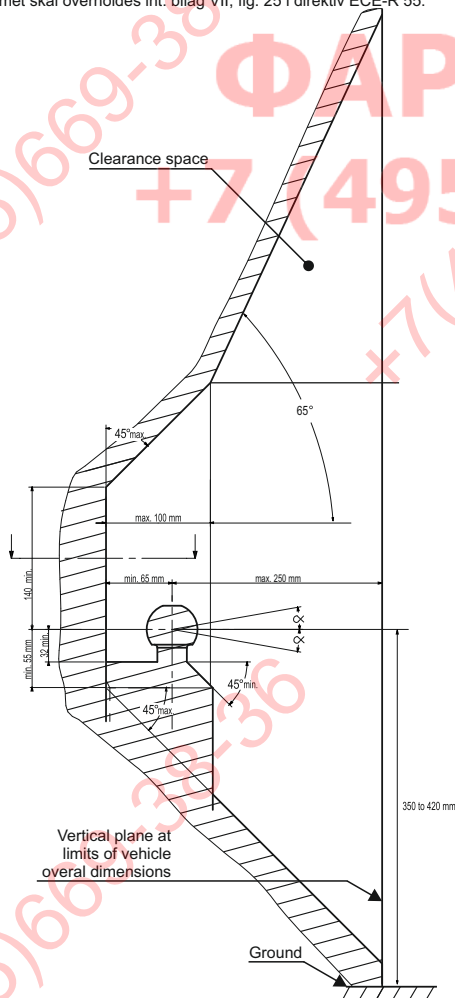



- GB** Attention
- D** Achtung
- H** Figyelem
- F** Attention
- I** Attenzione
- NL** Let op
- E** Atención
- FIN** Huomio
- S** Varning
- N** Pass på
- CZ** Pozor
- PL** Uwaga
- RU** Внимание
- DK** Bemærk



- GB** Incorrect
- D** Falsch
- H** Helytelen
- F** Incorrect
- I** Sbagliato
- NL** Fout
- E** Incorrecto
- FIN** Väärä
- S** Fel
- N** Feil
- CZ** Špatně
- PL** Nieprawidłowo
- RU** Неправильно
- DK** Forkert



- GB** Correct
- D** Richtig
- H** Helyes
- F** Correct
- I** Giusto
- NL** Goed
- E** Correcto
- FIN** Oikea
- S** Rätt
- N** Riktig
- CZ** Správně
- PL** Prawidłowo
- RU** Правильно
- DK** Rigtig



- GB** Inspect
- D** Überprüfen
- H** Vizsgálja meg
- F** Examiner
- I** Esaminare
- NL** Controleren
- E** Revise
- FIN** Tutki
- S** Kontrollera
- N** Undersøk
- CZ** Prohlédnout
- PL** Należy sprawdzić
- RU** Проверьте
- DK** Undersøg



- GB** In both sides
- D** Auf beiden Seiten
- H** Mindkét oldalon
- F** Tous les deux côtés
- I** Su entrambi i lati
- NL** Aan beide kanten
- E** En ambos lados
- FIN** Molempi sivu
- S** På båda sidorna
- N** På begge sider
- CZ** Na obou stranách
- PL** Z obu stron
- RU** На обеих сторонах
- DK** På begge sider



- GB** Manually
- D** Mit manueller Kraft
- H** Kézi erővel
- F** À la main
- I** Con forza manuale
- NL** Met de hand
- E** A mano
- FIN** Kädenvoimalla
- S** Manuellt
- N** Bruk bare håndkraft
- CZ** Ručně
- PL** Ręcznie
- RU** Вручную
- DK** Med manuel kraft



- GB** Only two persons may carry it
- D** Nur zu zweit ausführen
- H** Csak két személy végezheti el
- F** Toujours s'y mettre de deux
- I** Da eseguire soltanto in due
- NL** Alleen met 2 personen uitvoeren
- E** Operación que requiere dos personas
- FIN** Kahden hengen tehtävä
- S** Utförs endast av två personer
- N** Må utføres av to personer
- CZ** Provádět jen ve dvou
- PL** Wykonywać tylko w dwie osoby
- RU** Выполнять только вдвоем
- DK** Skal udføres af to personer



- GB** Remove
- D** Entsorgen
- H** Távolítsa el
- F** Rebuter
- I** Smaltire i rifiuti
- NL** Weggoeien
- E** Tratamiento de residuos
- FIN** Poista
- S** Ta hand om avfallet
- N** Ta hånd om avfallet
- CZ** Vyhodit
- PL** Usunąć jako odpad
- RU** Удалить
- DK** Affald



- GB** Location/Position Arrow
- D** Positionspfeil
- H** Helyzetjelző nyíl
- F** Flèche de Position
- I** Freccia di posizione
- NL** Lokatie-/positiepil
- E** Flecha de posición
- FIN** Asentonuoli
- S** Positionpil
- N** Posisjonspil
- CZ** Šipka na pozici
- PL** Strzałka położenia
- RU** Стрелка положения
- DK** Lokaliseringspil



- GB** Movement Arrow
- D** Bewegungspfeil
- H** Mozgásirányjelző nyíl
- F** Flèche de mouvement
- I** Freccia di movimento
- NL** Richtingspil
- E** Flecha de movimiento
- FIN** Liikesuuntanuoli
- S** Rörelsepil
- N** Bevegelsespil
- CZ** Šipka pohybu
- PL** Strzałka kierunku ruchu
- RU** Стрелка хода
- DK** Bevægelsespil



- GB** Electrical connection
- D** Elektroanschluss
- H** Elektromos csatlakozás
- F** Connexion électrique
- I** Collegamento elettrico
- NL** Elektrische aansluiting
- E** Conexión eléctrica
- FIN** Sähköliitäntä
- S** Elektrisk anslutning
- N** Elektrisk kontakt
- CZ** Elektrické připojení
- PL** Podłączenie do prądu
- RU** Электрическое соединение
- DK** Elektrisk forbindelse



- GB** Protect it against corrosion
- D** Gegen Korrosion schützen
- H** Védje korrózió ellen
- F** Protéger contre la corrosion
- I** Proteggere dalla corrosione
- NL** Beschermen tegen corrosie
- E** Proteger contra la corrosión
- FIN** Suoja ruostumisesta
- S** Skydda mot korrosion
- N** Beskytt mot korrosjon
- CZ** Chránit proti korozi
- PL** Chronić przed korozją
- RU** Защищать от коррозии
- DK** Elektrisk forbindelse



- GB** Tools Required
- D** Benötigte Werkzeuge
- H** Szükséges szerszámok
- F** Outils requis
- I** Strumenti necessari
- NL** Benodigd gereedschap
- E** Herramientas requeridas
- FIN** Tarvittavat työkalut
- S** Nödvändiga verktyg
- N** Nødvendige verktøy
- CZ** Potřebné nástroje
- PL** Potrzebne narzędzia
- RU** Необходимые инструменты
- DK** Nødvendige værktøjer

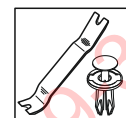
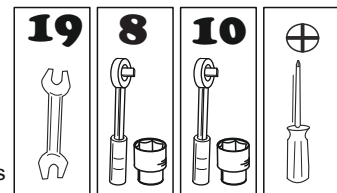

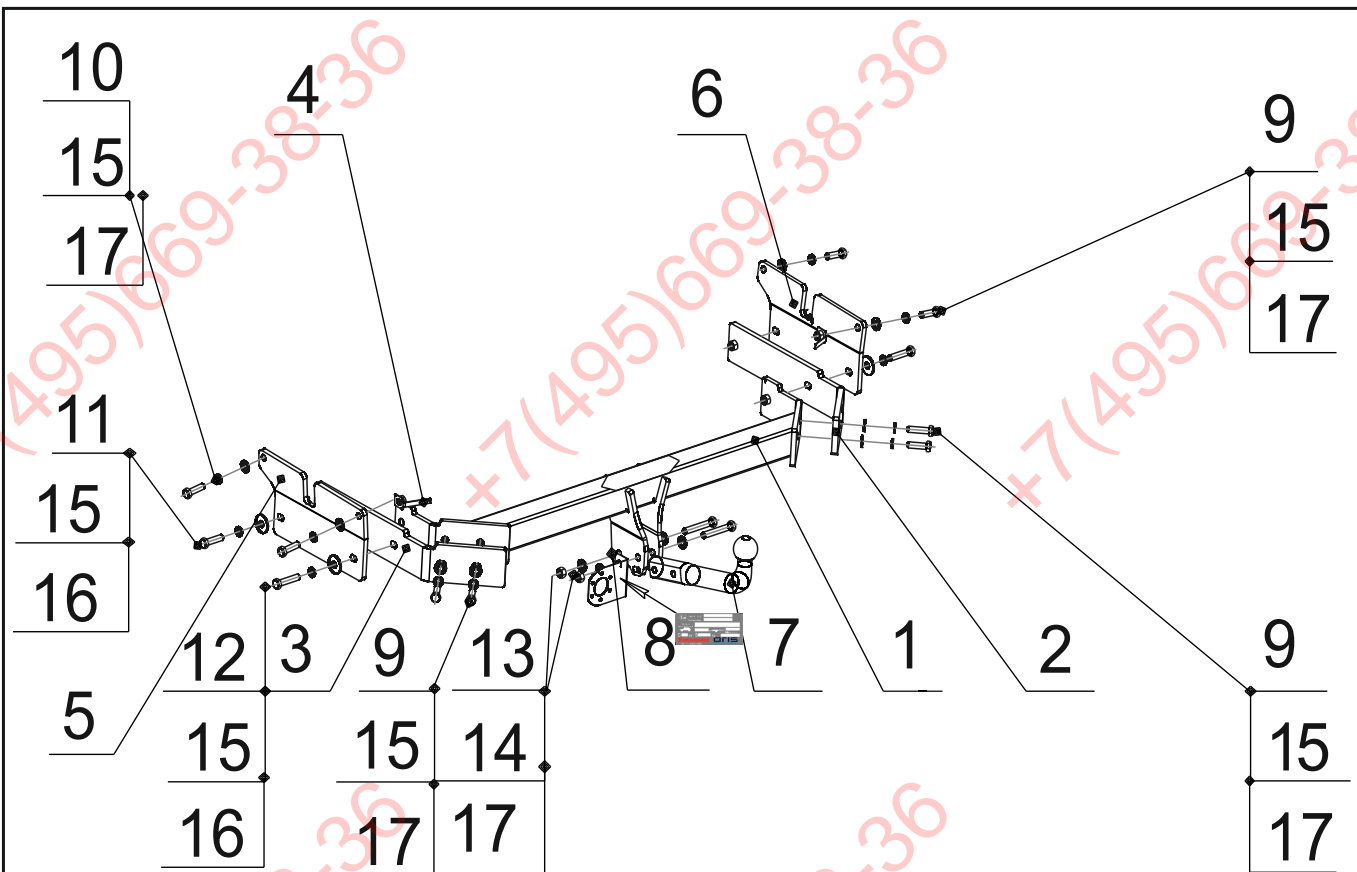

1		4532.01.00.00.00	1x
2		4532.02.00.00.00	1x
3		4532.03.00.00.00	1x
5		4532 0 .01-01	1x
6		4532 0 .01	1x
7		VH8901	1x
8			1x
		022104	1x
			1x

4		4532.04.00.00.00	8.8	2x	79Nm
9		M12x40	8.8	4x	79 Nm
10		M12x1,25x40	8.8	2x	79 Nm
11		M12x45	8.8	4x	79 Nm
12		M12x60	8.8	2x	79 Nm
13		M12x1,25x75	8.8	2x	79 Nm
14		M12x1,25 (с/контр.)	8	2x	79 Nm
15		C12 (пружин.)		2x	
16		C12 (увелич.)		4x	
17		C12		10x	

Nm

C

2 h

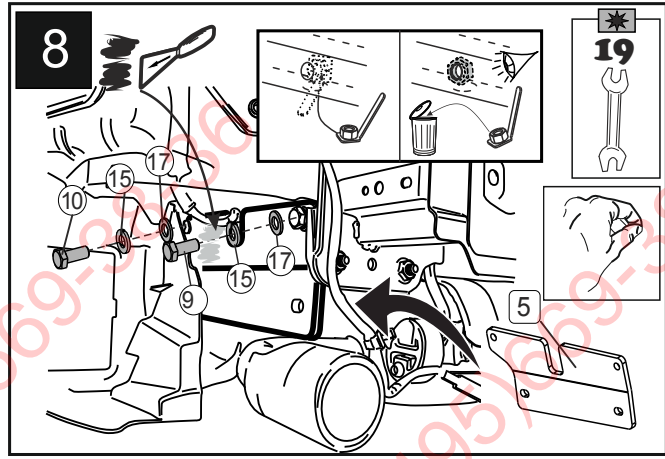
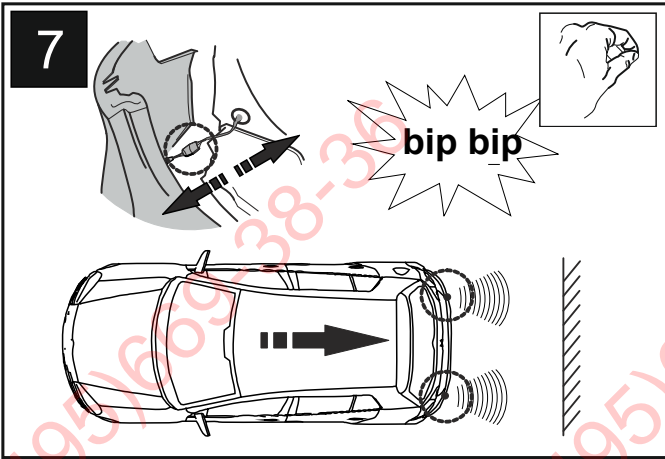
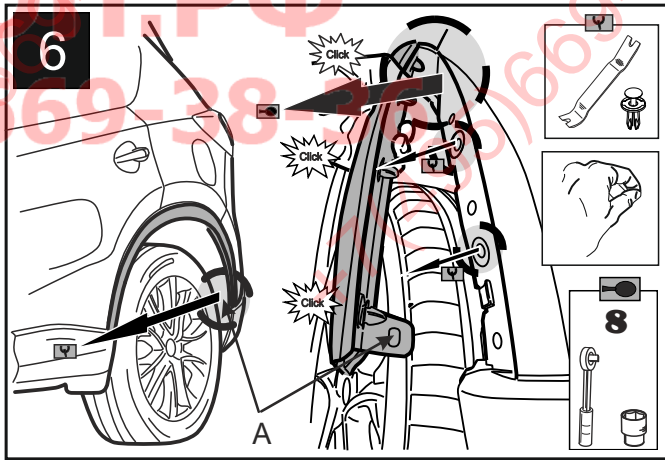
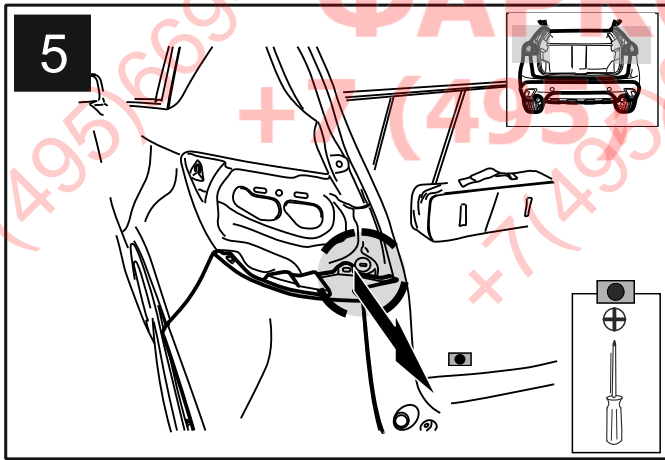
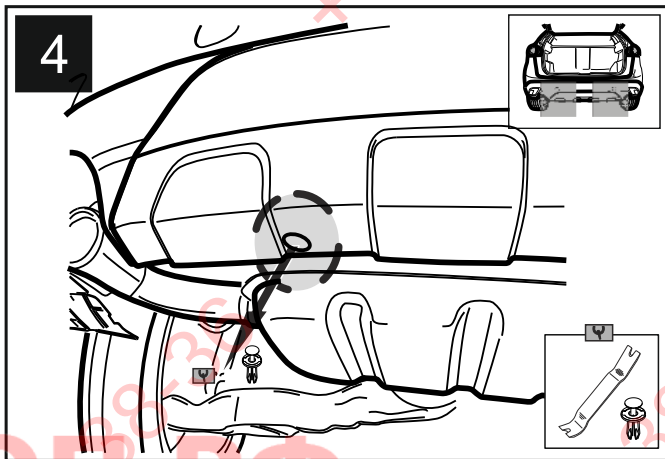
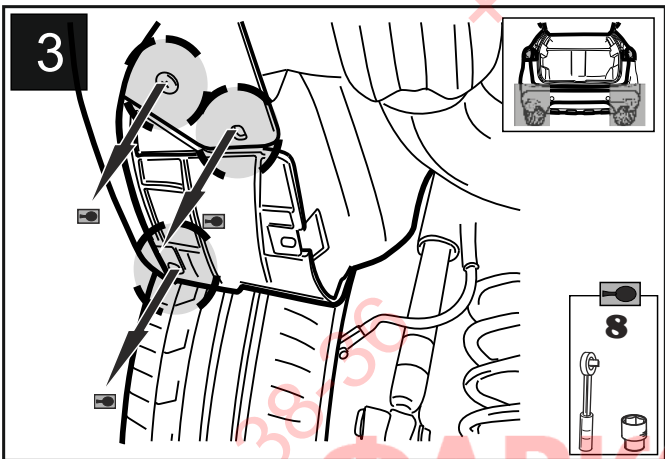
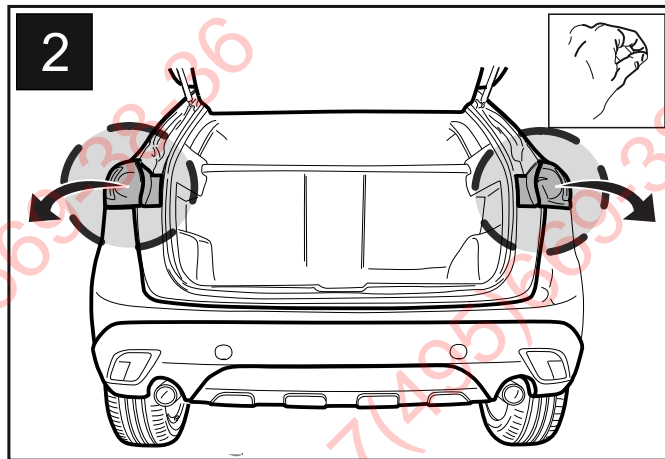
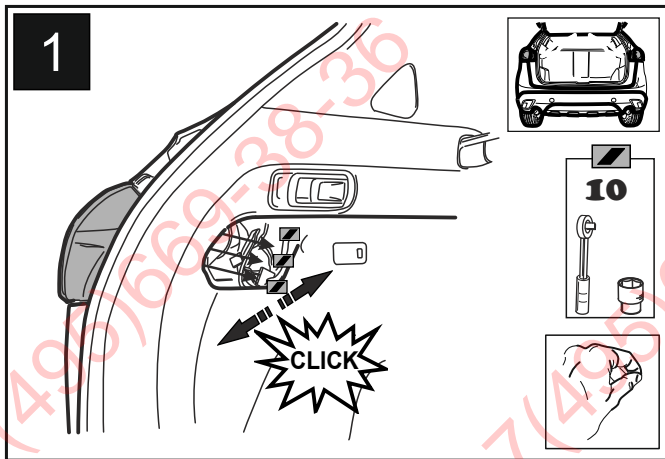

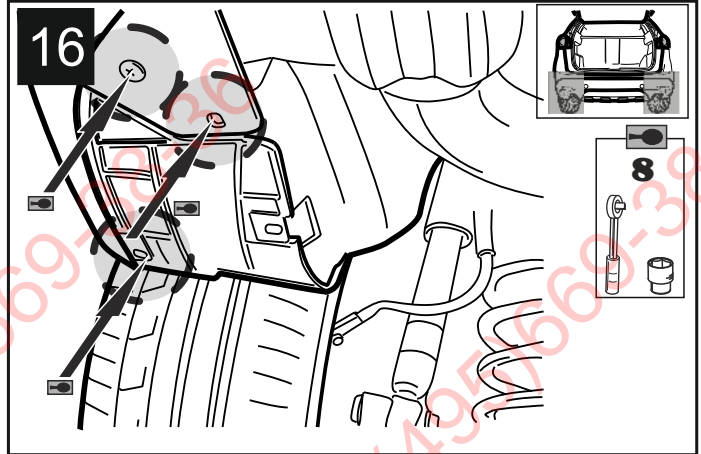
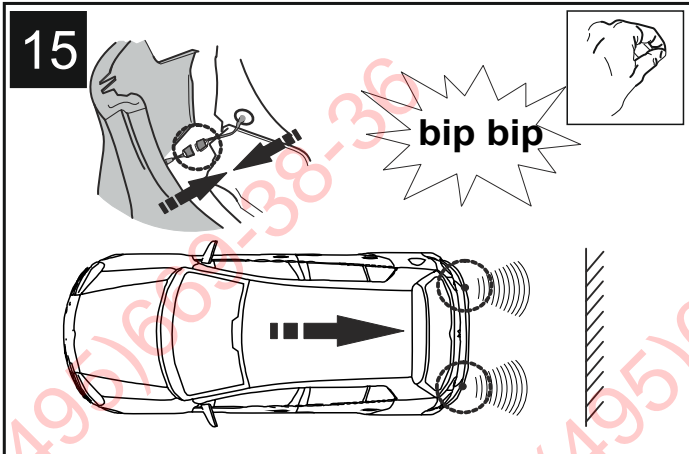
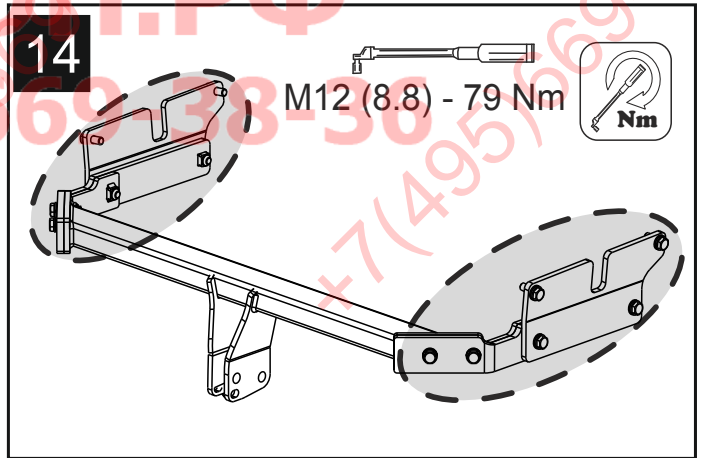
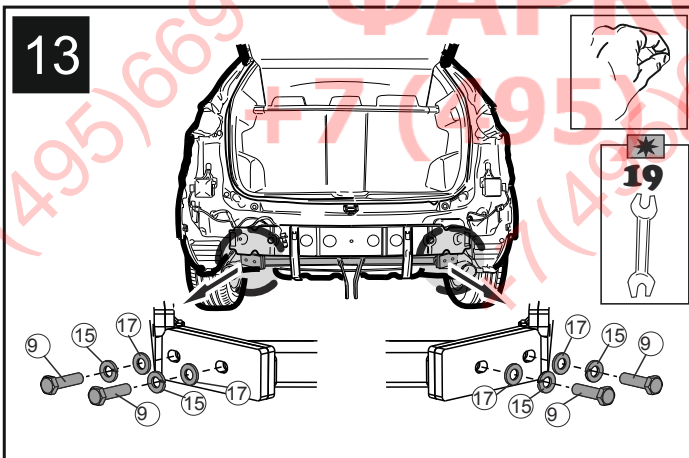
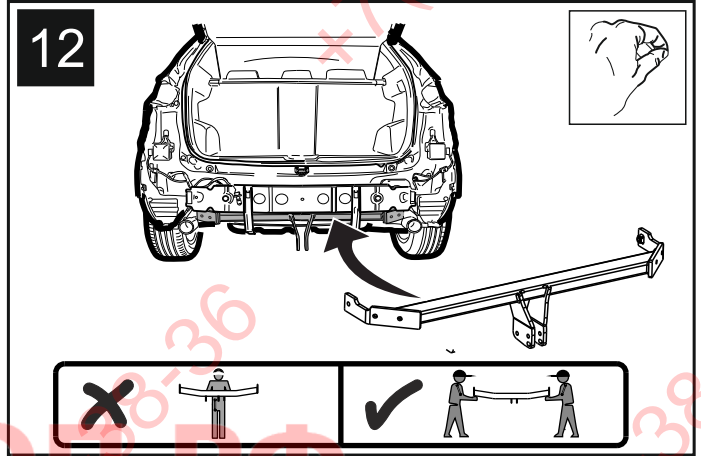
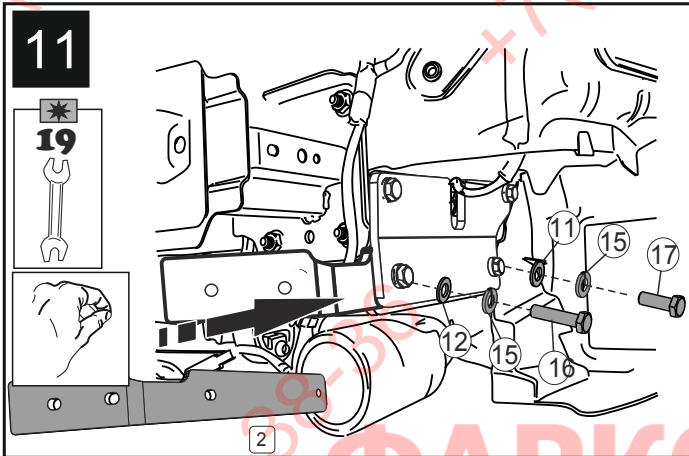
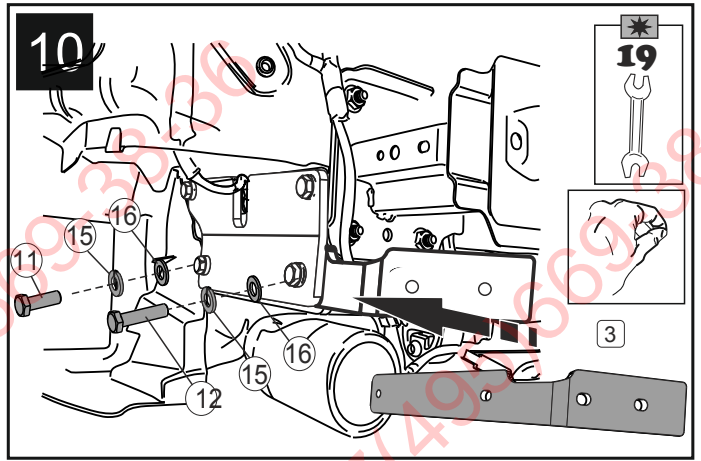
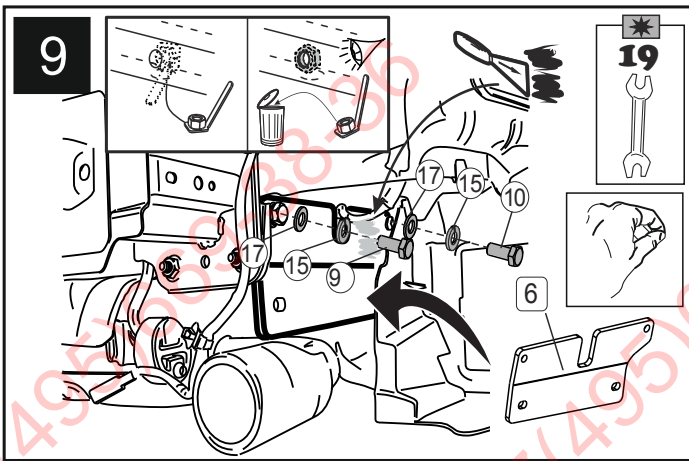

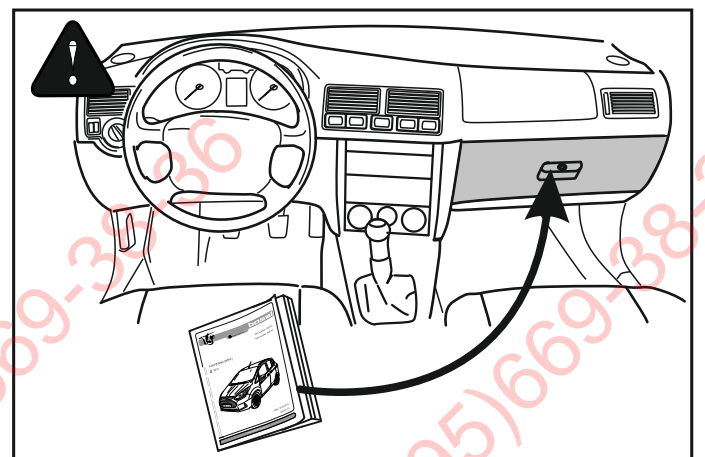
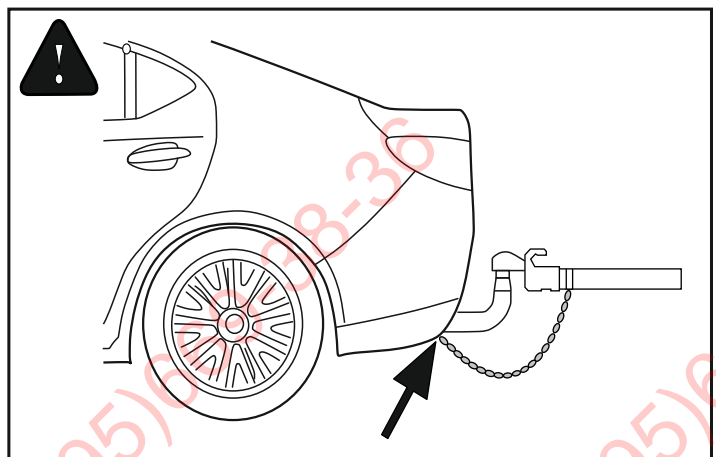
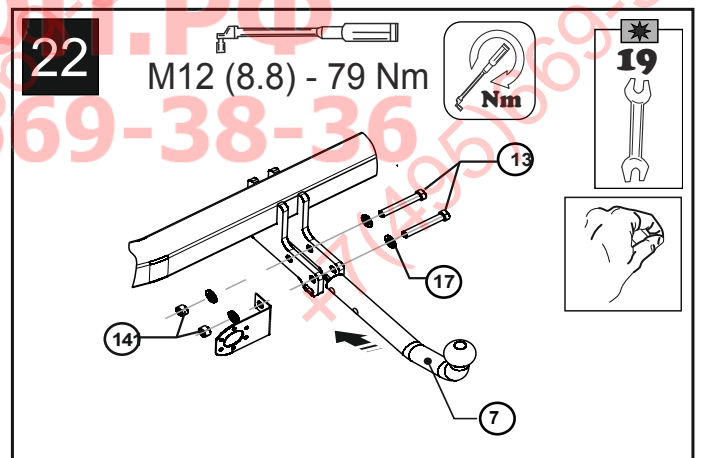
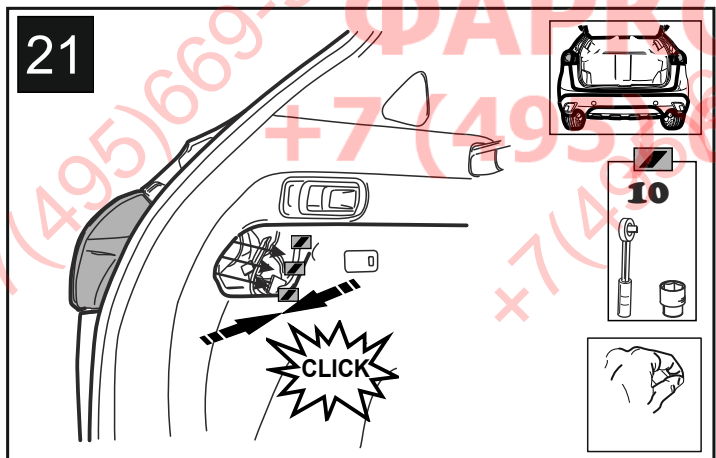
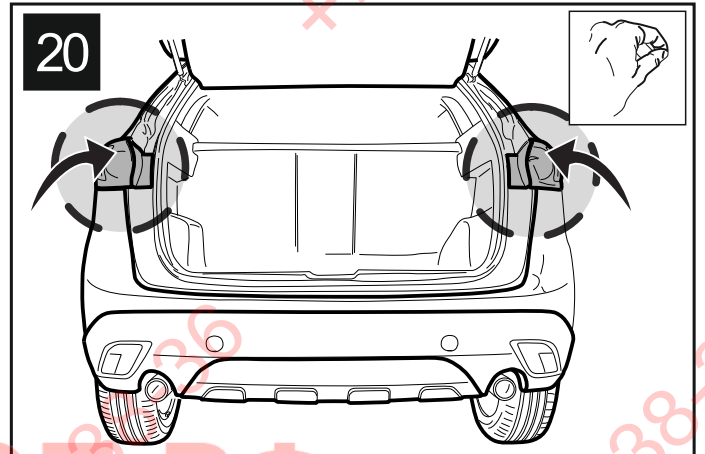
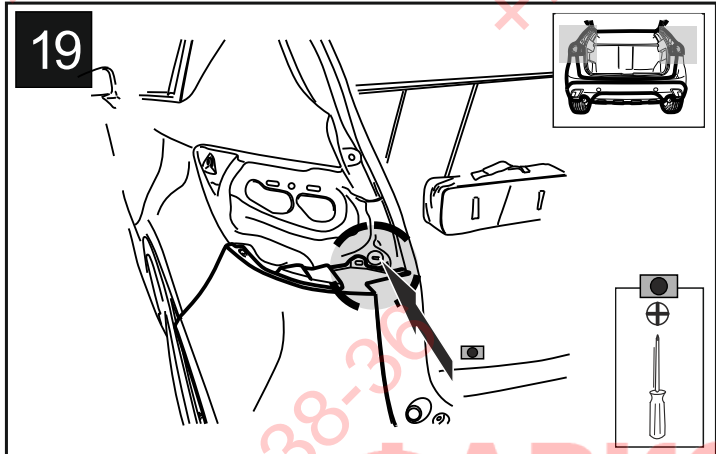
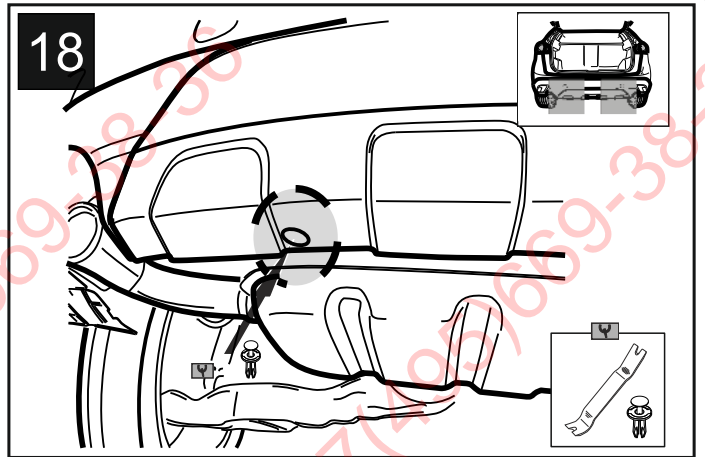
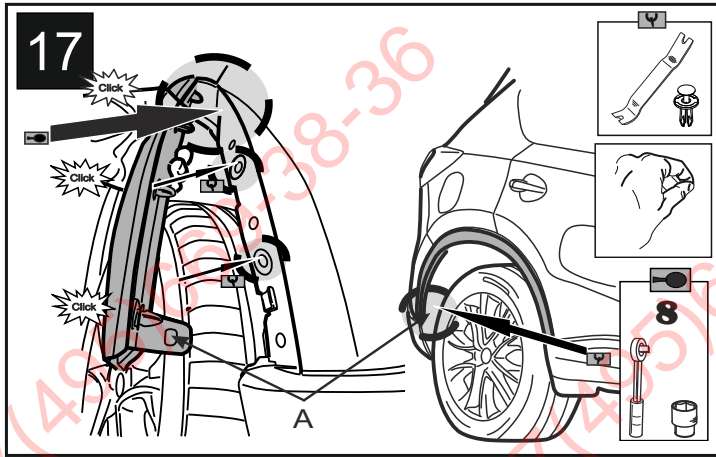

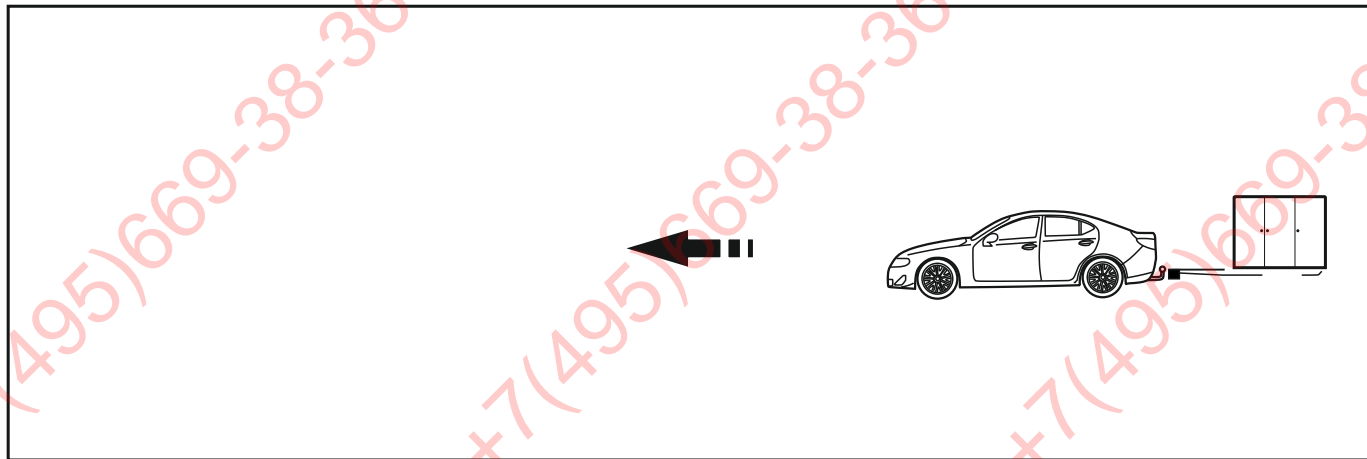

ФАРКОЛ.РФ
+7 (495) 669-38-36