

# bosal

**Инструкция по монтажу  
тягово-цепного устройства  
шарового типа 6405 А  
для автомобилей  
Ssang Yong Rexton**

# ФАРКОП.РФ

# +7 (495) 669-38-36

	2003-...
	1500
	75
	18.0

.....  
..... VIN .....



462800,

« - »

18

∴ (35363) 7-05-06

/ ∴ (35363) 7-13-20

(495) 785-66-07

[www.bosal-autoflex.ru](http://www.bosal-autoflex.ru)

« - »	" (8182) 22-48-15
"	" 8(8442) 98-74-98
"	" 8(343) 379-39-89, 373-42-73
"	" 8(343) 26-88-308
"	" 8(3952) 710-194
"	" 8(495) 777-54-59
"	" 8(495)745-79-11
"	" 8(495) 788-95-97
"	" 8(495) 720-51-03
"	" 8(3532) 57-99-85
"	" 8-905-899-5012
"	" 8(383) 291-59-60
"	" 8(831) 279-53-24
"	" 8(3422) 98-27-20
"	" 8(342) 220-87-87
"	" 8-927-002-90-06
"	" 8(3462) 24-00-44
"	" 8(3842) 21-14-76
"	" 8-902-940-4151
"	" 8(3452) 32-22-12, 41-52-62
"	" 8-961-213-0278
"	" 8-917-347-1700
"	" 8(351) 269-44-75, 900-72-73
"	" 8(3512) 773-76-91

41.55-2005.

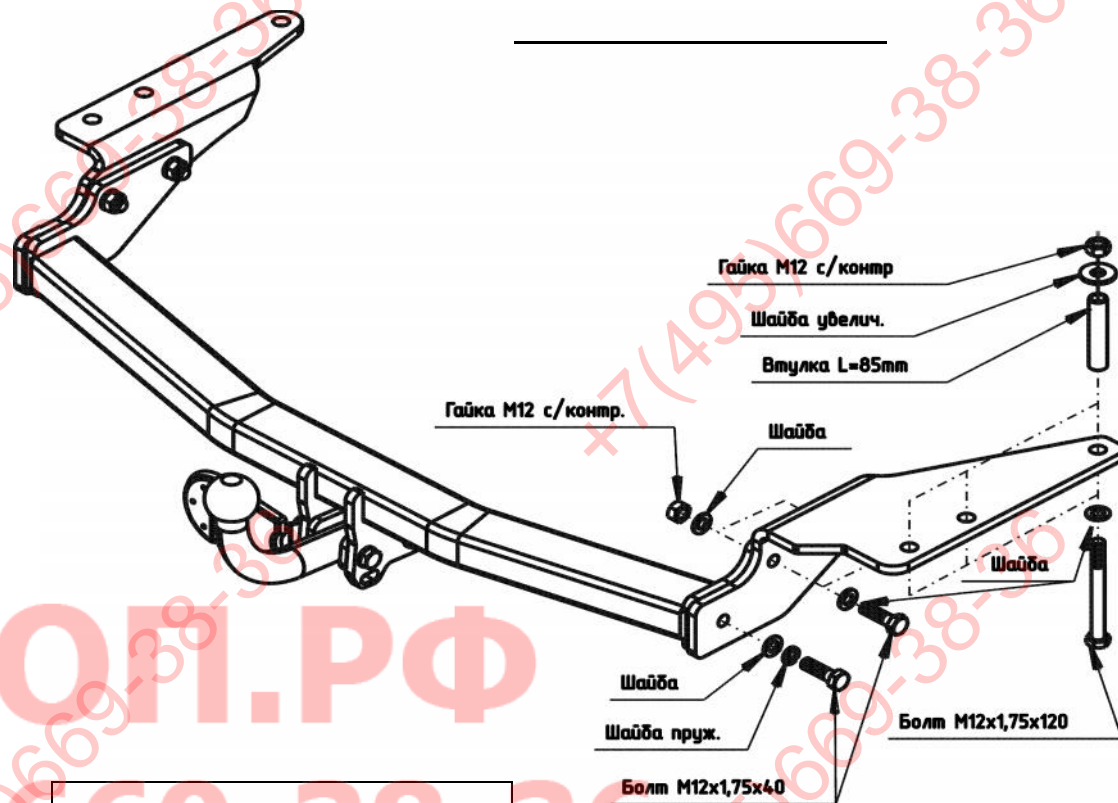

( )  
18 ( )

(L=85mm).

M12x40

M12x120.

M12x90.

ФАРКОП.РФ

+7 (495) 669-38-36

	1
	1
	1
	1
	1

	3
12 1,25 90	2
12 120	6
12 40	6
12 1,25 /	2
12 /	10
12 65 ( )	2
12	19
12	6
L - 85	6
	2
VH 0137	1
	1
	1
	1
190	1
	1

1			
2			
3			
4			
5			
6			
7			

