



**FORD FOCUS I estate**  
(excl. RS bumper)

02/99-01/05

Cat. No. **E/025**

e20

e20\*94/20\*1698\*00

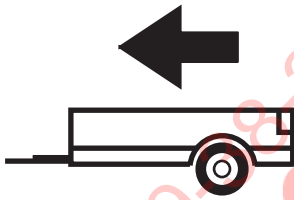

1400kg



75kg

**D = 7,40kN**

**D (kN) =**



MAX kg

x

MAX kg

x 0,00981



MAX kg

+

MAX kg

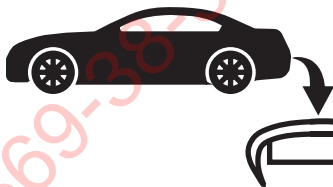

IMIOLA HAK-POL

96-111 KOWIESY, CHOJNATA 23A, POLAND

Tel. + 48 46 831 73 31, fax +48 831 74 29

e-mail: office@imiola.pl, www.imiola.pl

## PRZEKRÓJ A-A

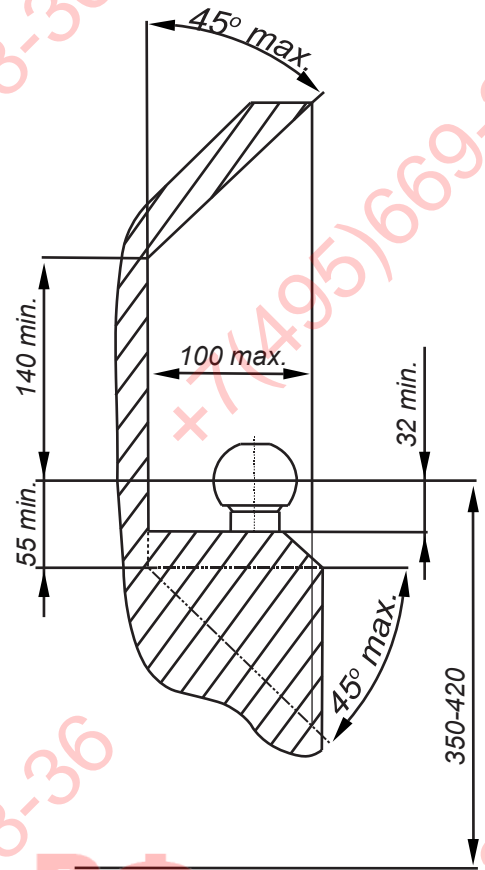
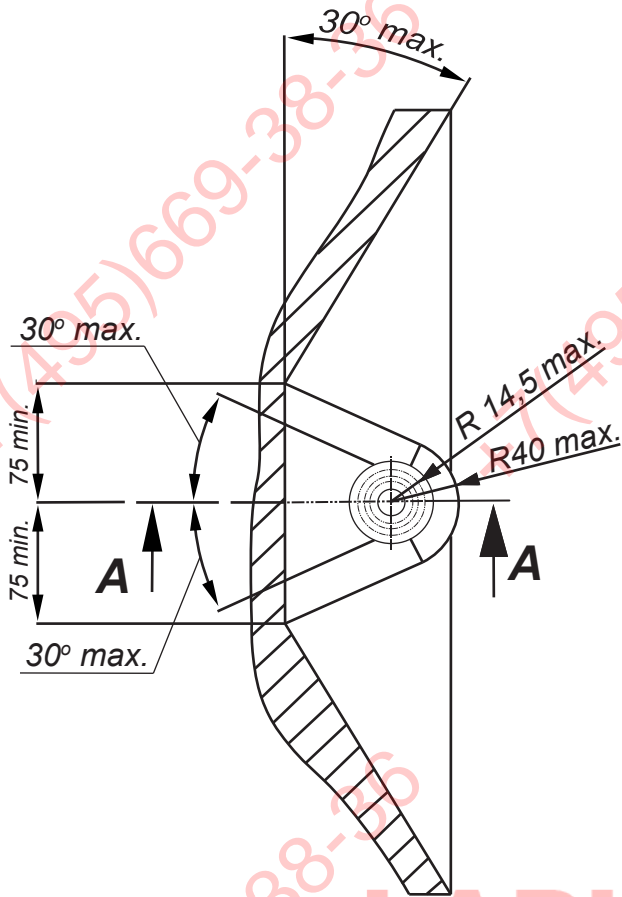

**PL** Należy zagwarantować przestrzeń swobodną według załącznika VII, rysunek 25a/b Regulaminu EKG ONZ 55.01 przy dopuszczalnym ciężarze całkowitym pojazdu.

**F** L'espace libre doit être garanti conformément à l'annexe VII, illustration de la réglementation 55.01 CE pour un poids total en charge autorisé du véhicule.

**GB** The clearance specified in appendix VII, diagram 25a/b of Regulation No. 55.01 UN EU must be guaranteed at laden weight of the vehicle.

**D** Der Freiraum nach Anhang VII, Abbildung 25a/b der Vorschriften 55.01 EG ist zu gew 25a/b abzuhalten bei zulässigem Gesamtgewicht des Fahrzeuges.

Moment skręcający dla śrub i nakrętek (8.8) Torque settings for nuts and bolts (8.8)	
M8	25Nm
M10	55Nm
M12	85Nm
M14	135Nm
M16	195Nm



Nakrętka M12; Nut  
 Podkl. spręż. 12,2; Spring Washer  
 Podkl. okr. 13; Plain Washer

Śruba M10x35-8.8; Bolt  
 Podkl. spręż. 10,2; Spring Washer  
 Podkl. okr. Ø56x Ø10,5x 3; Plain Washer

Śruba M12x40-8.8; Bolt  
 Podkl. spręż. 12,2; Spring Washer  
 Podkl. okr. 13; Plain Washer



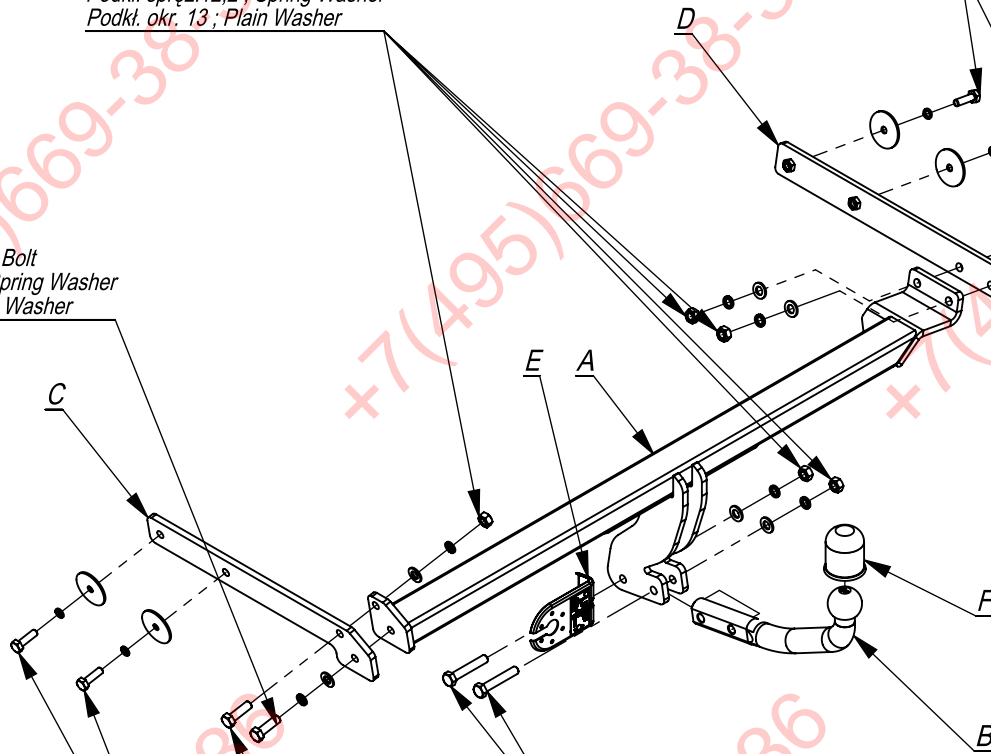





Śruba M12x40-8.8; Bolt

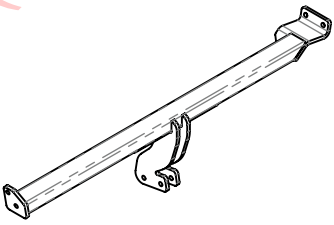
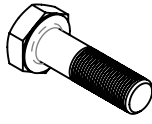
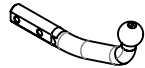

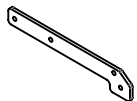
Śruba M12x40-8.8; Bolt

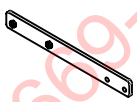
Śruba M12x70-8.8; Bolt

Śruba M10x35-8.8; Bolt  
 Podkl. spręż. 10,2; Spring Washer  
 Podkl. okr. Ø56x Ø10,5x 3; Plain Washer

	A	x1		M12x70	2
				M12x40	4
				M10x35	4
	B	x1		M12	5
					4
	C	x1		13	6
					4
	D	x1		13	6
				10,5	4
	E	x1		13	6
				10,5	4
	F	x1			

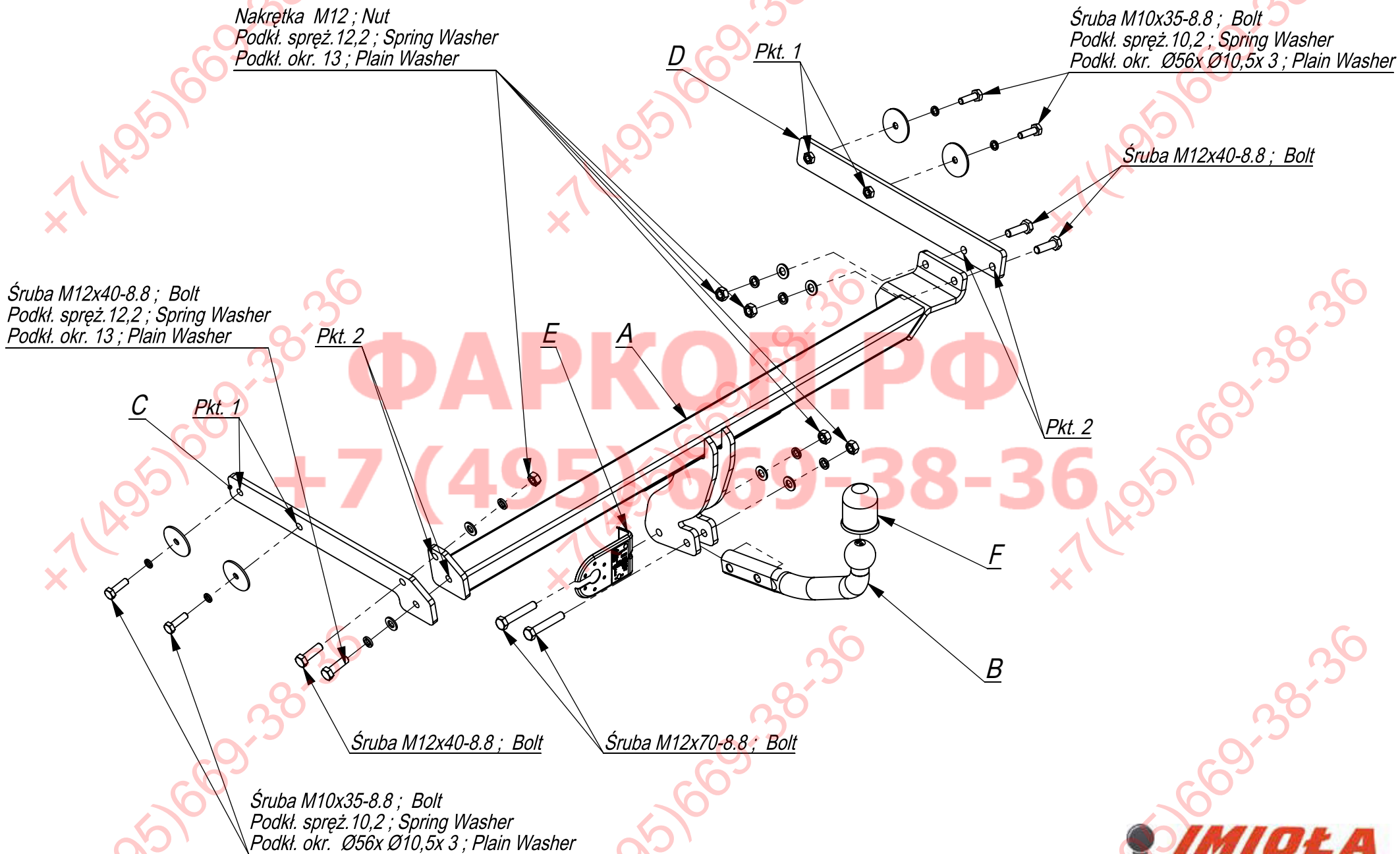

Nr katalogowy  
E/025

Marka  
Ford Focus combi

od 98 ->



96-111 Kowiesy, Chojnata 23 A  
tel. +48 46 831 73 31

- Zdemontować zderzak. Udzielić technologiczne otwory montażu zaczepu znajdujące się na zewnętrznych bokach podłużnic (pkt 1).
- Włożyć w podłużnice wsporniki zaczepu (wspornik C do lewej podłużnicy, wspornik D do prawej) i luźno przykręcić śrubami M10x35 8.8 (pkt 1) stosując podkładki F.
- Do wsporników C i D przykręcić lekko belkę zaczepu A śrubami M12x40 8.8 (pkt 2).
- W wypełnieniu zderzaka wyciąć fragment wg rys.
- Podłączyć instalację elektryczną.
- Wszystkie śruby dokręcić z momentem wg tabeli.
- Zamontować zderzak.
- Przykręcić kulę i blachę gniazda elektrycznego śrubami M12x70 8.8.

- Disassemble the bumper. The technological tow bar tting holes on the external sides of the metal clamps make permeable (point 1).
- Insert the supporters in the metal clamps (the supporter C in the left metal clamp, D in the right) and screw slightly with bolts M10x35 8.8 (point 1) using washers F.
- Screw slightly the main bar A to the supporters C and D with bolts M12x40 8.8 (point 2).
- Cut out the fragment in the lling of the bumper, according to the drawing.
- Connect the electric wires.
- Tighten all the bolts according to the torque setting- see the table.
- Assemble the bumper.
- Fix the ball and electric plate with bolts M12x70 8.8

- Déposer le pare-chocs. Déboucher les ouvertures de crochet situées en externe des longerons (point 1).
- Insérer les consoles d'attache dans les longerons (la console C au longeron gauche, console D à celui de droit) et serrer légèrement avec les boulons M10x35 8.8 (point 1) et plaquettes F.
- Visser légèrement la traverse d'attache A aux consoles C et D par les boulons M12x35 8.8 (point 2).
- Serrer la traverse de crochet A à la partie arrière à travers les ouvertures en utilisant les éléments E selon croquis (point 3 et 4).
- Entreouvrir la pièce dans le garnissage de pare-chocs.
- Raccorder le circuit électrique.
- Serrer tous les boulons avec un couple de serrage selon tableau.
- Poser le pare-chocs.
- Visser la boule et tôle de la prise électrique par les boulons M12x70 8.8.

- Die Stoßstange demontieren. Die vom Werk aus vorhandenen auf den Außenseiten der Längsträger Öffnungen durchlässig machen.
- In die Längsträger, die Stützen (Stütze C in den linken Längsträger, die Stütze D in den rechten Längsträger) stecken und mit den Schrauben M10x35 8.8 (Punkt 1) mit der Anwendung von den Unterlegscheiben F locker anschrauben.
- An die Stützen C und D den Querbalken A mit den Schrauben M12x40 8.8 (Punkt2) locker anschrauben.
- In der Stoßstangeschürze, ein Teil nach der Zeichnung ausschneiden
- Die Elektroinstallation anschließen.
- Alle Schrauben mit dem in der Tabelle angegebenen Drehmoment festziehen.
- Die Stoßstange einbauen.
- Die Kugel mit den Schrauben M12x70 8.8 anschrauben.

- Desenrosque el parachoques
- Abrir agujeros en la parte trasera de los largueros.
- Fijar los elementos C y D del gancho a los largueros con tornillos M10x35, 8.8 (punto 1).
- Atornillar la viga de la bola de remolque A a los elementos C y D usando tornillos M12x40 8.8 (punto 2).
- Hacer una muesca según dibujo 1
- Apretar todos los tornillos con el par según la tabla anterior.
- Instalar el parachoques
- Apretar la bola y la placa de la toma eléctrica

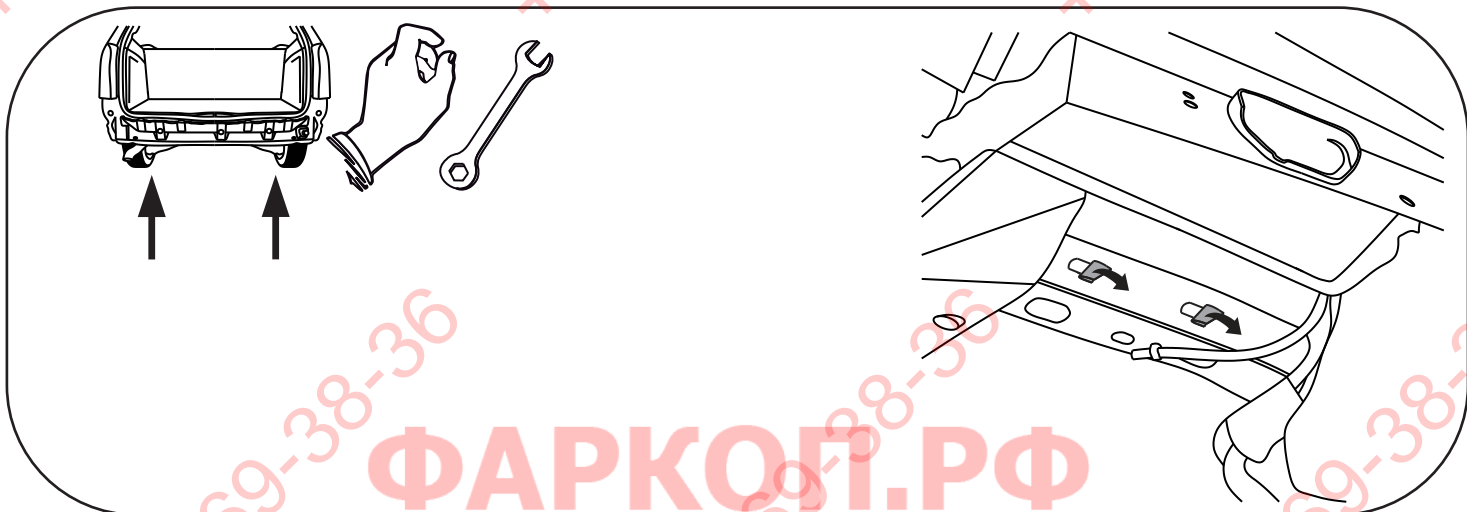
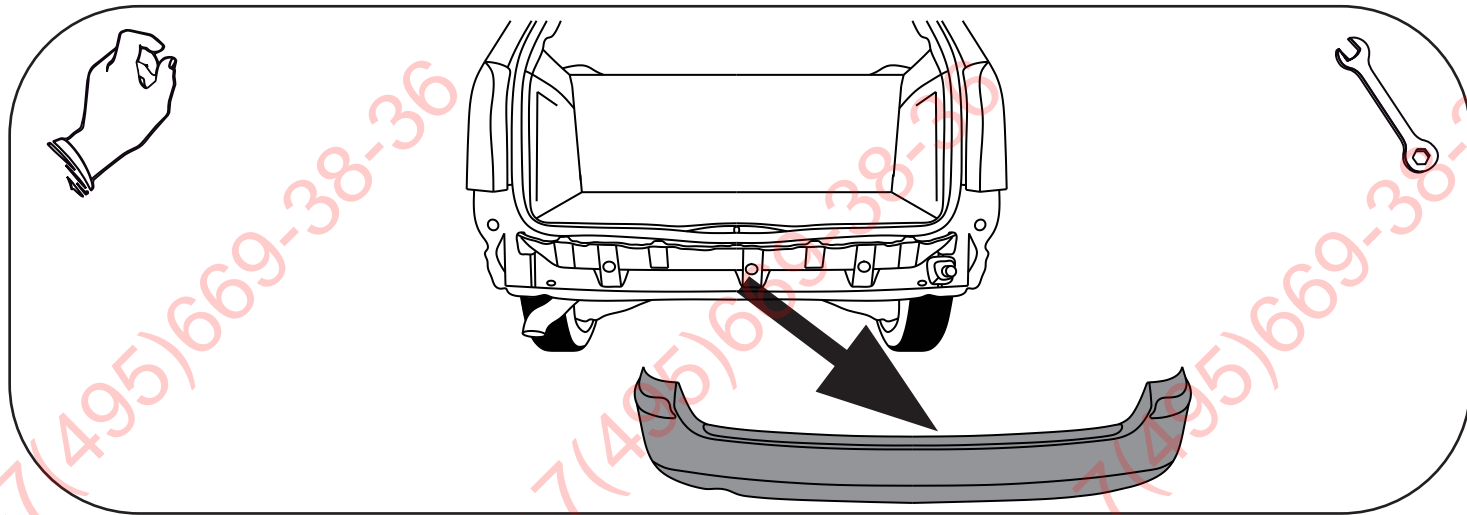

ФАРКОГ.РФ

