



05/1993 - 09/2000  
10/2000 - 12/2006

FORD MONDEO com.

Cat. No. E/028

E20

E20-55R-01-1090

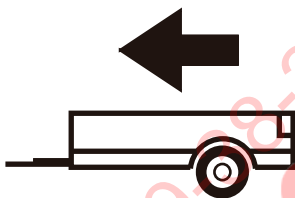

1800Kg

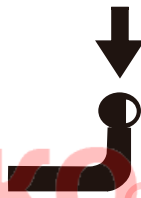

75Kg

**D** = 11,00kN

**D (kN) =**



MAX kg

x

MAX kg

x 0,00981



MAX kg

+

MAX kg

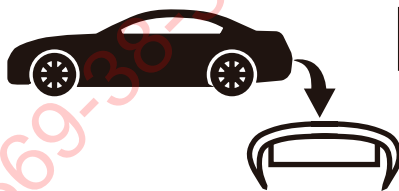

IMIOLA HAK-POL

96-111 KOWIESY, CHOJNATA 23A, POLAND

tel. +48 46 831 73 31, fax +48 831 74 29

e-mail: office@imiola.pl, www.imiola.pl

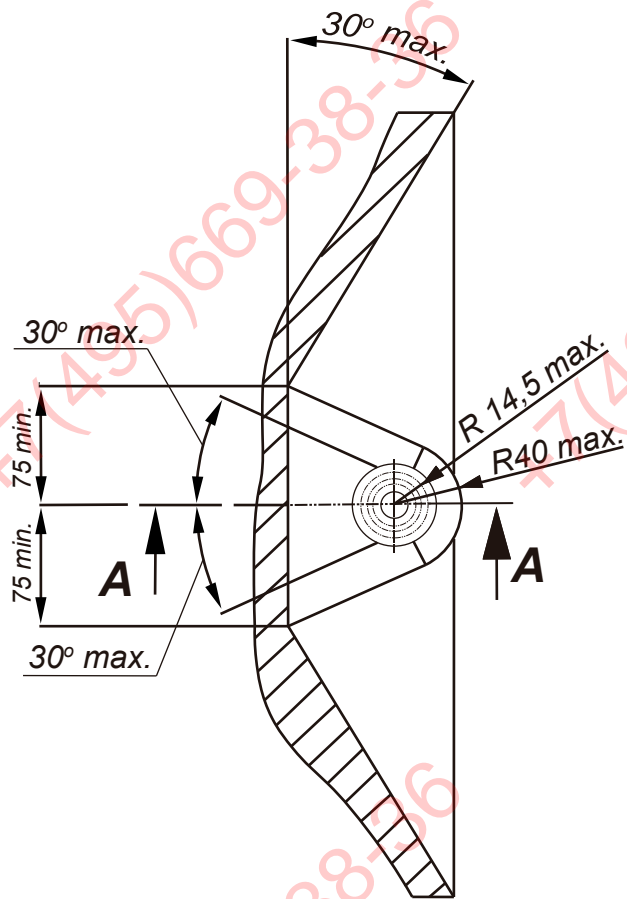

### PRZEKRÓJ A-A

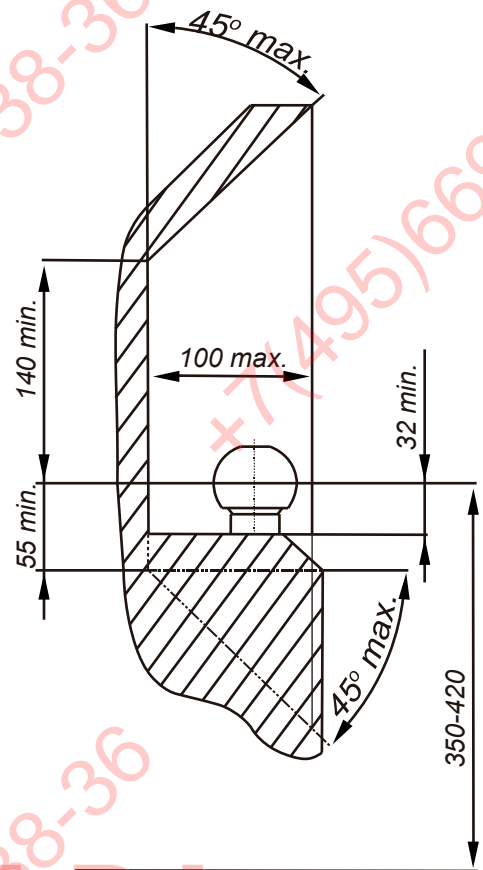

**PL** Należy zagwarantować przestrzeń swobodną według załącznika VII, rysunek 25a/b Regulaminu EKG ONZ 55.01 przy dopuszczalnym ciężarze całkowitym pojazdu.

**F** L'espace libre doit être garanti conformément à l'annexe VII, illustration de la réglementation 55.01 CE pour un poids total en charge autorisé du véhicule.

**GB** The clearance specified in appendix VII, diagram 25a/b of Regulation No. 55.01 UN EU must be guaranteed at laden weight of the vehicle.

**D** Der Freiraum nach Anhang VII, Abbildung 25a/b der Vorschriften 55.01 EG ist zu gewährleisten bei zulässigem Gesamtgewicht des Fahrzeuges.

Moment skręcający dla śrub i nakrętek (8.8) Torgue settings for nuts and bolts (8.8)	
M8	25Nm
M10	55Nm
M12	85Nm
M14	135Nm
M16	195Nm

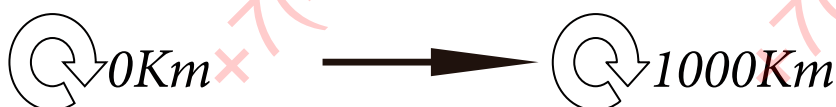

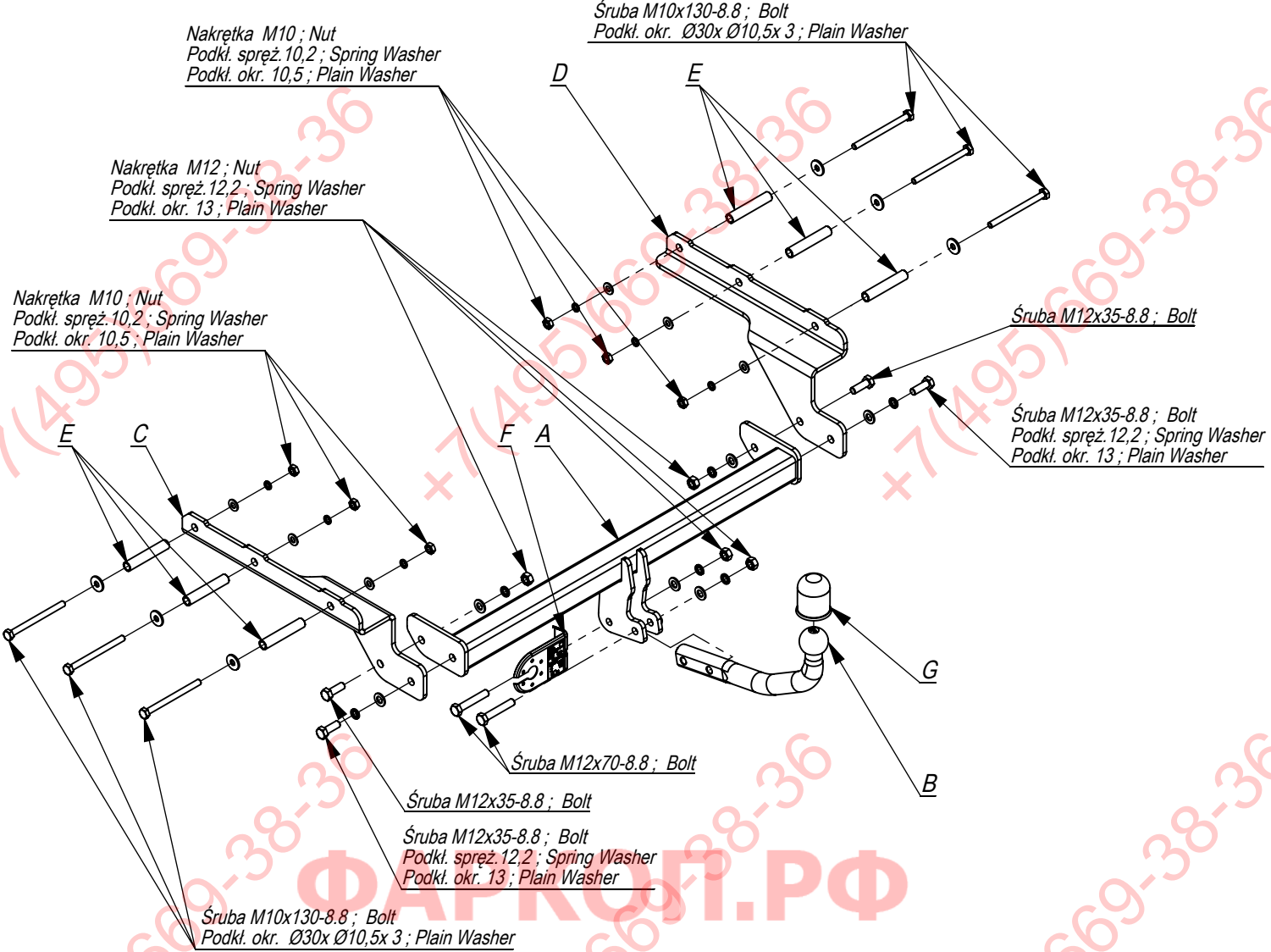

	A	x1		M12x70	2
	B	x1		M12x35	4
	C	x1		M10x130	6
	D	x1		M12	4
	E	x6		M10	6
	F	x1		Ø30xØ10,5x3	6
	G	x1		13	6
				10,5	6
				12,2	6
				10,2	6

Nakrętka M10 ; Nut  
Podkl. spręż. 10,2 ; Spring Washer  
Podkl. okr. 10,5 ; Plain Washer

Nakrętka M12 ; Nut  
Podkl. spręż. 12,2 ; Spring Washer  
Podkl. okr. 13 ; Plain Washer

Nakrętka M10 ; Nut  
Podkl. spręż. 10,2 ; Spring Washer  
Podkl. okr. 10,5 ; Plain Washer

D Pkt. 1

E

E C Pkt. 1

F A

Pkt. 2

Pkt. 2 Śruba M12x70-8.8 ; Bolt

Śruba M12x35-8.8 ; Bolt

Śruba M12x35-8.8 ; Bolt  
Podkl. spręż. 12,2 ; Spring Washer  
Podkl. okr. 13 ; Plain Washer

Śruba M10x130-8.8 ; Bolt  
Podkl. okr. Ø30x Ø10,5x 3 ; Plain Washer

Śruba M12x35-8.8 ; Bolt

Śruba M12x35-8.8 ; Bolt  
Podkl. spręż. 12,2 ; Spring Washer  
Podkl. okr. 13 ; Plain Washer

G

B

Śruba M10x130-8.8 ; Bolt  
Podkl. okr. Ø30x Ø10,5x 3 ; Plain Washer

Nr katalogowy E/028  
Marka Ford Mondeo combi

od 93-12/06

96-111 Kowiesy, Chojnata 23 A  
tel. +48 46 831 73 31

**MIOLA**  
HAKPOL

- W technologiczne otwory w podłużnicach włożyć tuleje dystansowe  $\text{Ø } 18 \times 94$  wraz ze śrubami M10x130 8.8 stosując powiększone podkładki po zewnętrznej stronie podłużnic.
- Na wystające śruby nałożyć elementy C i D i lekko skręcić.
- Do elementów C i D dokręcić belkę haka A śrubami M12x35 8.8.
- Wszystkie śruby dokręcić z momentem skręcającym jak w tabeli.
- Przykręcić kulę i blachę gniazda elektrycznego śrubami M12x70 8.8.
- Podłączyć instalację elektryczną.

- Insert the distance sleeves  $\text{Ø } 18 \times 94$  and bolts M10x130 8.8 in the technological holes of the metal clamps, using the large washers outside of the metal clamps.
- Put the elements C and D on the protruding bolts and screw slightly.
- Screw the main bar A to the elements C and D with bolts M12x35 8.8.
- Tighten all the bolts according to the torque setting- see the table.
- Fix the ball and electric plate with bolts M12x70 8.8.
- Connect the electric wires.

- Enfiler les douilles de distance  $\text{Ø } 18 \times 94$  dans des trous technologiques dans les longerons avec les boulons M10x130 8.8 en utilisant les rondelles agrandies du côté extérieur des longerons.
- Mettre les éléments C et D sur les boulons et les serrer légèrement.
- Serrer la poutre du crochet d'attelage avec les éléments C et D à l'aide des boulons M12x40 8.8.
- Serrer tous les boulons avec un couple de serrage selon tableau.
- Visser le crochet d'attelage et socle de prise électrique à l'aide des boulons M12x70 8.8.
- Raccorder le circuit électrique.

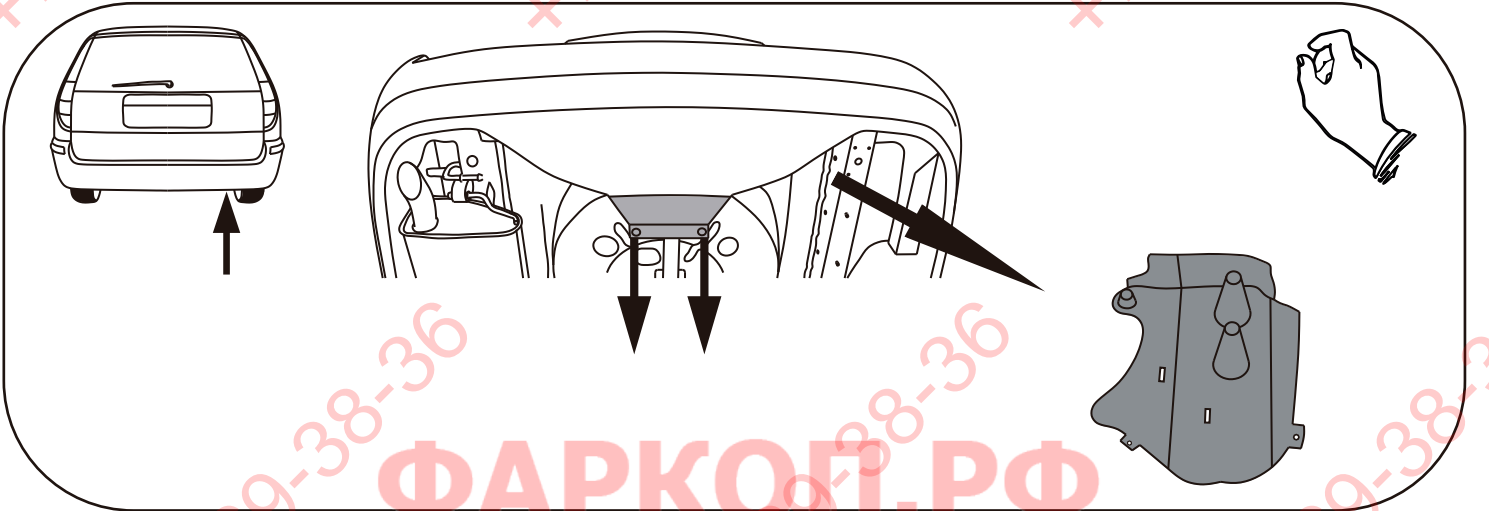
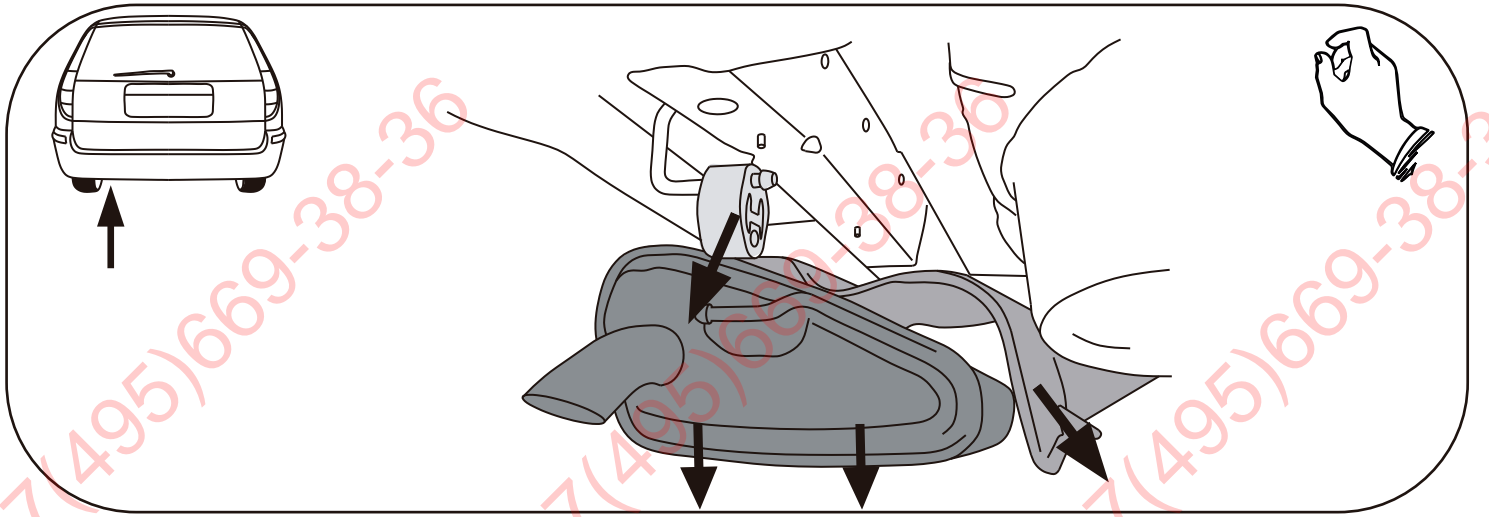

ФАРКОП.РФ

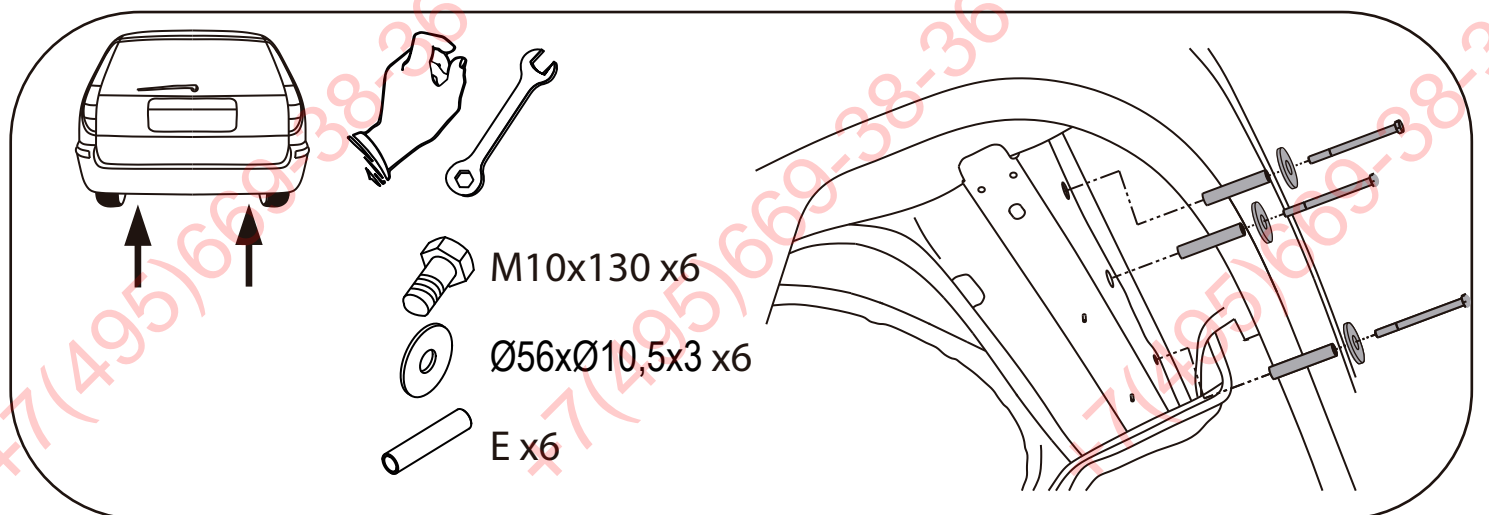
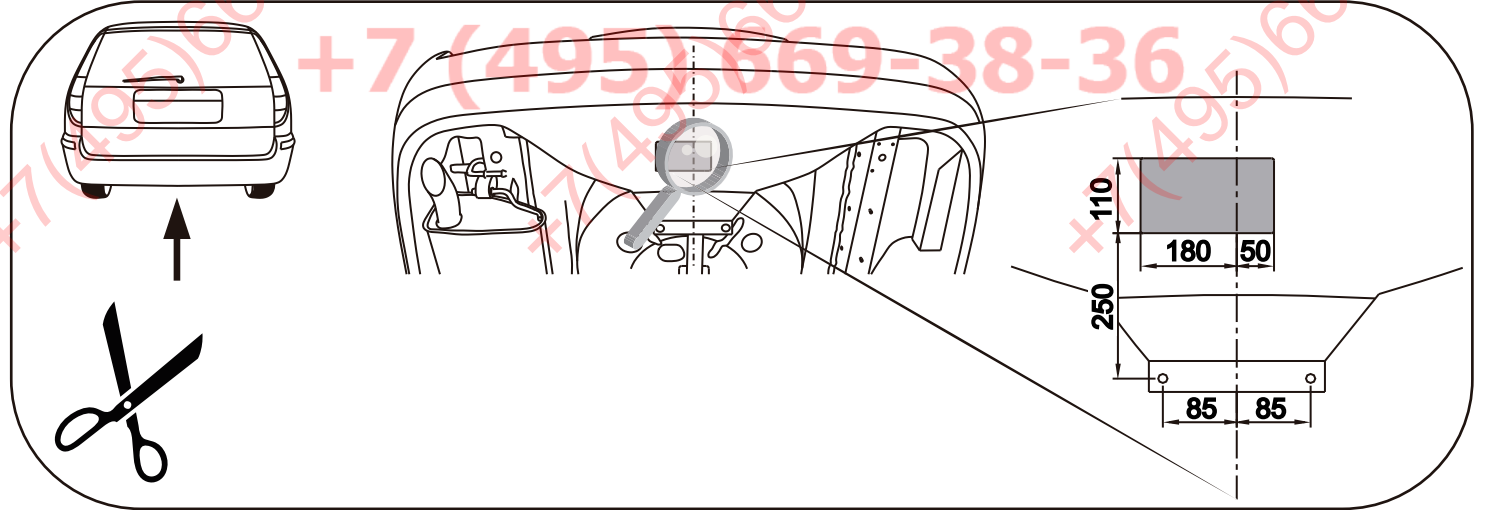

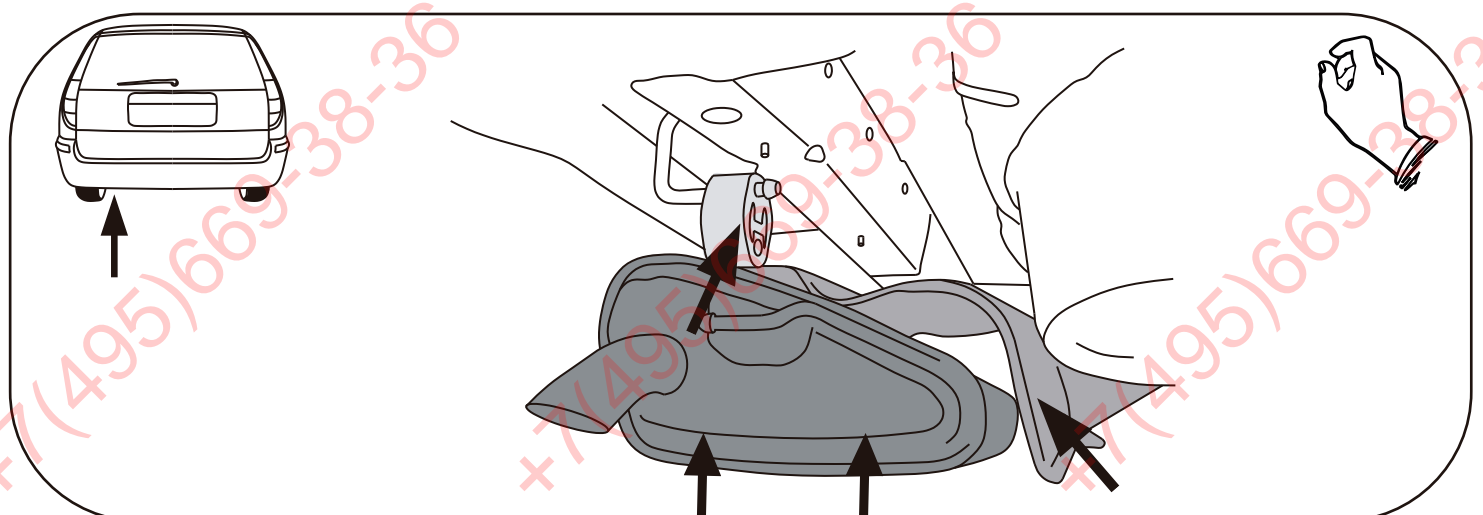
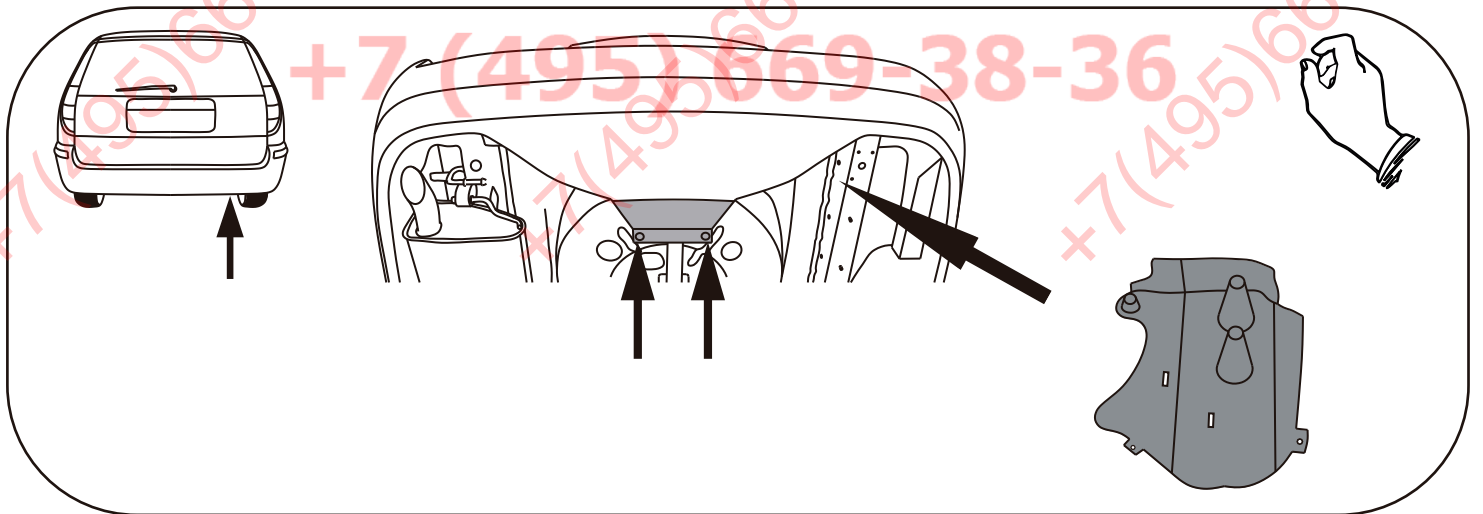
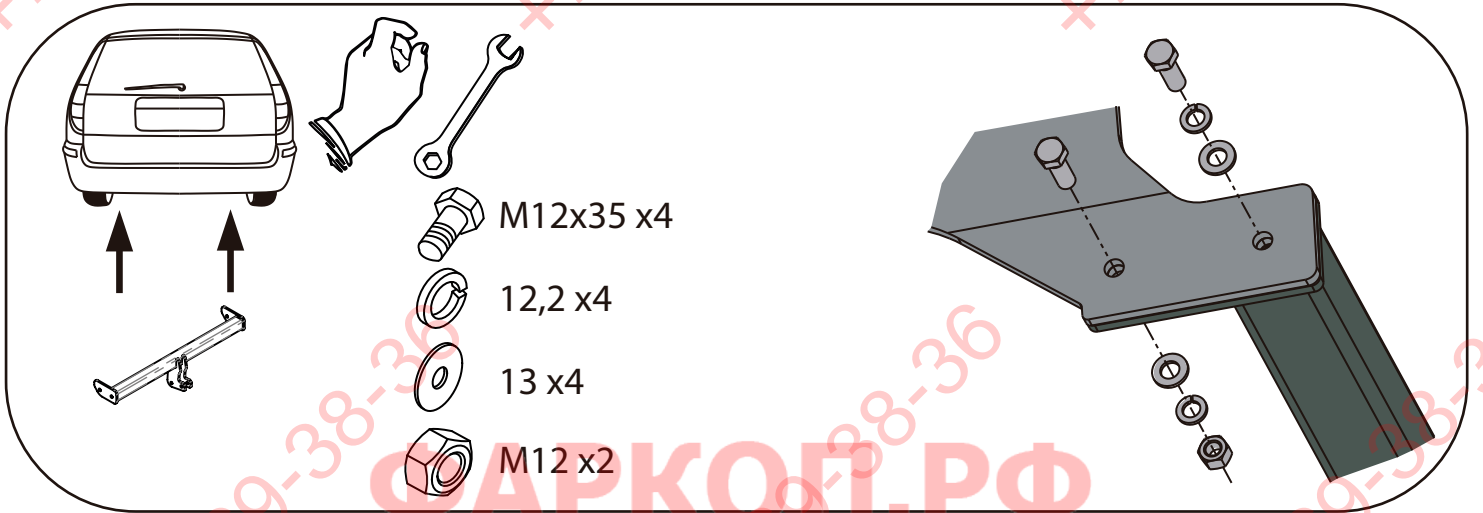
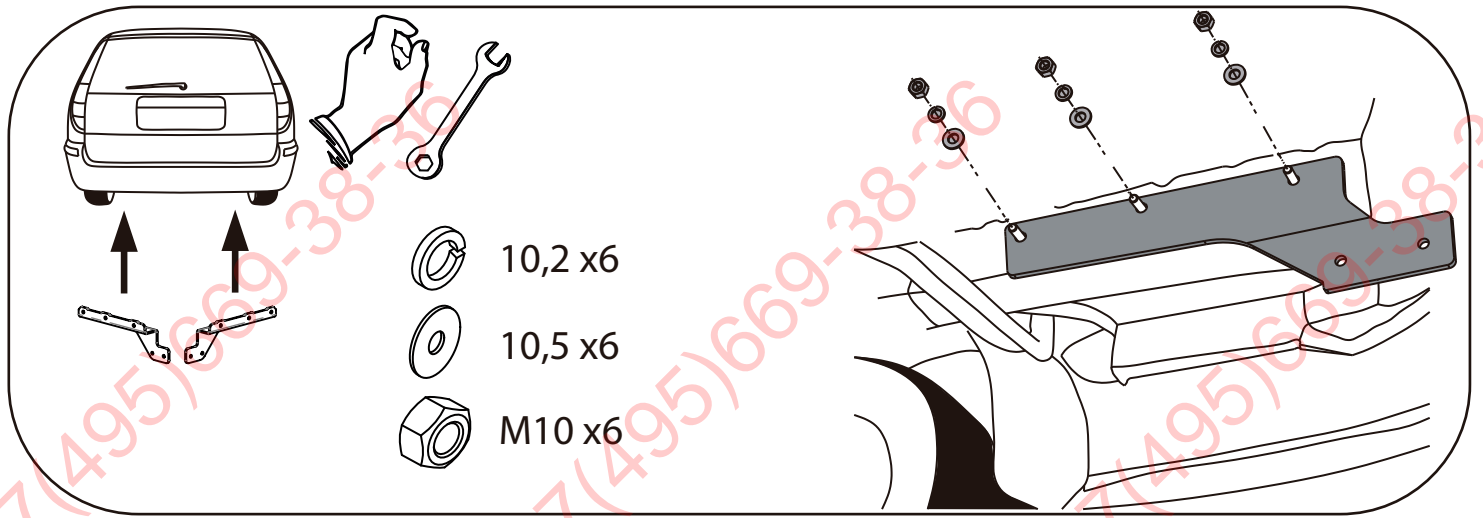

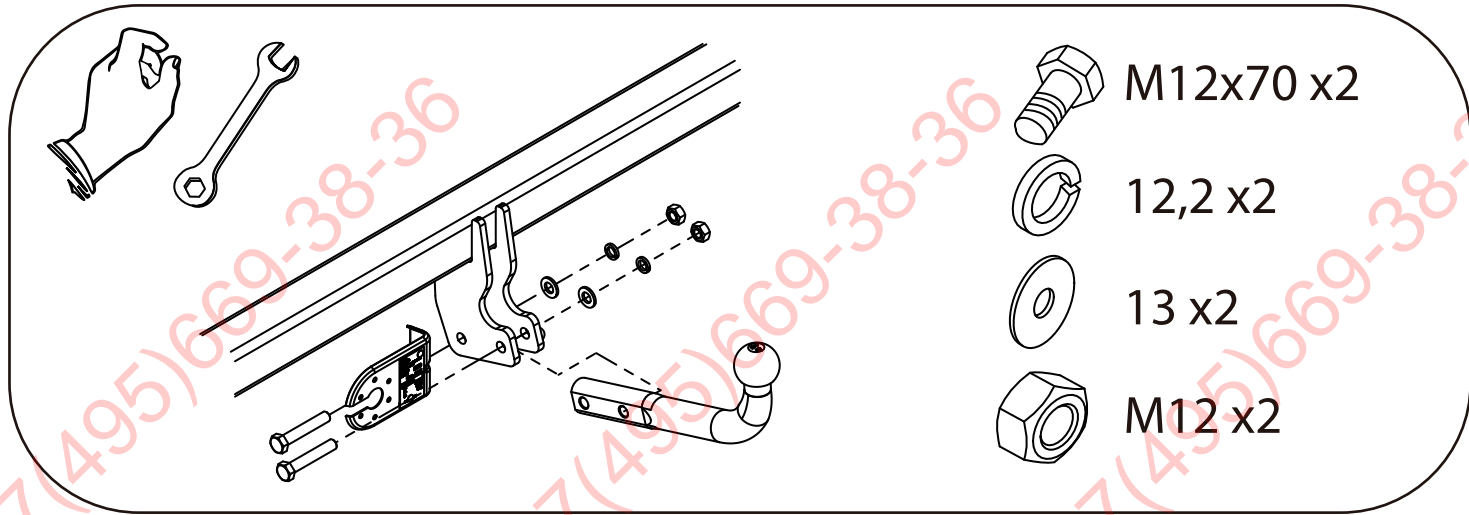

**ФАРКОГ.РФ**

**+7 (495) 669-38-36**