



02/2012 -

## FIAT PANDA III

Cat. No. **F/032**

**E20**

E20 55R-01 4076

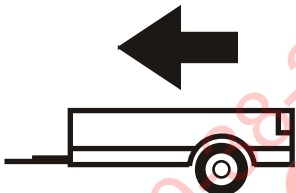

1000kg



70kg

**D** = 6,10kN

**D (kN) =**



MAX kg

x

MAX kg

x 0,00981



MAX kg

+

MAX kg



IMIOLA HAK-POL

96-111 KOWIESY, CHOJNATA 23A, POLAND

Tel. + 48 46 831 73 31, fax +48 831 74 29

e-mail: office@imiola.pl, www.imiola.pl

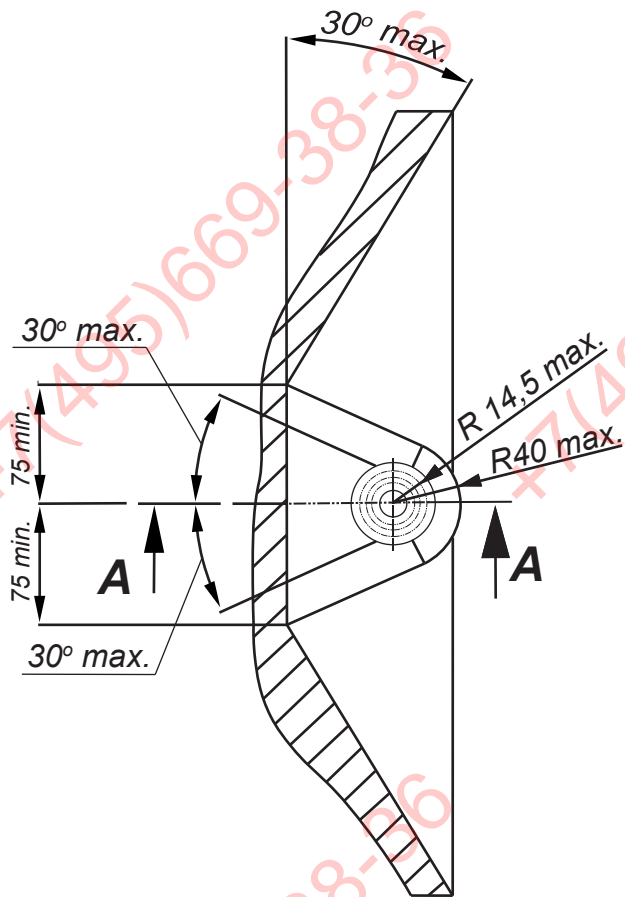

**PRZEKRÓJ A-A**

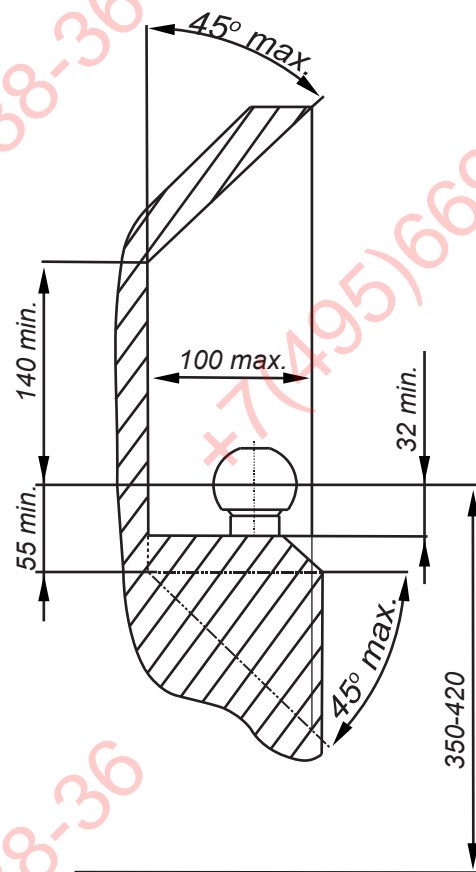

**ФАРКОГ.РФ**

**PL** Należy zagwarantować przestrzeń swobodną według załącznika VII, rysunek 25a/b Regulaminu EKG ONZ 55.01 przy dopuszczalnym ciężarze całkowitym pojazdu.

**F** L'espace libre doit être garanti conformément à l'annexe VII, illustration de la réglementation 55.01 CE pour un poids total en charge autorisé du véhicule.

**GB** The clearance specified in appendix VII, diagram 25a/b of Regulation No. 55.01 UN EU must be guaranteed at laden weight of the vehicle.

**D** Der Freiraum nach Anhang VII, Abbildung 25a/b der Vorschriften 55.01 EG ist zu gew 25a/b abzuhalten bei zulässigem Gesamtgewicht des Fahrzeuges.

Moment skracający dla śrub i nakrętek (8.8) Torque settings for nuts and bolts (8.8)	
M8	25Nm
M10	55Nm
M12	85Nm
M14	135Nm
M16	195Nm



Šruba M12x40-8.8 ; Bolt  
Podkl. spręż.12,2 ; Spring Washer  
Podkl. okr. 13 ; Plain Washer

Nakrętka M 6 ; Nut  
Podkl. spręż.6,2 ; Spring Washer  
Podkl. okr. Ø18x Ø6,5x 1,5 ; Plain Washer

Šruba M 8x35-8.8 ; Bolt

Šruba M 6x20-8.8 ; Bolt  
Podkl. okr. Ø18x Ø6,5x 1,5 ; Plain Washer

Nakrętka M10 ; Nut  
Podkl. spręż.10,2 ; Spring Washer  
Podkl. okr. Ø30x Ø10,5x 3 ; Plain Washer

Nakrętka M 6 ; Nut  
Podkl. spręż.6,2 ; Spring Washer  
Podkl. okr. Ø18x Ø6,5x 1,5 ; Plain Washer

Nakrętka M 8 ; Nut  
Podkl. spręż.8,2 ; Spring Washer  
Podkl. okr. Ø23x Ø8,5x 2 ; Plain Washer

Nakrętka M10 ; Nut  
Podkl. spręż.10,2 ; Spring Washer  
Podkl. okr. Ø30x Ø10,5x 3 ; Plain Washer

Šruba M10x35-8.8 ; Bolt  
Podkl. okr. Ø30x Ø10,5x 3 ; Plain Washer

Nakrętka M 8 ; Nut  
Podkl. spręż.8,2 ; Spring Washer  
Podkl. okr. 8,4 ; Plain Washer

Šruba M12x40-8.8 ; Bolt  
Podkl. spręż.12,2 ; Spring Washer  
Podkl. okr. 13 ; Plain Washer

Šruba M 8x35-8.8 ; Bolt

Nakrętka M12 ; Nut  
Podkl. spręż.12,2 ; Spring Washer  
Podkl. okr. 13 ; Plain Washer

Nakrętka M 8 ; Nut  
Podkl. spręż.8,2 ; Spring Washer  
Podkl. okr. Ø23x Ø8,5x 2 ; Plain Washer











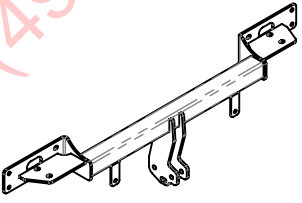
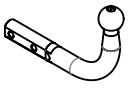
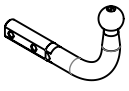
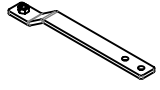
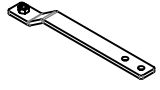





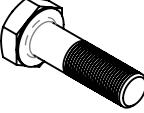

Nakrętka M 8 ; Nut  
Podkl. spręż.8,2 ; Spring Washer  
Podkl. okr. Ø23x Ø8,5x 2 ; Plain Washer

Šruba M12x70-8.8 ; Bolt

Nakrętka M 8 ; Nut  
Podkl. spręż.8,2 ; Spring Washer  
Podkl. okr. 8,4 ; Plain Washer

Šruba M10x35-8.8 ; Bolt  
Podkl. okr. Ø30x Ø10,5x 3 ; Plain Washer

Šruba M 6x20-8.8 ; Bolt  
Podkl. okr. Ø18x Ø6,5x 1,5 ; Plain Washer

	A	x1		M12x70	2
	B	x1		M12x40	2
	C	x2		M10x35	4
	D	x2		M8x35	2
	E	x1		M6x20	2
	F	x1		M12	2
				M10	4
				M8	10
				M6	2
				Ø30xØ10,5x3	8
				Ø23xØ8,5x2	8
				Ø18xØ6,5x1,5	4
				13	4
				8,5	2
				12,2	4
				10,2	8
				8,2	10
				6,1	2

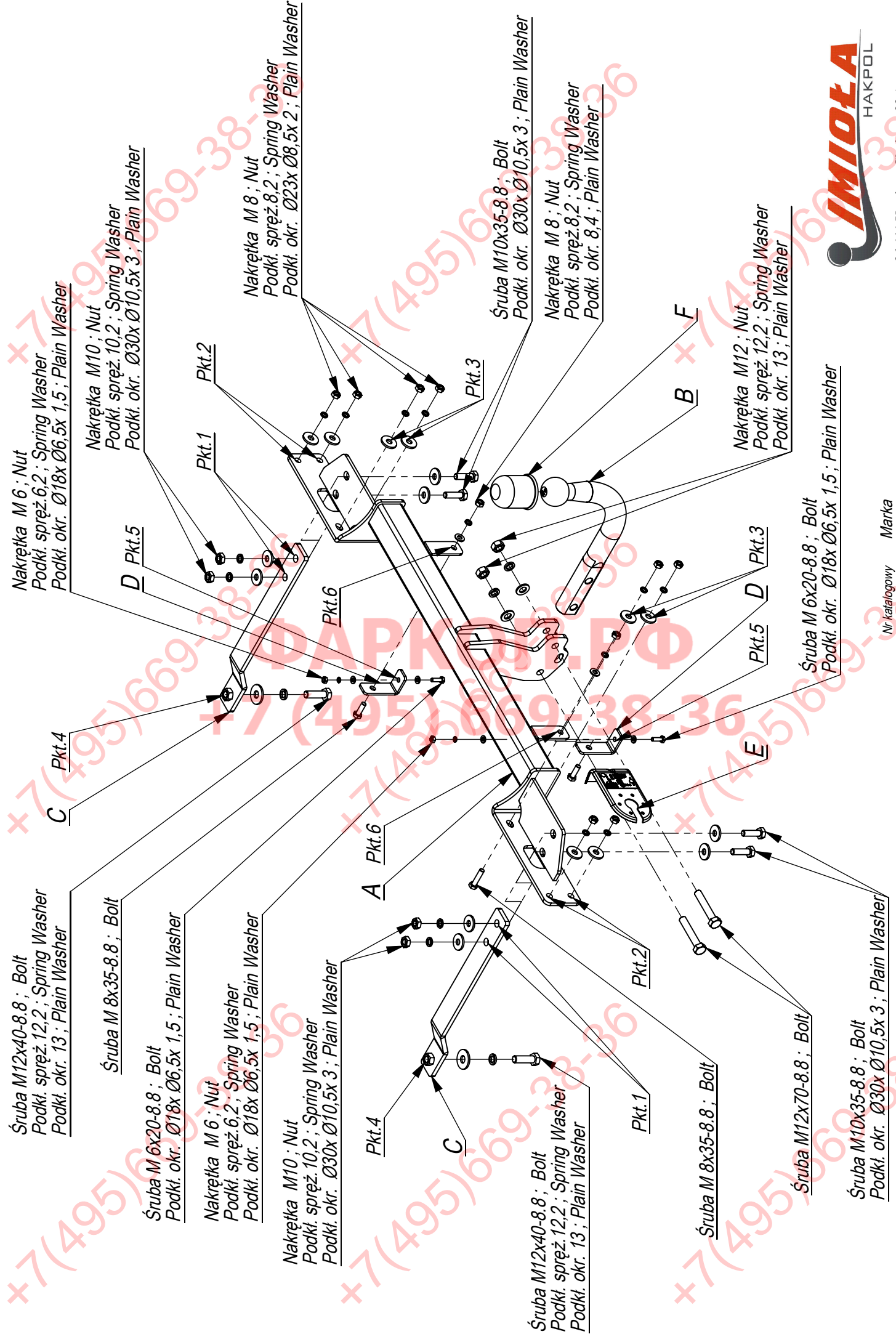

Śruba M12x40-8.8 ; Bolt  
 Podkl. spręż. 12,2 ; Spring Washer  
 Podkl. okr. 13 ; Plain Washer

Śruba M 8x35-8.8 ; Bolt

Śruba M 6x20-8.8 ; Bolt  
 Podkl. okr. Ø18x Ø6,5x 1,5 ; Plain Washer

Nakrętka M 6 ; Nut  
 Podkl. spręż. 6,2 ; Spring Washer  
 Podkl. okr. Ø18x Ø6,5x 1,5 ; Plain Washer

Nakrętka M10 ; Nut  
 Podkl. spręż. 10,2 ; Spring Washer  
 Podkl. okr. Ø30x Ø10,5x 3 ; Plain Washer

Śruba M12x40-8.8 ; Bolt  
 Podkl. spręż. 12,2 ; Spring Washer  
 Podkl. okr. 13 ; Plain Washer

Śruba M 8x35-8.8 ; Bolt

Śruba M12x70-8.8 ; Bolt

Śruba M 6x20-8.8 ; Bolt  
 Podkl. okr. Ø18x Ø6,5x 1,5 ; Plain Washer

Nakrętka M 6 ; Nut  
 Podkl. spręż. 6,2 ; Spring Washer  
 Podkl. okr. Ø18x Ø6,5x 1,5 ; Plain Washer

Nakrętka M10 ; Nut  
 Podkl. spręż. 10,2 ; Spring Washer  
 Podkl. okr. Ø30x Ø10,5x 3 ; Plain Washer

Śruba M 8x35-8.8 ; Bolt

Śruba M10x35-8.8 ; Bolt  
 Podkl. okr. Ø30x Ø10,5x 3 ; Plain Washer

Nakrętka M 6 ; Nut  
 Podkl. spręż. 6,2 ; Spring Washer  
 Podkl. okr. Ø18x Ø6,5x 1,5 ; Plain Washer

Nakrętka M10 ; Nut  
 Podkl. spręż. 10,2 ; Spring Washer  
 Podkl. okr. Ø30x Ø10,5x 3 ; Plain Washer

Nakrętka M 8 ; Nut  
 Podkl. spręż. 8,2 ; Spring Washer  
 Podkl. okr. Ø23x Ø8,5x 2 ; Plain Washer

Śruba M10x35-8.8 ; Bolt  
 Podkl. okr. Ø30x Ø10,5x 3 ; Plain Washer

Nakrętka M 8 ; Nut  
 Podkl. spręż. 8,2 ; Spring Washer  
 Podkl. okr. 8,4 ; Plain Washer

Nakrętka M12 ; Nut  
 Podkl. spręż. 12,2 ; Spring Washer  
 Podkl. okr. 13 ; Plain Washer

Śruba M 6x20-8.8 ; Bolt  
 Podkl. okr. Ø18x Ø6,5x 1,5 ; Plain Washer

Śruba M 8x35-8.8 ; Bolt

Śruba M 8x35-8.8 ; Bolt

Śruba M 6x20-8.8 ; Bolt  
 Podkl. okr. Ø18x Ø6,5x 1,5 ; Plain Washer

Śruba M 6x20-8.8 ; Bolt  
 Podkl. okr. Ø18x Ø6,5x 1,5 ; Plain Washer

Śruba M 6x20-8.8 ; Bolt  
 Podkl. okr. Ø18x Ø6,5x 1,5 ; Plain Washer



96-111 Kowiesy, Chojnata 23 A  
 tel. +48 46 831 73 31

Nr katalogowy F/032  
 Marka Fiat Panda III  
 od 02/2012 ->

- Odkręcić zderzak i belkę zderzeniową (nie będzie już wykorzystana).
- Opuścić tłumik z zawiesia.
- Elementy C wsunąć w podłużnice i przykręcić śrubami M12x40(pkt4).
- Belkę haka A przykręcić do tylnego pasa śrubami M8x35 8.8 (pkt3) nakrętkami M8 (pkt2) oraz z elementami C śrubami M10x 35 8.8. (pkt1).
- Dokręcić wszystkie śruby z momentem według tabeli.
- Przykręcić zderzak stosując elementy D

- Unscrew the bumper and bumper bar (it will not be used any more).
- Lower the muffler from the hanger.
- Insert the elements C in the frame side members and screw with bolts M12x40 8.8 (point 4).
- Screw the main bar A to the rear belt with bolts M8x35 8.8 (point 3) and nuts M8 (point 2), and screw together with the elements C with bolts M10x35 8.8 (point 1).
- Tighten all the bolts according to the torque setting- see the table.
- Screw the bumper using the elements D.
- Fix the ball and electric plate.
- Connect the electric wires.

- Die Stoßstange abschrauben.
- Den Stoßstange Balken abschrauben (wird nicht wieder benutzt).
- Den Schalldämpfer vom Halter absenken.
- Elemente C in die Längsträger einschieben und mit anschrauben Schrauben M12x45 8.8 (Punkt 4).
- Den Träger des A-Hakens an das Abschlussblech mit Schrauben M8x35 8.8 (Punkt 3) und an die C-Elemente mit Schrauben M10x35 8,8 (Punkt 1) befestigen.
- Ziehen Sie alle Schrauben mit dem Drehmoment gemäß der Tabelle an.
- Schrauben Sie den Stoßfänger mit den Elementen D fest.

- Die Stoßstange abschrauben.
- Den Stoßstange Balken abschrauben (wird nicht wieder benutzt).
- Den Schalldämpfer vom Halter absenken.
- Elemente C in die Längsträger einschieben und mit anschrauben Schrauben M12x45 8.8 (Punkt 4).
- Den Träger des A-Hakens an das Abschlussblech mit Schrauben M8x35 8.8 (Punkt 3) und an die C-Elemente mit Schrauben M10x35 8,8 (Punkt 1) befestigen.
- Ziehen Sie alle Schrauben mit dem Drehmoment gemäß der Tabelle an.
- Schrauben Sie den Stoßfänger mit den Elementen D fest.

- Desmontar el parachoques.
- Desenroscar la viga de choques (ya no se montará).
- Bajar el silenciador de la suspensión.
- Insertar los elementos C en el chasis y apretar con tornillos M12x40 8.8 (punto 4).
- Apretar la barra del gancho A a la correa trasera con pernos M8x35 8.8 (punto 3) y con tuercas M8 (elemento 2) y con elementos C con tornillos M10x 35 8.8.
- Apretar todos los tornillos con el par según la tabla anterior..
- Atornillar el parachoques usando elementos D.



