



2002 - 2009

MERCEDES E-SERIES (W-211)
4 DOORS SALOON

Cat. No. **M/027**

e20

e20*94/20*0507*00

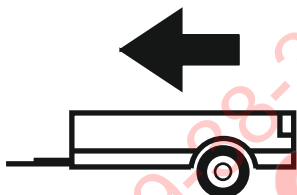

2200kg



75kg

D = 10,70kN

D (kN) =



MAX kg

x

MAX kg

x 0,00981



MAX kg

+

MAX kg

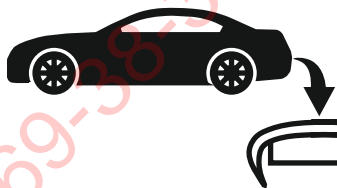

IMIOLA HAK-POL

96-111 KOWIESY, CHOJNATA 23A, POLAND

Tel. + 48 46 831 73 31, fax +48 831 74 29

e-mail: office@imiola.pl, www.imiola.pl

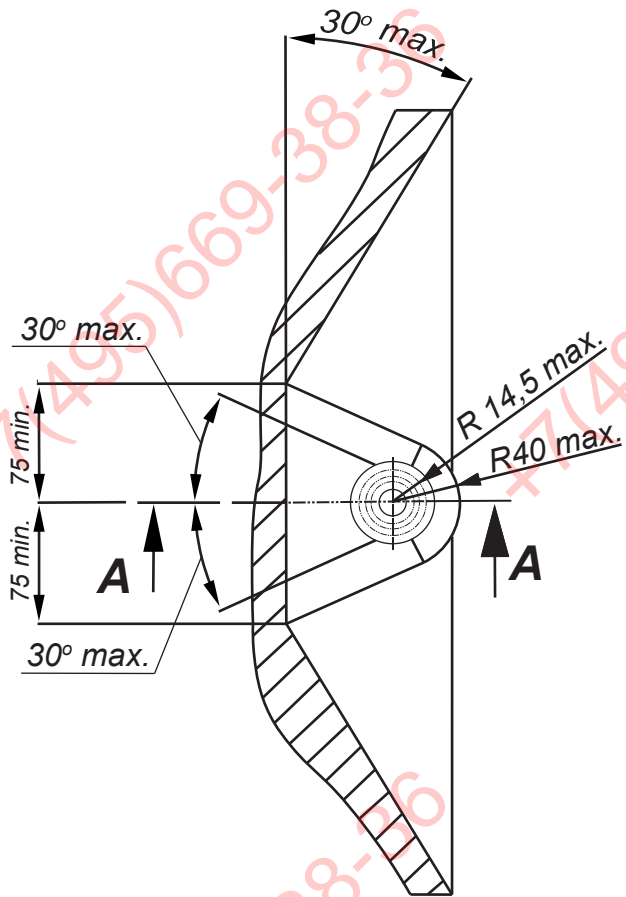

PRZEKRÓJ A-A

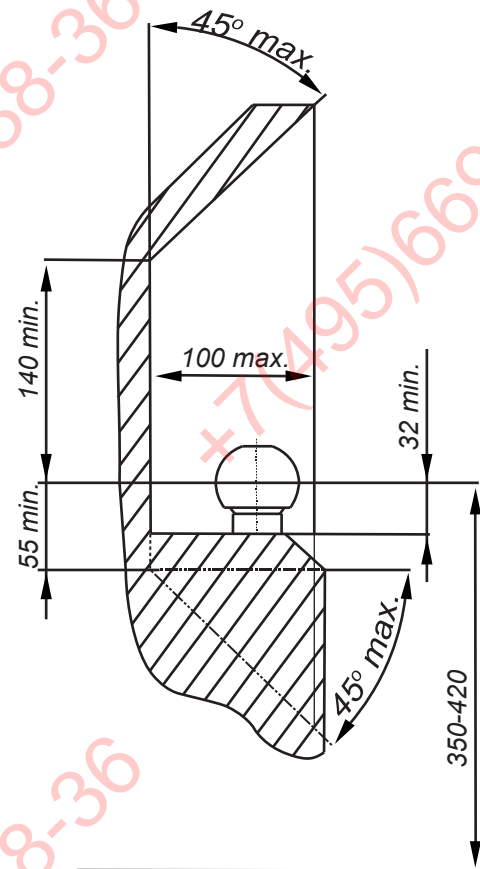

ФАРКОЛ.РФ

PL Należy zagwarantować przestrzeń swobodną według załącznika VII, rysunek 25a/b Regulaminu EKG ONZ 55.01 przy dopuszczalnym ciężarze całkowitym pojazdu.

F L'espace libre doit être garanti conformément à l'annexe VII, illustration de la réglementation 55.01 CE pour un poids total en charge autorisé du véhicule.

GB The clearance specified in appendix VII, diagram 25a/b of Regulation No. 55.01 UN EU must be guaranteed at laden weight of the vehicle.

D Der Freiraum nach Anhang VII, Abbildung 25a/b der Vorschriften 55.01 EG ist zu gew 25a/b abzuhalten bei zulässigem Gesamtgewicht des Fahrzeuges.

Moment skręcający dla śrub i nakrętek (8.8) Torque settings for nuts and bolts (8.8)	
M8	25Nm
M10	55Nm
M12	85Nm
M14	135Nm
M16	195Nm



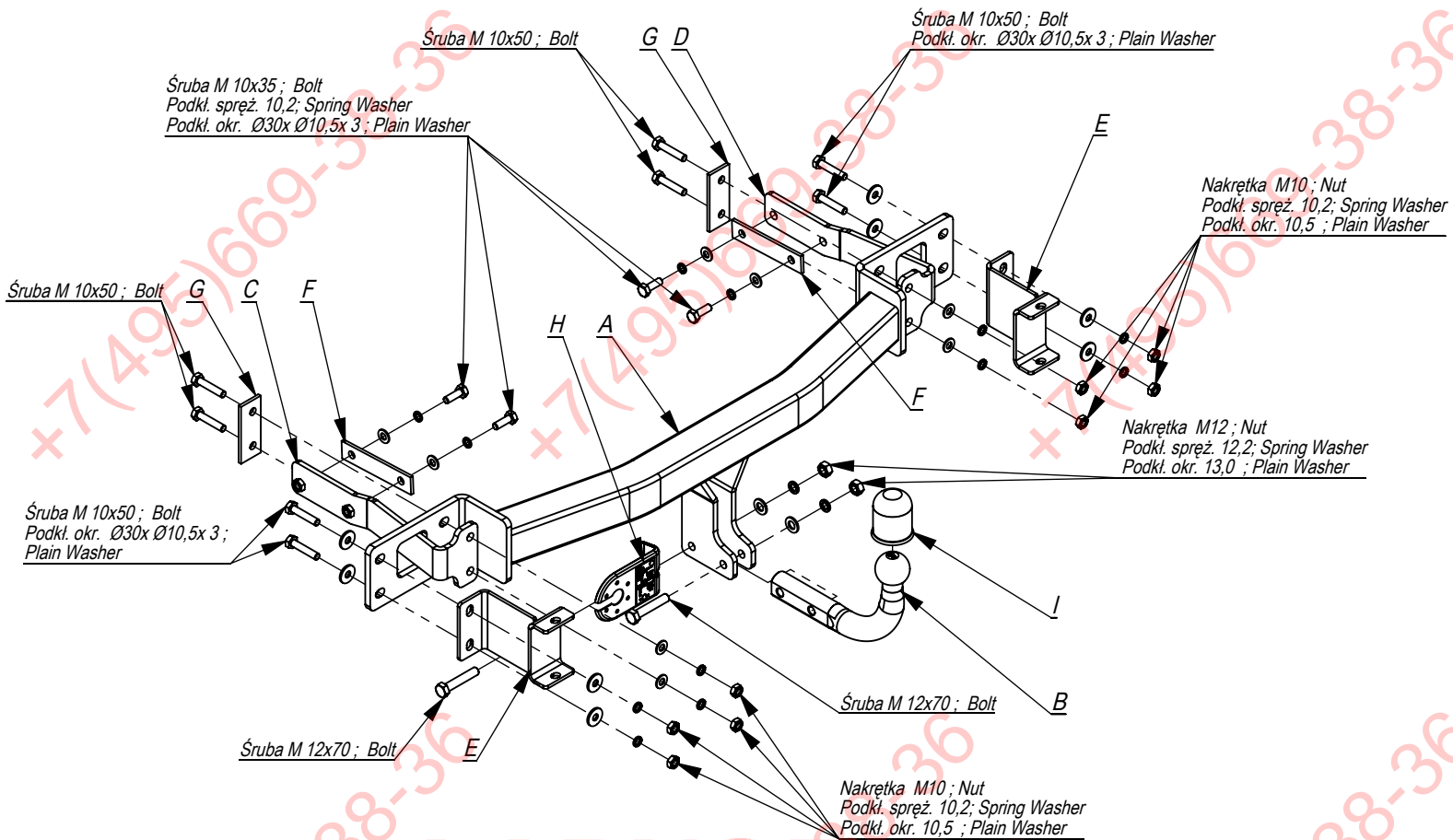

ФАРКОП.РФ

	A	x1		M12x70	2
	C	x1		M10x50	8
	D	x1		M10x35	4
	E	x2		M12	2
	F	x2		M10	8
	G	x2		Ø30xØ10,5x3	8
	H	x1		13	2
	I	x1		10,5	12
				12,2	2
				10,2	12

- Wymontować tylne i boczne osłony w bagażniku.
- Odkręcić zderzak oraz wsporniki, które nie będą już montowane.
- Od strony bagażnika przykręcić nakładki G i włożyć śruby M10x50 8.8 w technologiczne otwory, w tylnym pasie (pkt 1).
- Na wystające śruby włożyć belkę haka A. Do podłużnic włożyć elementy haka C i D. Skręcić lekko z belką haka A (pkt 1).
- Od wewnątrz bagażnika przykręcić elementy C i D do podłużnic śrubami M10x35 8.8 stosując nakładki F (pkt 2).
- Do uchwytów E przykręcić wypełnienie zderzaka używając oryginalnych śrub i nakrętek (pkt 2).
- Całość przykręcić do belki głównej śrubami M10x50 8.8 stosując powiększone podkładki.
- Zamontować zderzak.
- Dokręcić wszystkie śruby z momentem wg tabeli.
- Dokręcić kulę i blachę gniazda elektrycznego.
- Podłączyć instalację elektryczną.

- Disassemble the rear and side shields of the bumper.
- Unscrew the bumper and supporters (the supporters will not be used any more).
- Screw the plates G from the side of the boot and put the bolts M10x50 8.8 in the technological holes, in the rear belt of the car (point 1).
- Put the main bar A on the protruding bolts. Insert the elements C and D in the metal clamps. Screw slightly with the main bar A (point 1).
- Screw the elements C and D to the metal clamps from the inside of the boot with bolts M10x35 8.8 using plates F (point 2).
- Screw the lining of the bumper to the handles E using original bolts and nuts.
Screw the whole to the main bar with bolts M10x50 8.8 using the larger washers.
- Assemble the bumper.
- Tighten all the bolts according to the torque setting- see the table.
- Fix the ball and electric plate.
- Connect the electric wires.

- Démontez les carters postérieurs et latéraux dans le coffre.
- Dévissez le pare-chocs et les supports qui ne seront plus montés.
- Du côté du coffre, visser les rondelles G et infiler les boulons M10x50 8.8 dans des trous technologiques, dans la bande postérieure (point 1)
- Mettre la poutre du crochet A sur les boulons. Infiler les éléments du crochet C et D dans les longerons. Visser légèrement avec la poutre du crochet A (point 1).
- Dans la partie interne du coffre, visser les éléments C et D aux longerons, en utilisant les boulons M10x35 8.8 et les rondelles F (point 2).
- Visser le remplissage du pare-chocs aux crochets E, en utilisant des boulons originaux et des rondelles (point 2). Visser tout à la poutre principale en utilisant les boulons M10x50 8.8, en utilisant les rondelles agrandies.
- Monter le pare-chocs.
- Serrer tous les boulons avec un couple de serrage selon tableau.
- Visser le crochet d'attelage et socle de prise électrique.
- Raccorder le circuit électrique.

- Den Hinter- und Seitenschutz im Koerraum demontieren.
- Die Stoßstange und die Stützen abschrauben, werden nicht mehr montiert.
- Von der Seite des Koerraumes, die Laschen G anschrauben und die Schrauben M10x50 8.8 in die vom Werk aus im hinteren Karosseriestreifen vorhandenen Öffnungen (Punkt 1) einlegen.
- Auf die herausragenden Schrauben den Querbalken A einlegen. In die Längsträger die Tragteile C und D schieben.
Mit dem Querbalken A (Punkt 1) locker verschrauben.
- Von innen des Koerraumes, die Tragteile C und D an die Längsträger mit den Schrauben M10x35 8.8, mit den Laschen F (Punkt 2) anschrauben.
- An die Gie E die Stoßstange Schürze mit den originellen Schrauben und Muttern (Punkt 2) anschrauben.
An den Querbalken mit den Schrauben M10x50 8.8, mit den vergrößerten Unterlegscheiben anschrauben.
- Die Stoßstange einbauen.
- Alle Schrauben mit dem in der Tabelle angegebenen Drehmoment festziehen.
- Die Kugel und die Steckdosenhalterung anschrauben.
- Die Elektroinstallation anschließen.

- Retire las cubiertas traseras y laterales del maletero.
- Desmontar el parachoques y los soportes, que ya no se monta.
- Apriete las cubiertas G desde el lado del maletero e inserte los pernos M10x50 8.8 en los orificios tecnologicos de la correa trasera (punto 1).
- En los pernos que sobresalen, inserte el gancho A. A los largueros, inserte los elementos de los ganchos C y D. Gire ligeramente con el gancho A del gancho A (punto 1).
- Desde el interior del maletero, sujete las partes C y D a los largueros con pernos M10x35 8.8, utilizando las superposiciones F (punto 2).
- Fijar el relleno del parachoques a los soportes E con los pernos y tuercas originales (punto 2). El conjunto esta atornillado a la viga principal con pernos M10x50 8.8 con arandelas ampliadas.
- Instalar el parachoques.
- Apretar todos los tornillos con el par segun la tabla anterior.
- Apretar la bola y la placa de la toma electrica.
- Conectar la instalacion electrica.

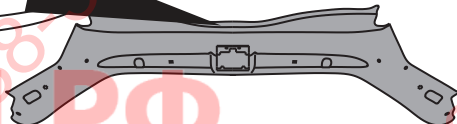
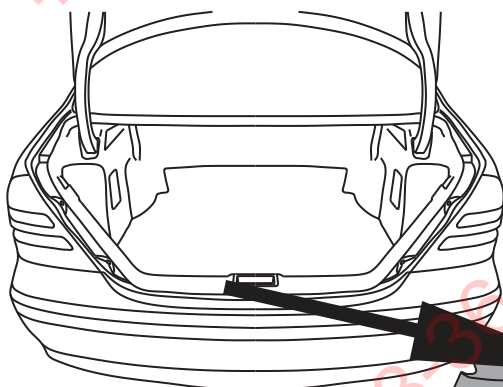
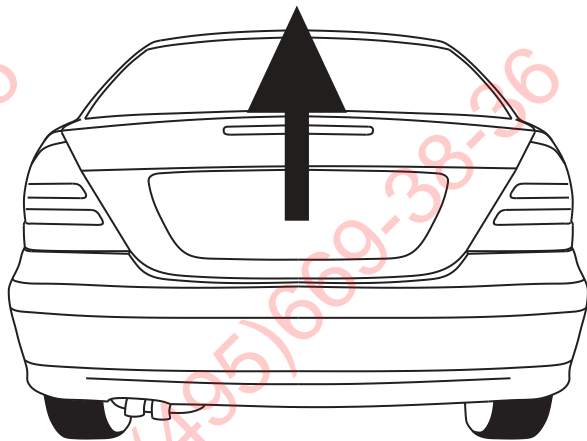

ФАРКОП.РФ

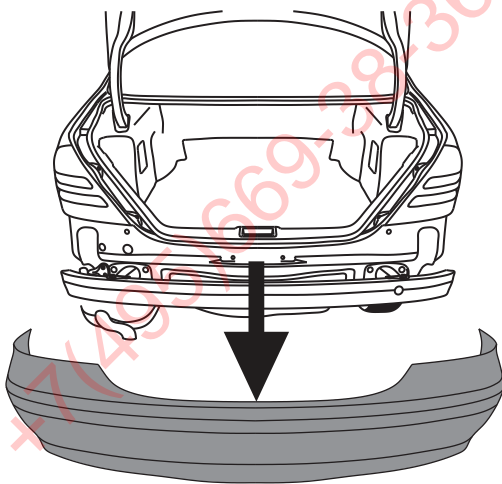
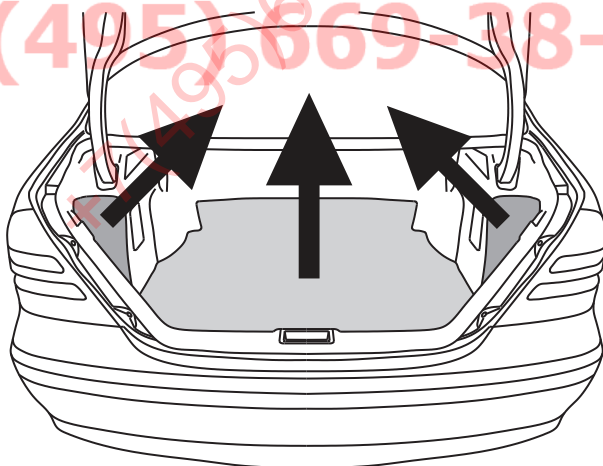

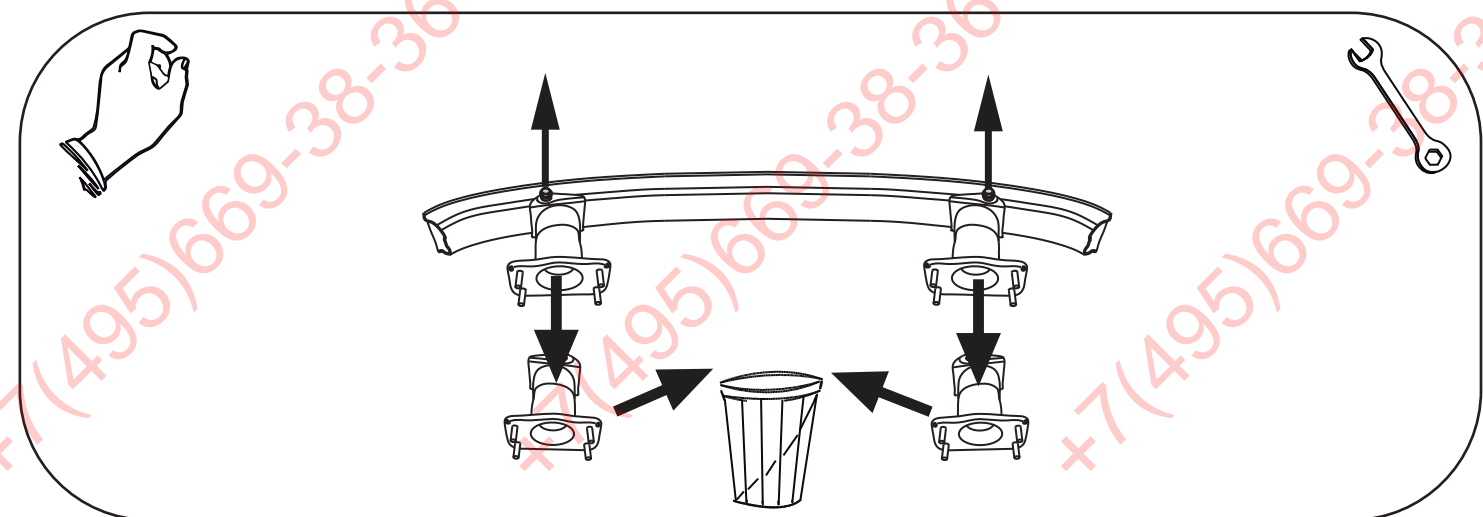
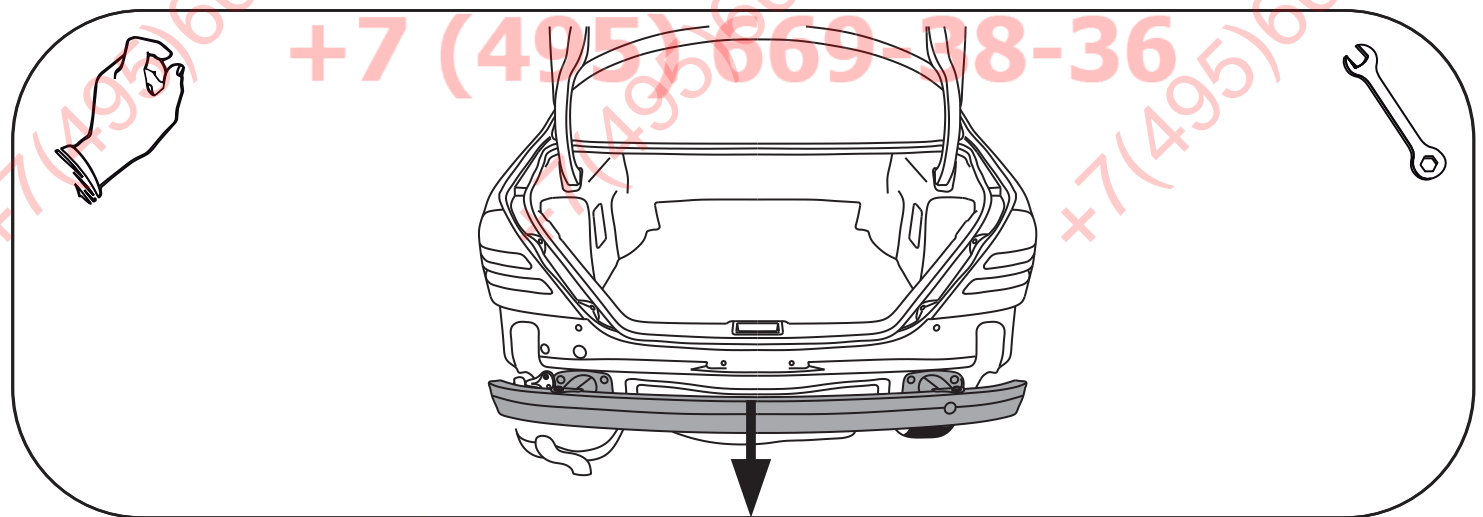
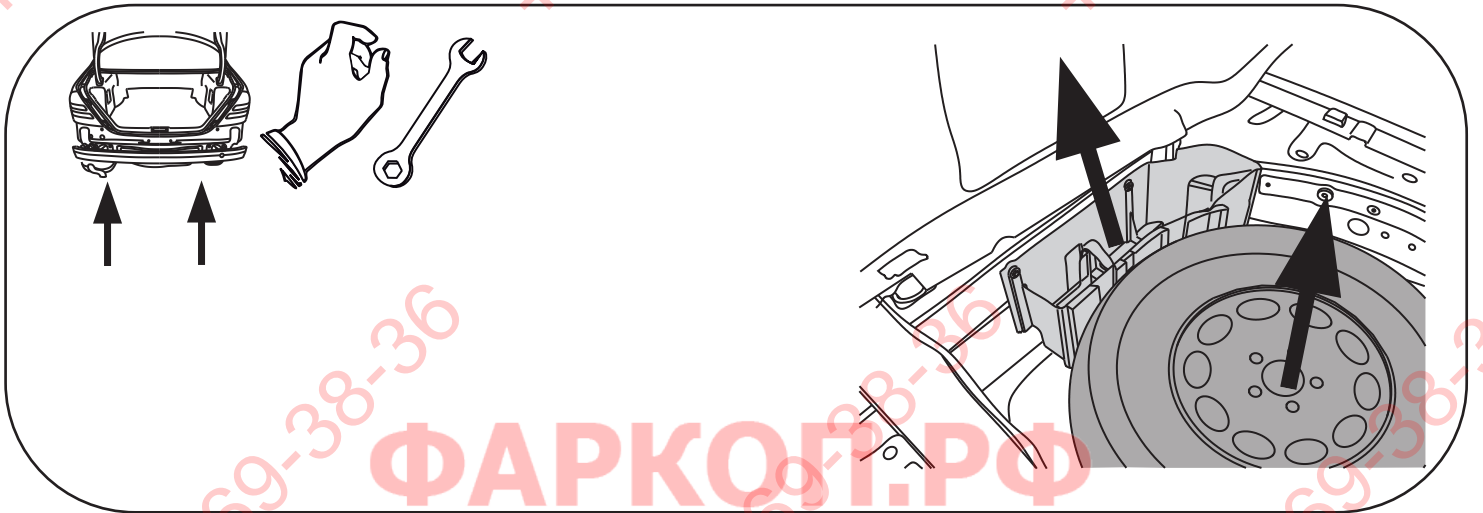
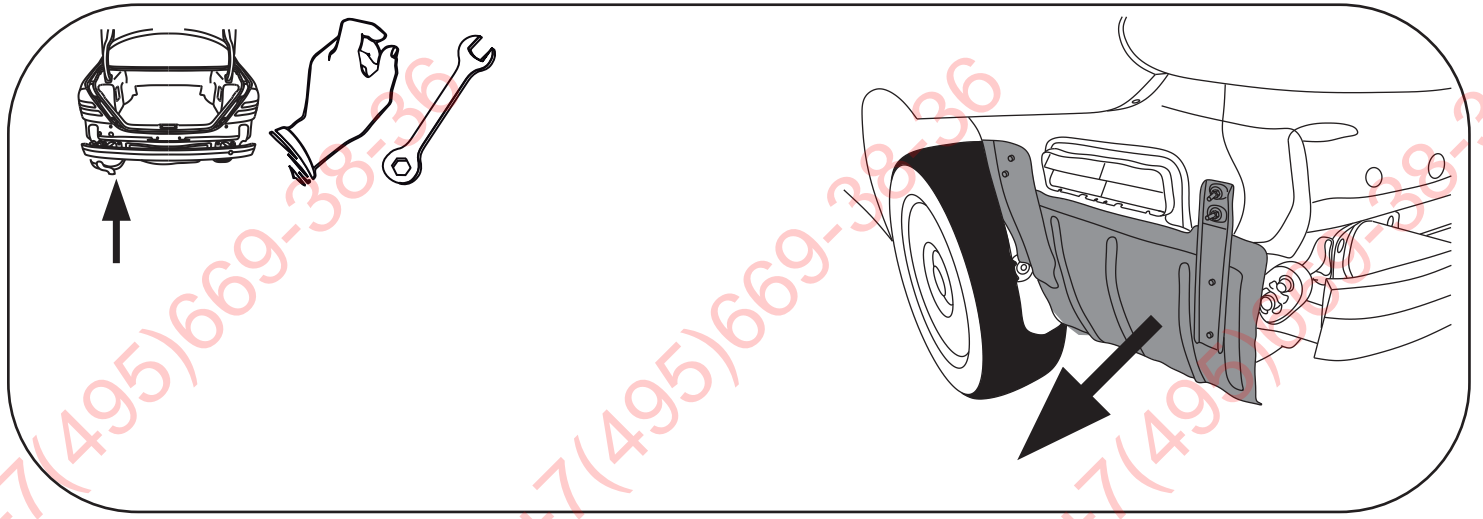

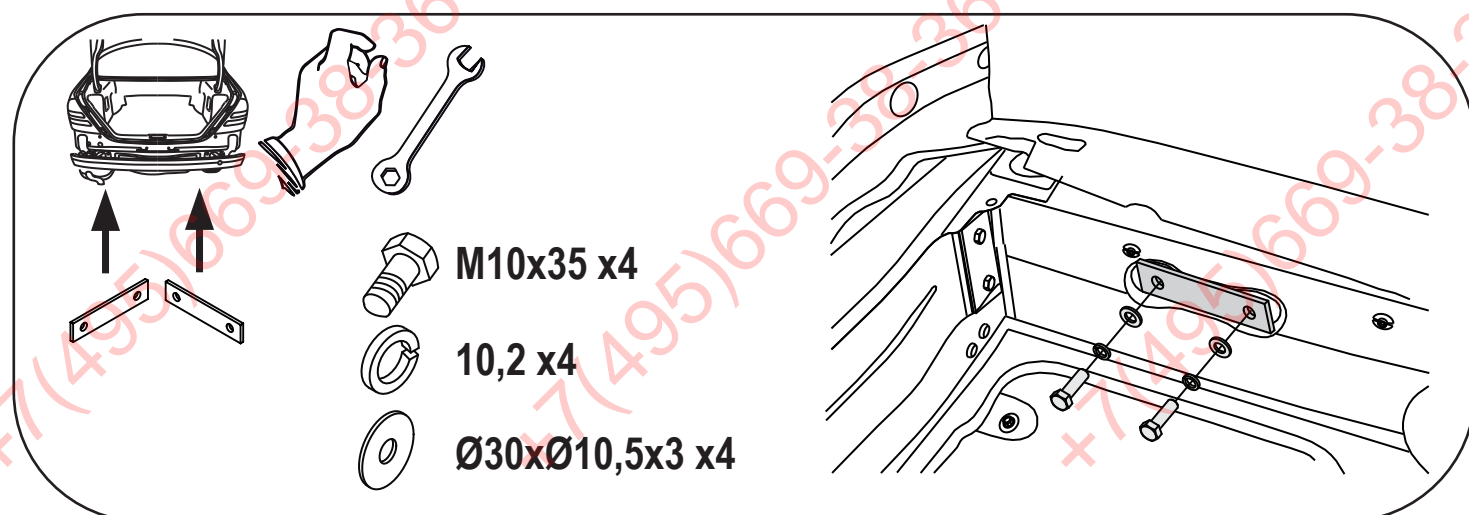
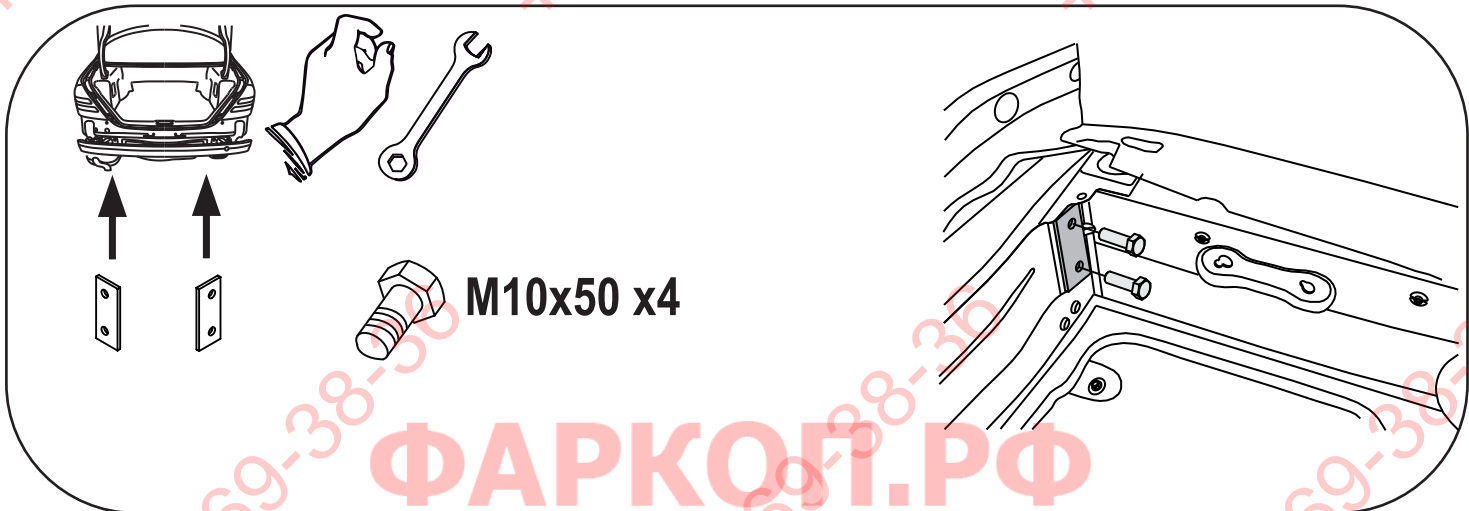
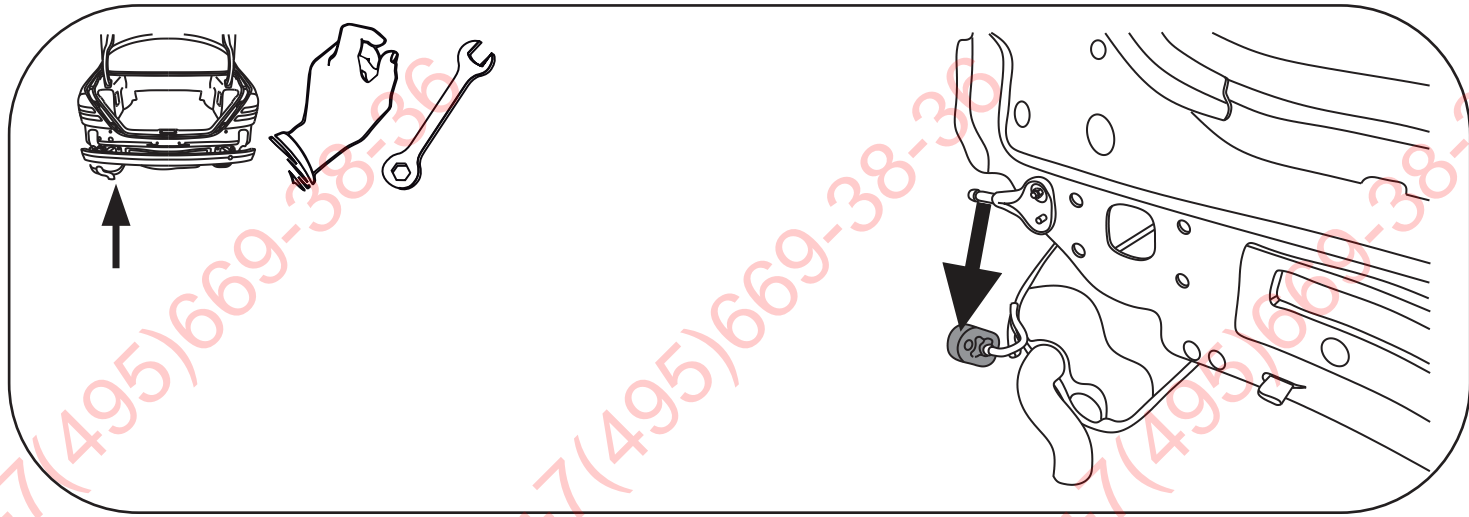

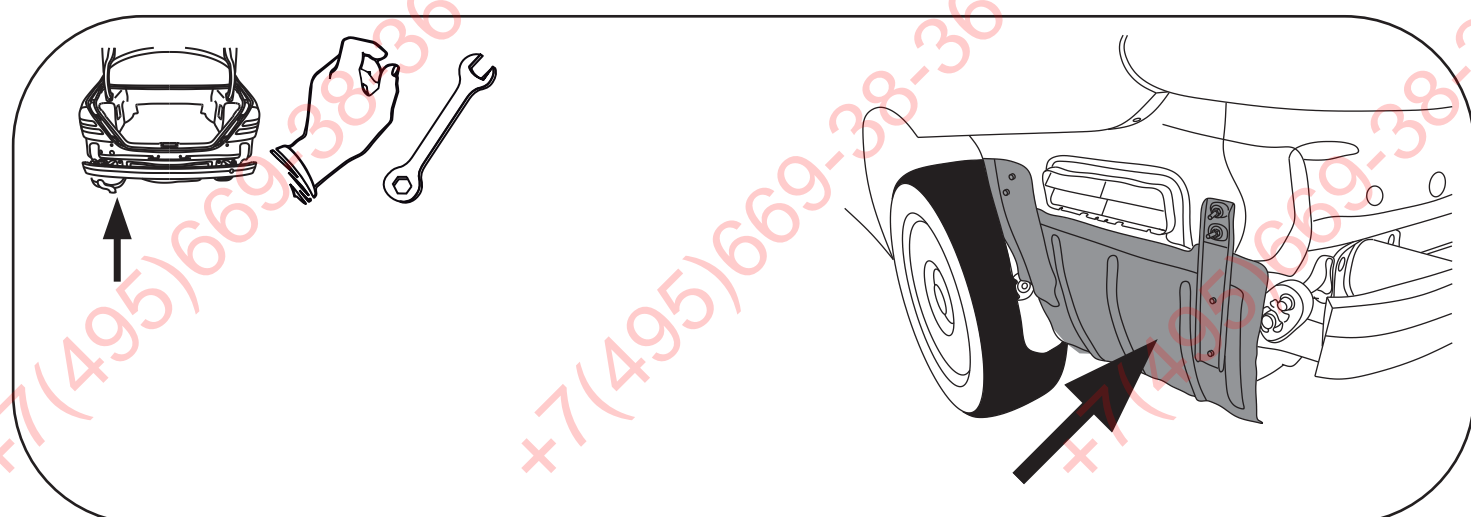
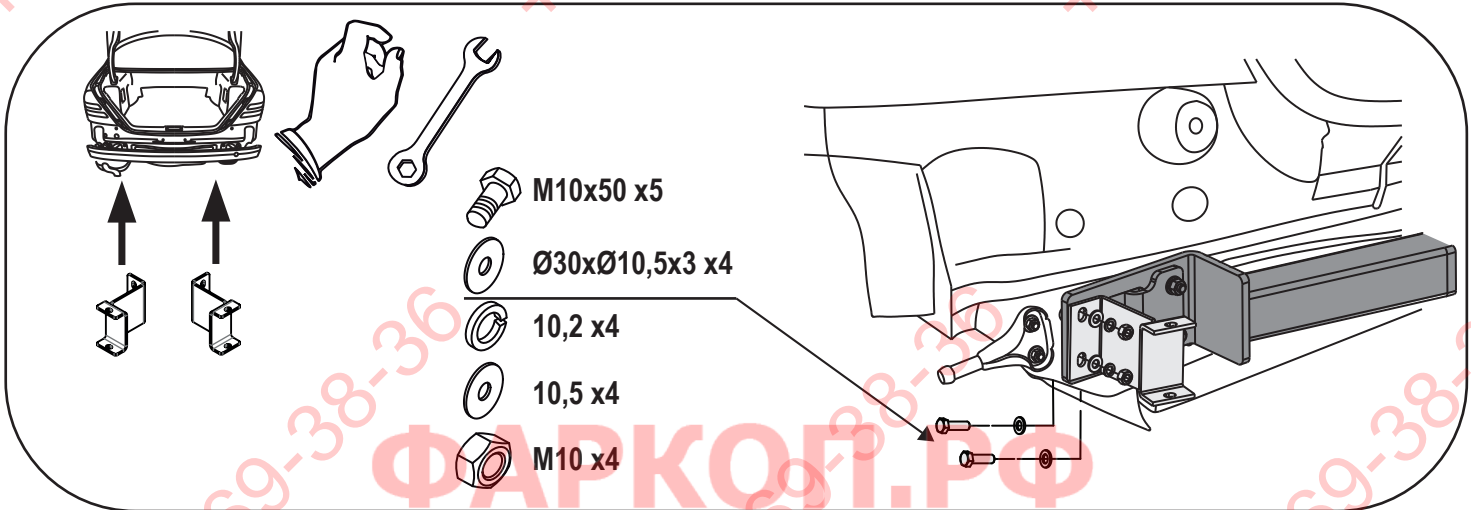
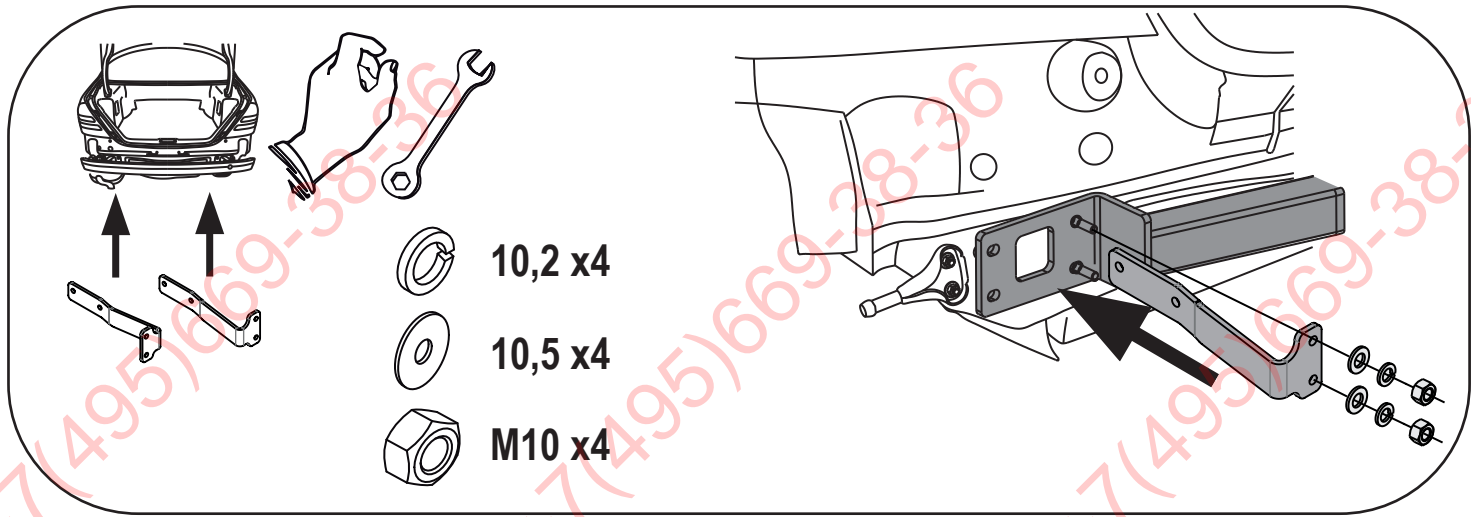

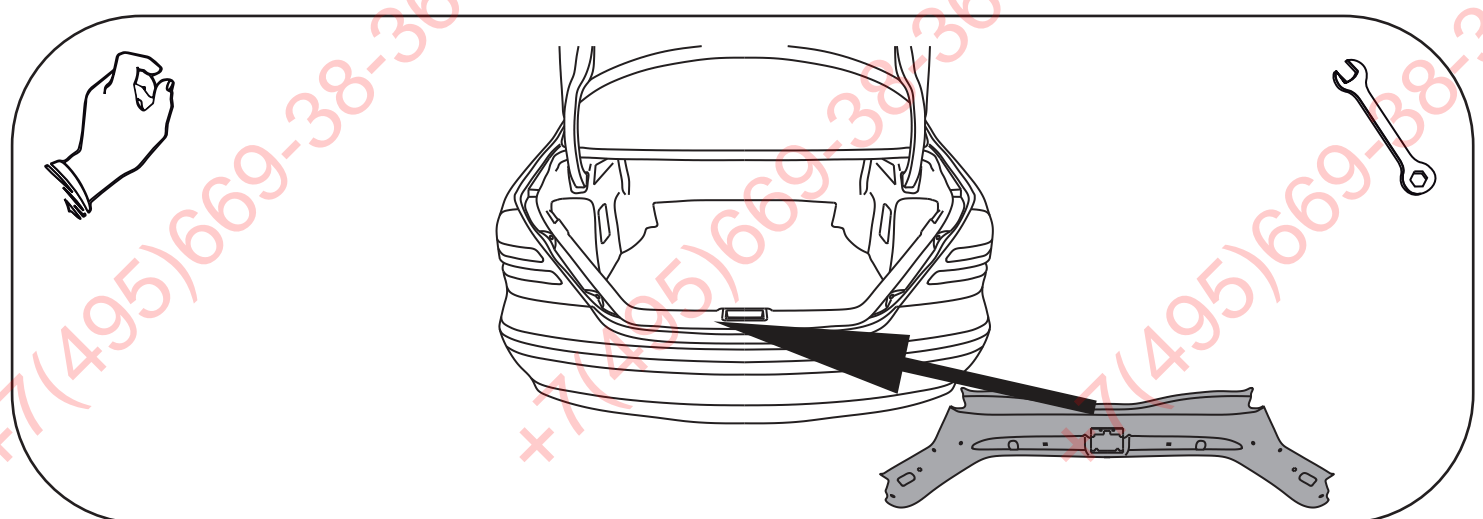
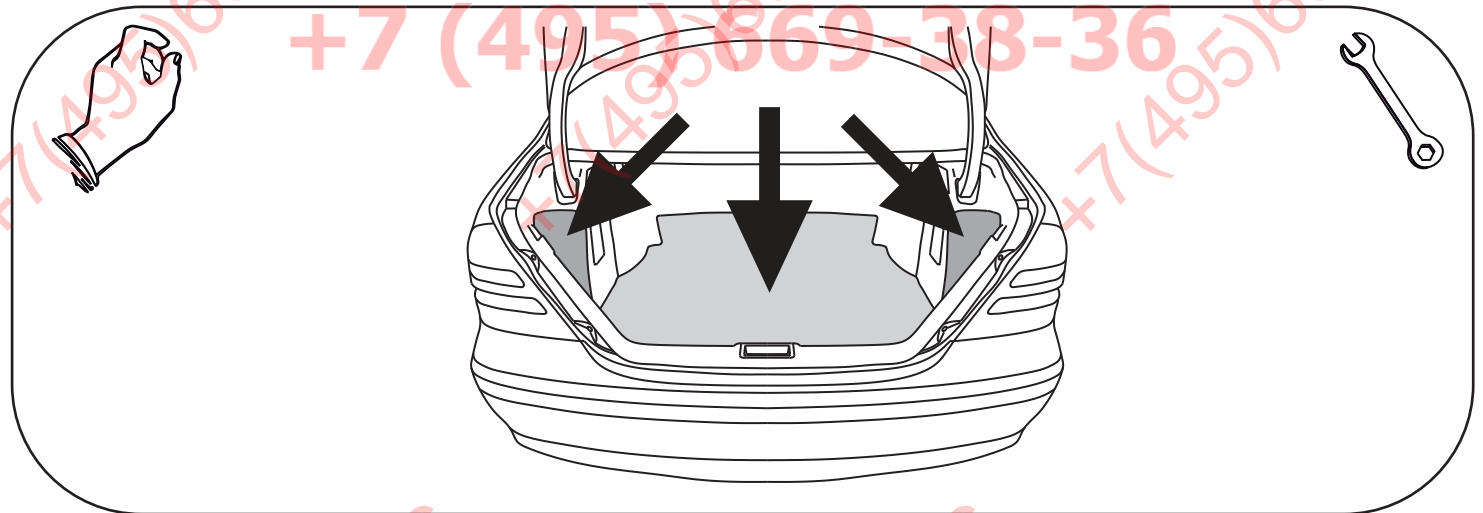
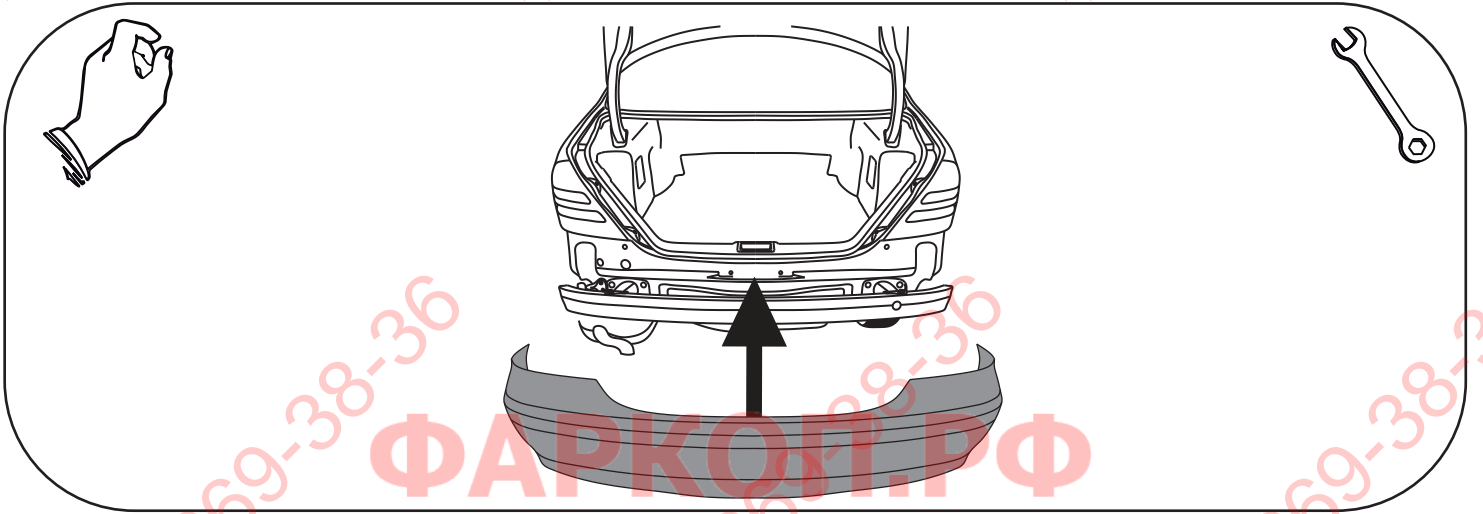
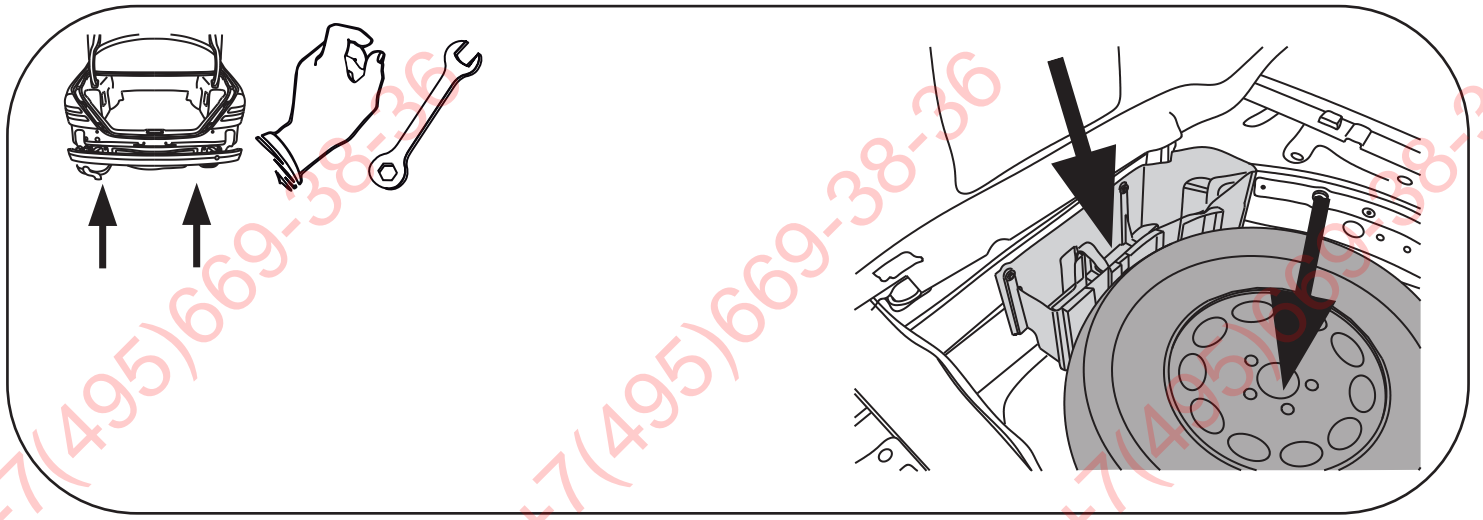

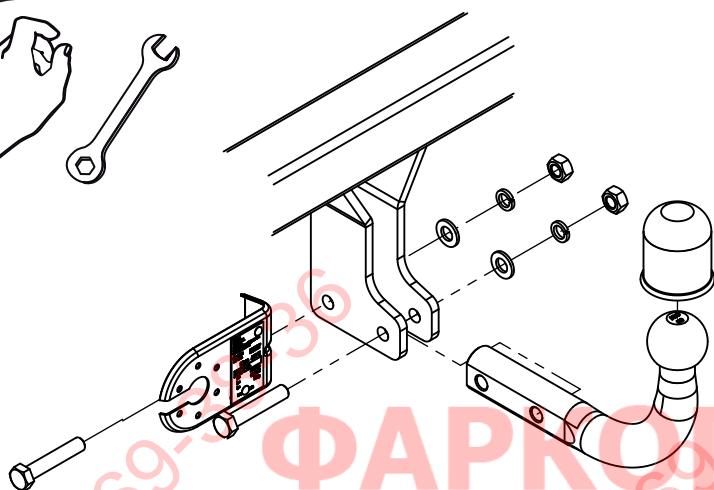
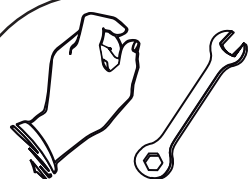
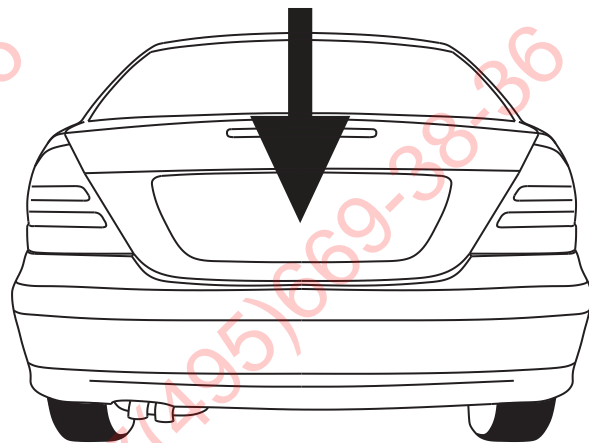

M12x70 x2



12,2 x2



13 x2



M12 x2

+7 (495) 669-38-36