



PEUGEOT 206

04/2003-2009
2009-

PEUGEOT 206+

Cat. No. **P/023**

e20

e20*94/20*0724*00

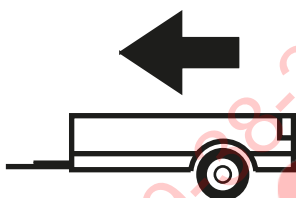

1100kg

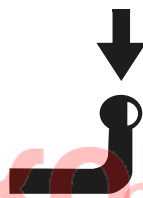

50kg

D = 6,39kN

D (kN) =



MAX kg

x

MAX kg

x 0,00981



MAX kg

+

MAX kg



IMIOLA HAK-POL

96-111 KOWIESY, CHOJNATA 23A, POLAND

Tel. + 48 46 831 73 31, fax +48 831 74 29

e-mail: office@imiola.pl, www.imiola.pl

PRZEKRÓJ A-A

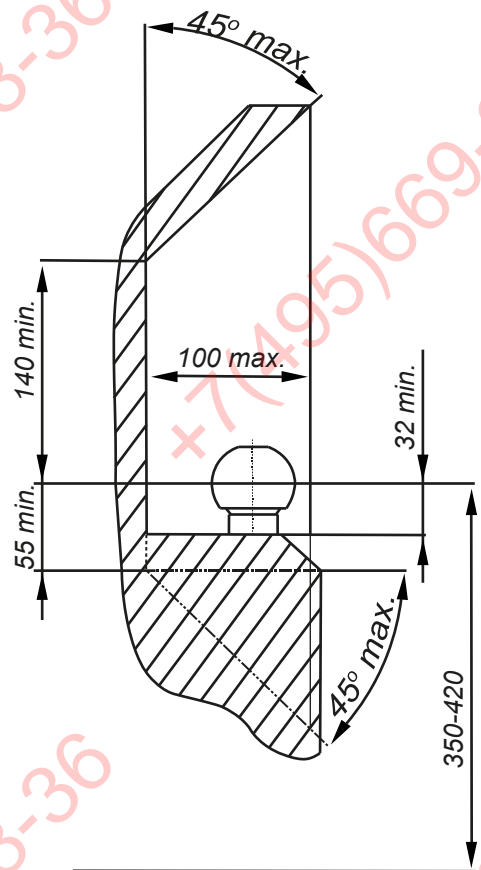
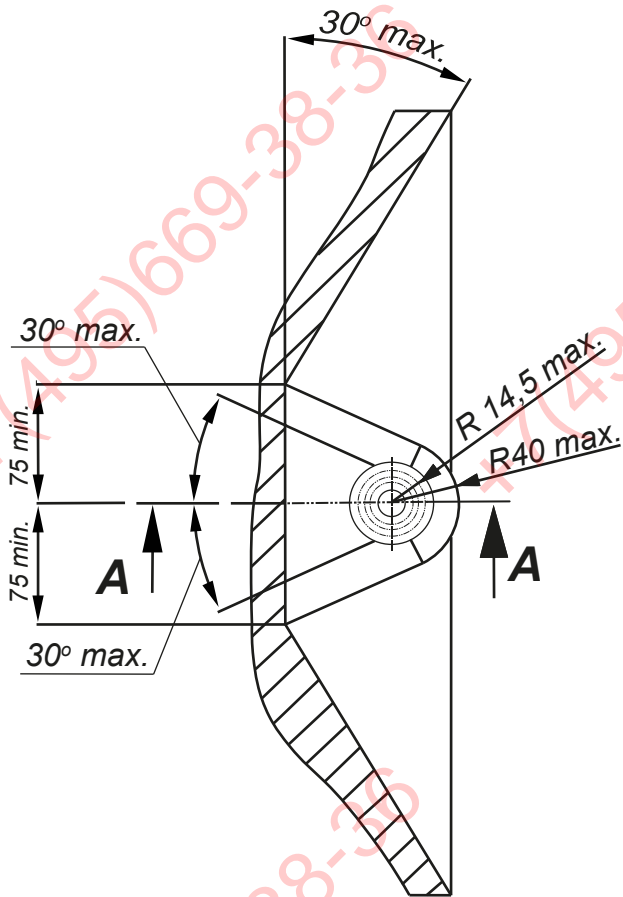

ФАРКОЛ.РФ

PL Należy zagwarantować przestrzeń swobodną według załącznika VII, rysunek 25a/b Regulaminu EKG ONZ 55.01 przy dopuszczalnym ciężarze całkowitym pojazdu.

F L'espace libre doit être garanti conformément à l'annexe VII, illustration de la réglementation 55.01 CE pour un poids total en charge autorisé du véhicule.

GB The clearance specified in appendix VII, diagram 25a/b of Regulation No. 55.01 UN EU must be guaranteed at laden weight of the vehicle.

D Der Freiraum nach Anhang VII, Abbildung 25a/b der Vorschriften 55.01 EG ist zu gew 25a/bahrleisten bei zulässigem Gesamtgewicht des Fahrzeuges.



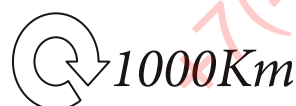

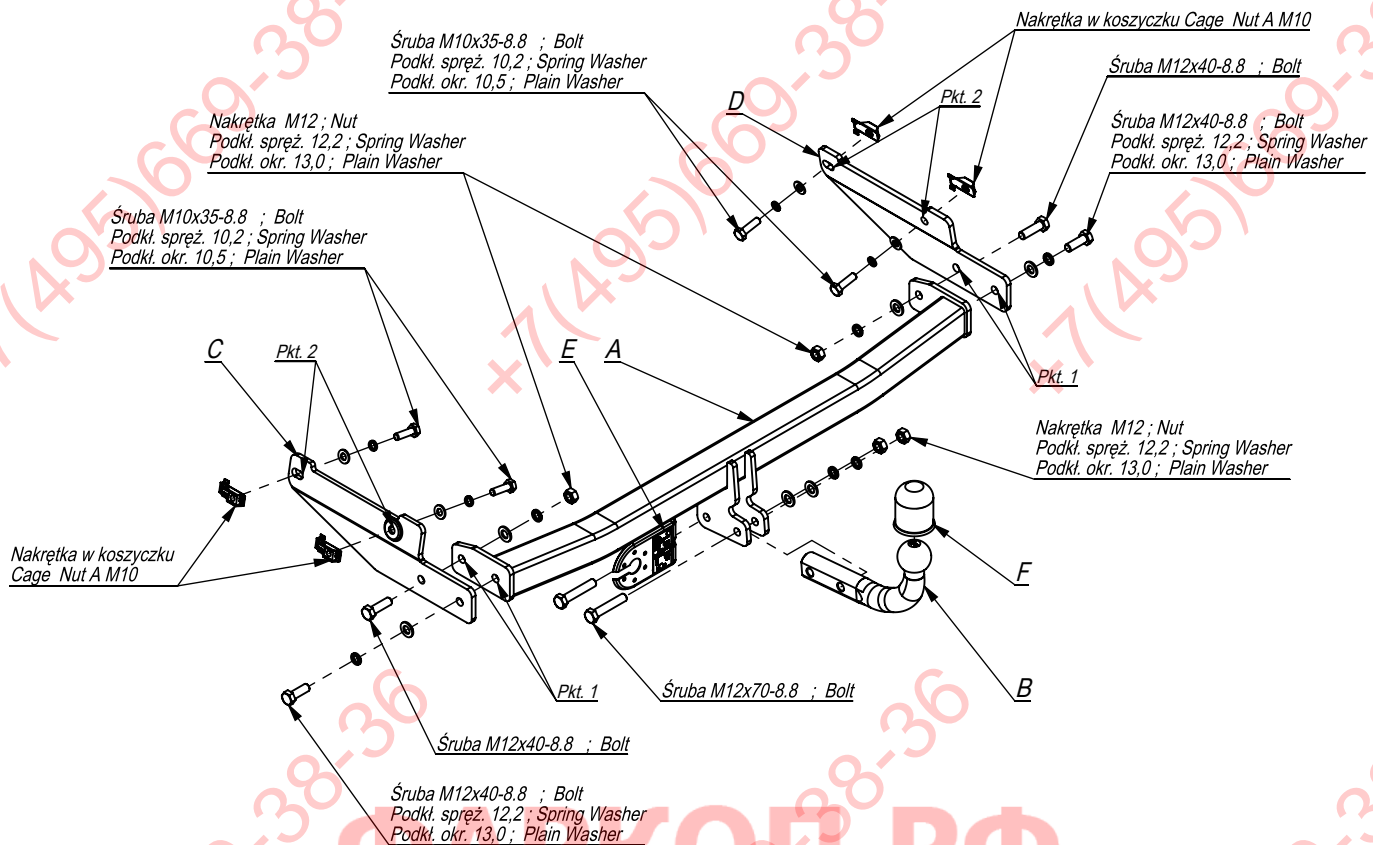





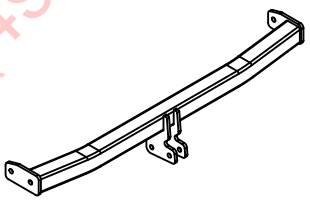
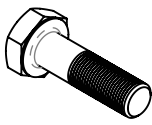
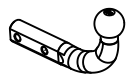

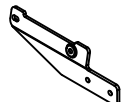
Moment skrczący dla śrub i nakrętek (8.8) Torgue settings for nuts and bolts (8.8)	
M8	25Nm
M10	55Nm
M12	85Nm
M14	135Nm
M16	195Nm

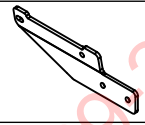

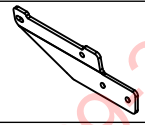

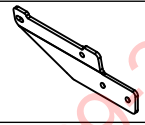
ФАРКОЛ.РФ

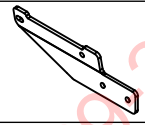
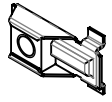
+7 (495) 669-38-36

	A	x1		M12x70	2
	B	x1		M12	4
	C	x1		13	6
	D	x1		10,5	4
	E	x1		12,2	6
	E	x1		10,2	4
	E	x1		M10	4
	F	x1			

Nakrętka w koszyczku Cage Nut A M10

Śruba M12x40-8.8 ; Bolt

Śruba M12x40-8.8 ; Bolt
Podkł. spręż. 12,2 ; Spring Washer
Podkł. okr. 13,0 ; Plain Washer

Nakrętka M12 ; Nut
Podkł. spręż. 12,2 ; Spring Washer
Podkł. okr. 13,0 ; Plain Washer

Śruba M10x35-8.8 ; Bolt
Podkł. spręż. 10,2 ; Spring Washer
Podkł. okr. 10,5 ; Plain Washer

Nakrętka M12 ; Nut
Podkł. spręż. 12,2 ; Spring Washer
Podkł. okr. 13,0 ; Plain Washer

Śruba M10x35-8.8 ; Bolt
Podkł. spręż. 10,2 ; Spring Washer
Podkł. okr. 10,5 ; Plain Washer

Śruba M12x70-8.8 ; Bolt

Śruba M12x40-8.8 ; Bolt
Podkł. spręż. 12,2 ; Spring Washer
Podkł. okr. 13,0 ; Plain Washer

Śruba M12x40-8.8 ; Bolt
Podkł. spręż. 12,2 ; Spring Washer
Podkł. okr. 13,0 ; Plain Washer

Nakrętka w koszyczku
Cage Nut A M10

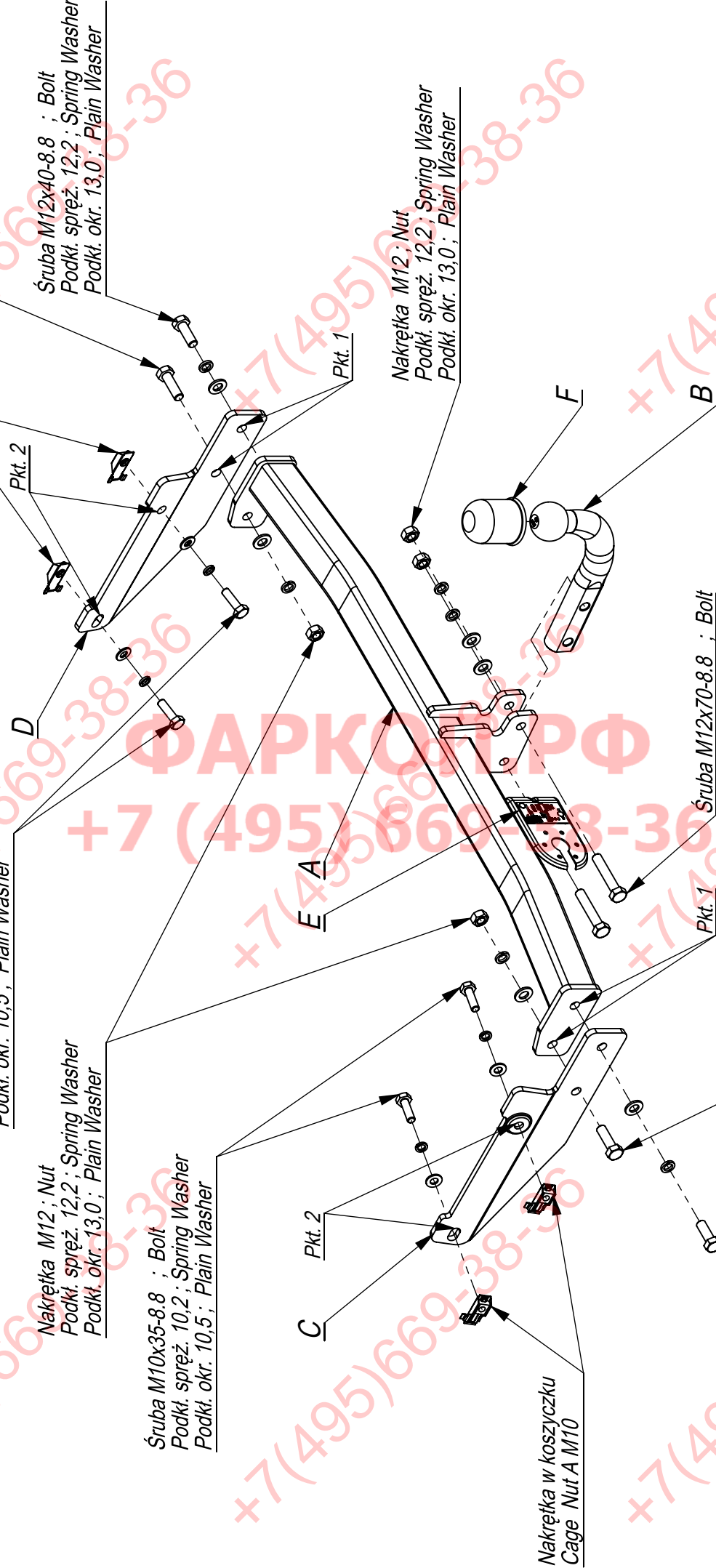

96-111 Kowiesy, Chojnata 23 A
tel. +48 46 831 73 31

Nr katalogowy
P/023

Marka
Peugeot 206

od 2003 ->

- Udzielić technologiczne otwory na bokach podłużnic.
- W otwory te włożyć specjalne wkładki z nakrętkami M10.
- Elementy haka C i D przykręcić lekko do podłużnic śrubami M10x35 8.8 (pkt 2).
- Do elementów haka C i D przykręcić belkę haka A śrubami M12x40 8.8 (pkt 1).
- Przykręcić kulę i blachę gniazda elektrycznego.
- Dokręcić wszystkie śruby z momentem wg tabeli.
- Podłączyć instalację elektryczną.

- The technological holes on the sides of the metal clamps make permeable.
- Insert the cage nuts M10 in these holes.
- Screw slightly the elements C and D to the metal clamps with bolts M10x35 8.8 (point 2).
- Screw slightly the main bar A to the elements C and D with bolts M12x40 8.8 (point 1).
- Fix the ball and electric plate.
- Tighten all the bolts according to the torque setting- see the table.
- Connect the electric wires.

- Déboucher les ouvertures sur les ancs des longerons.
- Insérer les languettes spéciales avec les écrous M10 dans ces ouvertures.
- Visser légèrement les éléments C et D aux longerons avec les boulons M10x35 8.8 (point 2).
- Visser la traverse de crochet A aux éléments C et D de crochet par les boulons M12x40 8.8 (point 1),
- Visser la boule et tôle de la prise électrique.
- Serrer tous les boulons avec un couple de serrage selon tableau.
- Raccorder le circuit électrique.

- Die vom Werk aus vorhandenen auf den Längsträgerseiten Öffnungen durchlässig machen.
- In diese Öffnungen die speziellen Einlagen mit den Muttern M10 einlegen.
- Die Tragteile C und D an die Längsträger mit den Schrauben M10x35 8.8 (Punkt 2) locker anschrauben.
- An die Tragteile C und D den Querbalken A mit den Schrauben M12x40 8.8 (Punkt 1) anschrauben.
- Die Kugel und die Steckdosenhalterung anschrauben.
- Die Elektroinstallation anschließen.
- Alle Schrauben mit dem in der Tabelle angegebenen Drehmoment festziehen.

- Limpiar los orificios en los largueros.
- Inserte la Cuget Nut M10 en los largueros a través de las aberturas de fábrica.
- Fijar los elementos C y D a los largueros con tornillos M10x35 8.8 (punto 2).
- Apretar una barra el gancho de remolque A con los tornillos M12x40 8.8 (punto 1).
- Apretar todos los tornillos con el par según la tabla anterior.
- Apretar la bola y la placa de la toma eléctrica.
- Conectar la instalación eléctrica.

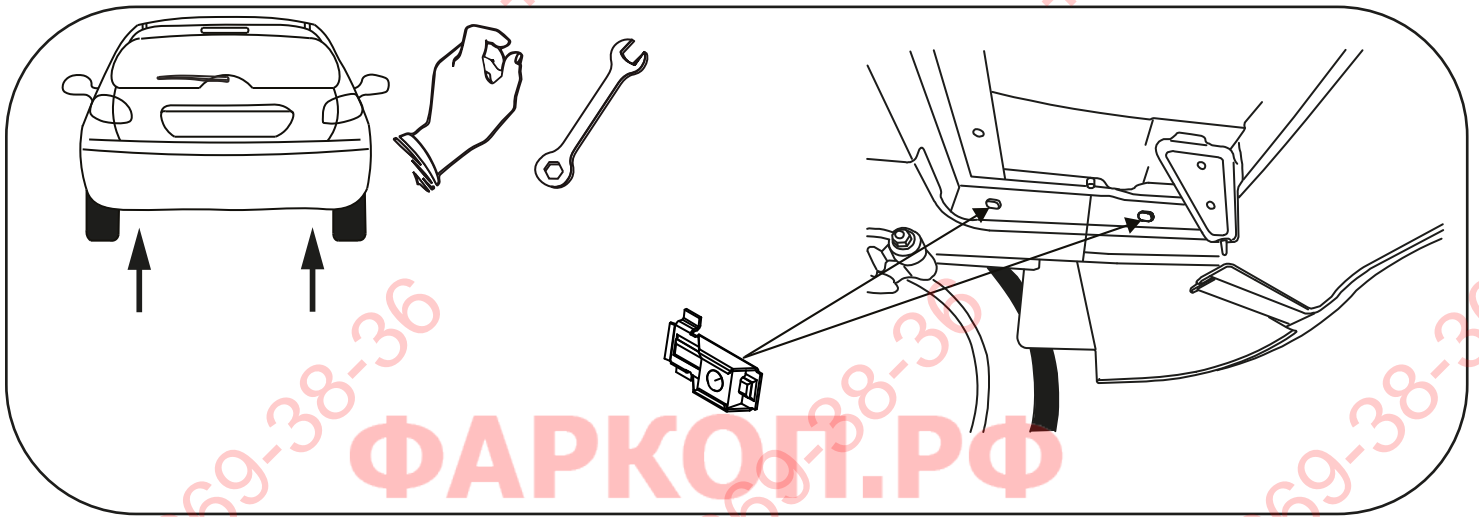
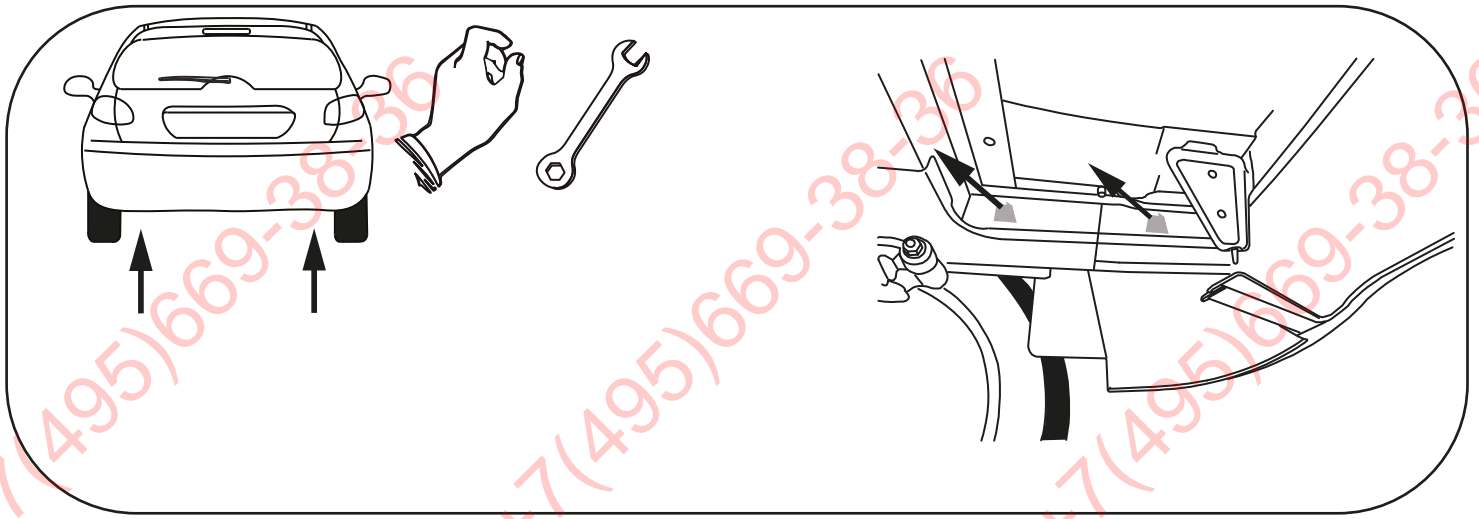

ФАРКОП.РФ

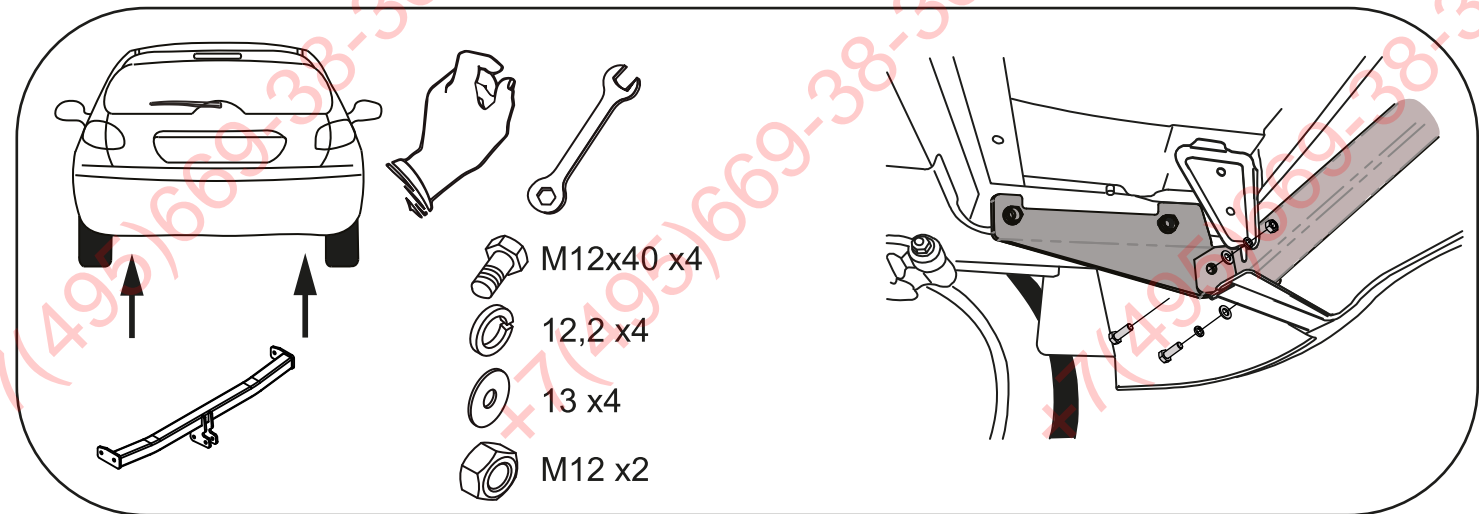
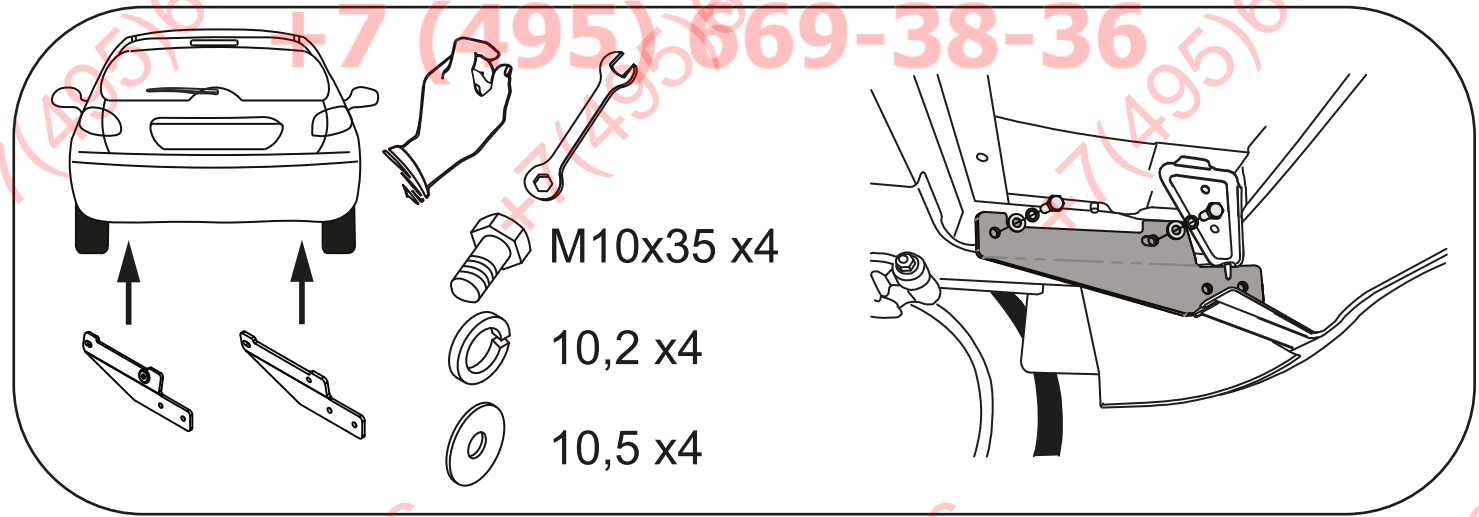

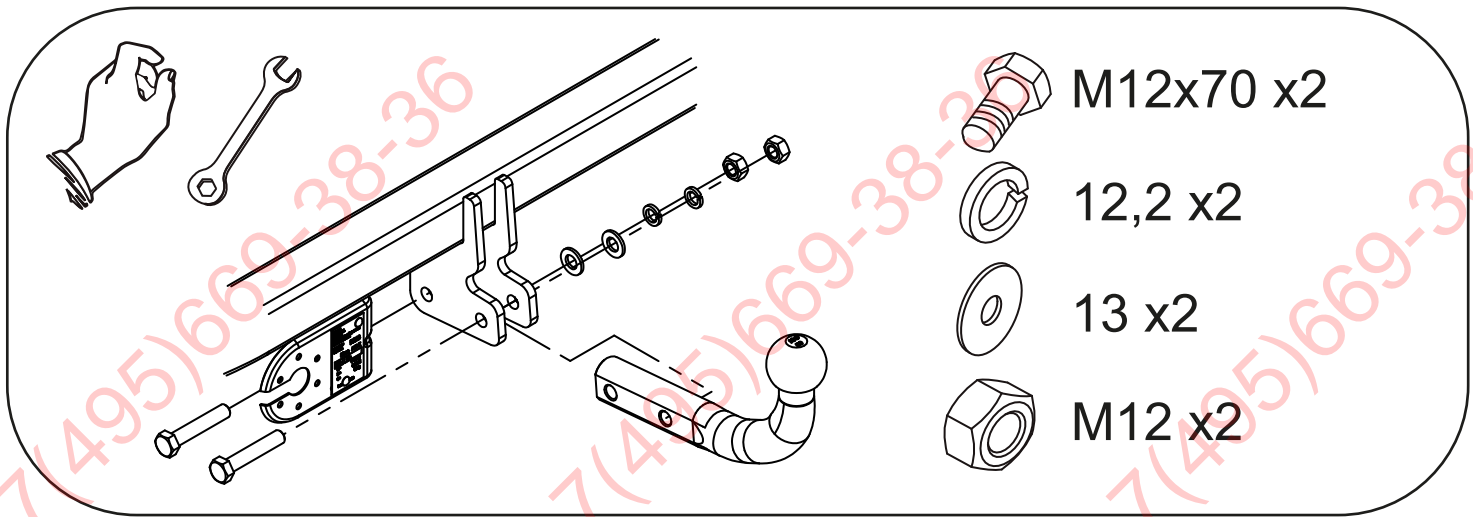

ФАРКОП.РФ

+7 (495) 669-38-36