

 DIN EN ISO 9001  
 Zertifikat Nr. 71 100 D 366

**Cat. No.R-078**
**DESTINATION**

Tow bar **R-078** for a **Renault Laguna (Grand Tour)** is designed for towing a trailer. This ball hook has a current certification of approval authorizing the product with **e20** certification sign.

**FITTING CONDITIONS**

Tow bar **R-078** can be used and operated in a car with proper technical conditions of body elements. Those parts cannot be mechanically damaged. The ball hook has to be installed and operated in a car according to this instruction. All bolts and nuts in ball hook have to be screwed down with proper torque (Mo). Torque values are given below:

M8	-	25 (Nm)	M12	-	85 (Nm)
M10	-	50 (Nm)	M16	-	200 (Nm)

**OPERATION CONDITIONS**

The tow bar **R-078** has a rating plate describing correct and safe loads of the hook:

Typ: <b>R-078</b> <b>A50-X</b> <b>e20 0154-00</b> D = 8,5 kN S = 75 kg R = 1500 kg	The tow bar for <b>Renault Laguna (Grand Tour)</b> Tow bar class ( compressing device ) Tow bar certification of approval number Theoretical related force working on a ball hook Max permissible vertical load of the hook ball Max permissible load of towing trailer
---	--

**D - force is calculated using the following formula:**

$$D = g \times \frac{T \times R}{T + R} \text{ kN}$$

T-technically permissible maximum mass in tonnes of the towing vehicle (also towing tractors) including, if necessary, the vertical load of a centrale axle trailer.  
 R-technically permissible maximum mass in tonnes of the full trailer with drawgal free to move in the vertical plane or of the semi-trailer.  
 g-acceleration due to gravity (assumed as 9,81 m/s<sup>2</sup>)

During operating individual elements of ball hook should be kept in a proper technical condition and protected from corrosion. The trailer must be linked with an elastic joint with proper durability ( cord, chain ) while towing. It is necessary to check periodically bolt joints during operating the ball hook. If screws are eased, it is necessary to screw them down.

**FITTING**

The tow bar **R-078** for **Renault Laguna (Grand Tour)** is made up of the following elements:

1. Tow bar mainframe	- 1 piece	11. Bolt M12x65	- 2 pieces
2. Tow ball	- 1 piece	12. Bolt M10x100	- 2 pieces
3. Electrical plate	- 1 piece	13. Flat washer 8,4	- 4 pieces
4. Right support	- 1 piece	14. Flat washer 10,5	- 2 pieces
5. Left support	- 1 piece	15. Flat washer 13,0	- 2 pieces
6. Cage Nut M8 (CH-005.01)	- 4 pieces	16. Spring washer 8,2	- 4 pieces
7. Special washer 40/ 10,5x2,5	- 2 pieces	17. Spring washer 10,2	- 2 pieces
8. Distance sleeve 17,3/ 12,5x65	- 2 pieces	18. Spring washer 12,2	- 6 pieces
9. Bolt M8x35	- 4 pieces	19. Nut M10	- 2 pieces
10. Bolt M12x35	- 4 pieces	20. Nut M12	- 6 pieces

Follow the general directions in order to fit **R-078** tow bar properly:

1. Rear bumper cutting or dismantling is **not required**.
2. In the bottom of the stripe find existing holes, than place (6) in the holes.
3. Dismantle plastic cover.
4. From the outside put (8) into the original holes of chassis elements before this remove hole plugs.
5. To so prepared chassis screw down (4) and (5) using (12), (7), (14), (17) and (19). Than using (9), (13) and (16) according to the drawing.
6. Place (1) between (5) and (6) and screw down using (10), (18) and (20).
7. Screw down the plastic cover.
8. Screw (2) into (1) using (11), (15), (18), (20), screwing (3) on the left side of (2) at the same time.
9. Check if all fixing bolts and nuts are screwed hard enough.

**Obeying this instruction assures correct montage and the tow bar operating in a Renault Laguna (Grand Tour).**

After assembling of the tow bar **R-078** you have to get entry in cars **registration book** in a quality control station.

**CAUTION:**

All mechanical damages of tow bar excludes its further exploitation. Damaged ball hook **cannot be repaired**. In case of braking the rules of montage or unproper usage manufacturer **do not take responsibility** for arised damages.

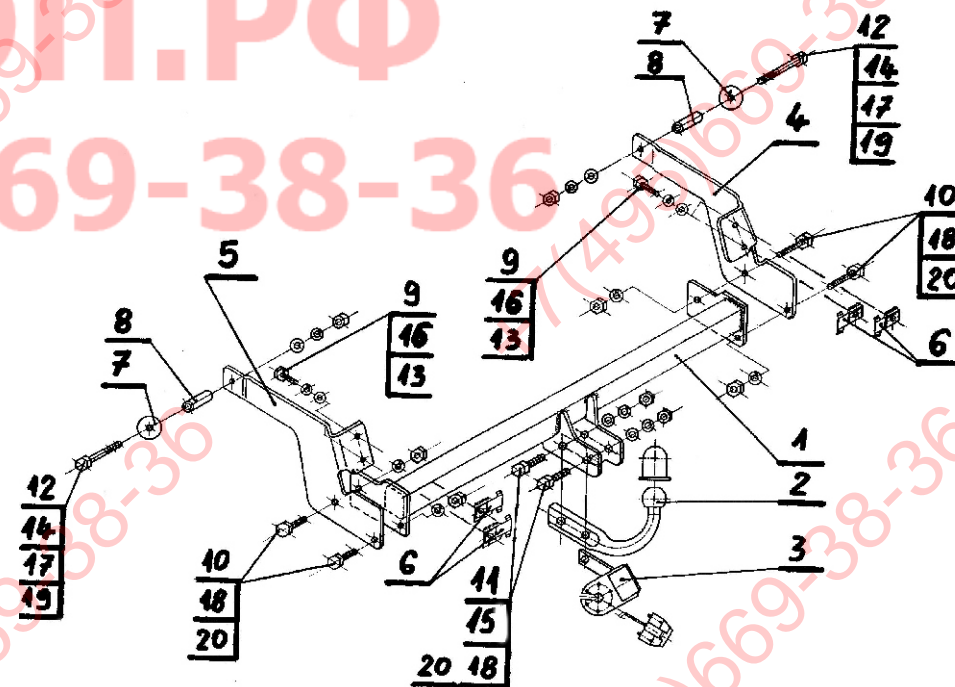
**MONTAGE DIAGRAM:**

**NOTE:**

Bunch of wires is not included (in total price).