



09/2005-12/2014

RENAULT CLIO III htb.

Cat. No. **R/033**

**e20**

e20\*94/20\*0446\*00

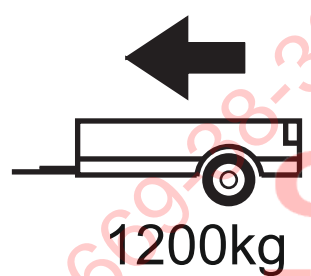

**D** = 7,00kN

**D (kN) =**



MAX kg x MAX kg

x 0,00981



MAX kg + MAX kg

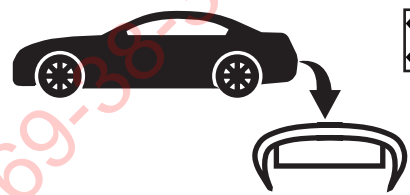

IMIOLA HAK-POL

96-111 KOWIESY, CHOJNATA 23A, POLAND

Tel. + 48 46 831 73 31, fax +48 831 74 29

e-mail: office@imiola.pl, www.imiola.pl

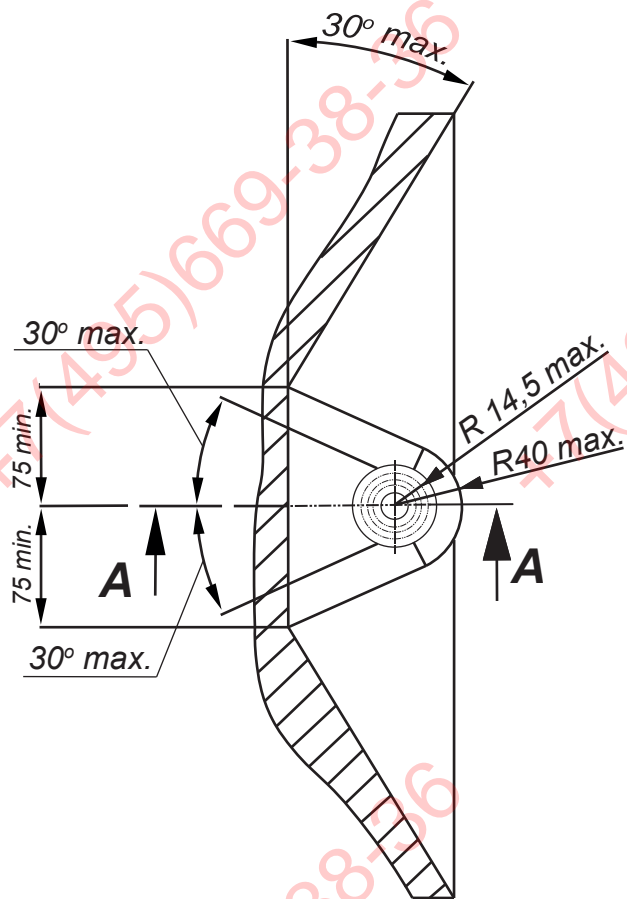

**PRZEKRÓJ A-A**

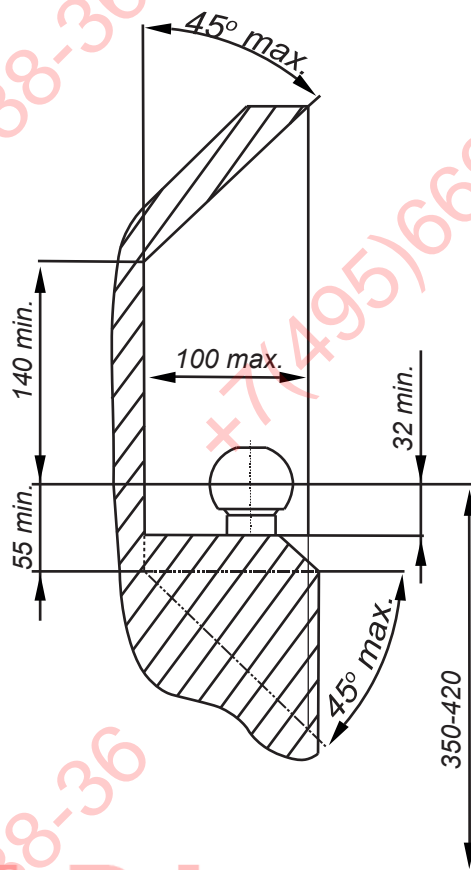

**ФАРКОГ.РФ**

**PL** Należy zagwarantować przestrzeń swobodną według załącznika VII, rysunek 25a/b Regulaminu EKG ONZ 55.01 przy dopuszczalnym ciężarze całkowitym pojazdu.

**F** L'espace libre doit être garanti conformément à l'annexe VII, illustration de la réglementation 55.01 CE pour un poids total en charge autorisé du véhicule.

**GB** The clearance specified in appendix VII, diagram 25a/b of Regulation No. 55.01 UN EU must be guaranteed at laden weight of the vehicle.

**D** Der Freiraum nach Anhang VII, Abbildung 25a/b der Vorschriften 55.01 EG ist zu gewährleisten bei zulässigem Gesamtgewicht des Fahrzeuges.

| Moment skręcający dla śrub i nakrętek (8.8)<br>Torgue settings for nuts and bolts (8.8) |       |
|---|-------|
| M8  | 25Nm  |
| M10   | 55Nm  |
| M12   | 85Nm  |
| M14   | 135Nm |
| M16   | 195Nm |



Śruba M10x100-8.8 ; Bolt  
Podkł. okr. 10,5 ; Plain Washer

Nakrętka M12 ; Nut  
Podkł. spręż. 12,2 ; Spring Washer  
Podkł. okr. 13,0 ; Plain Washer

Śruba M10x100-8.8 ; Bolt  
Podkł. okr. 10,5 ; Plain Washer







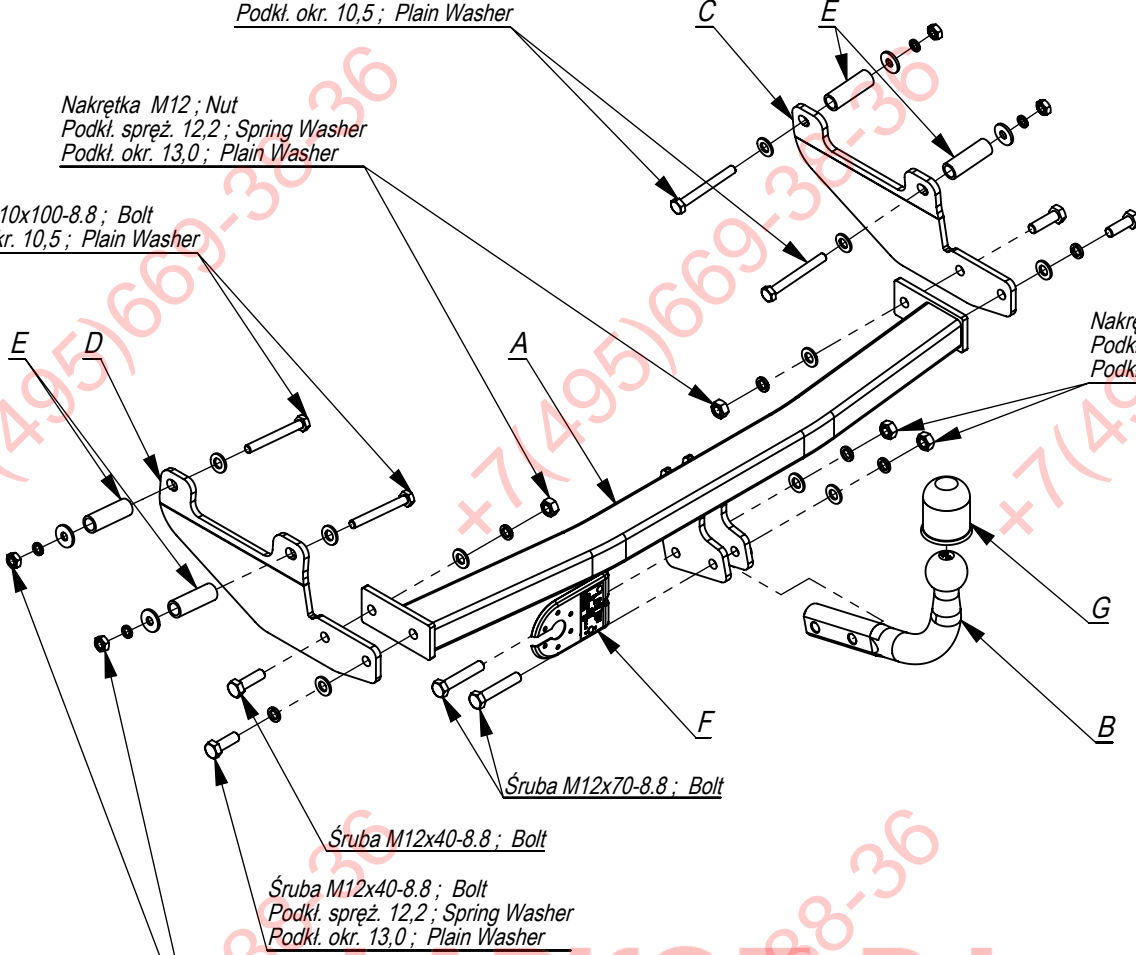
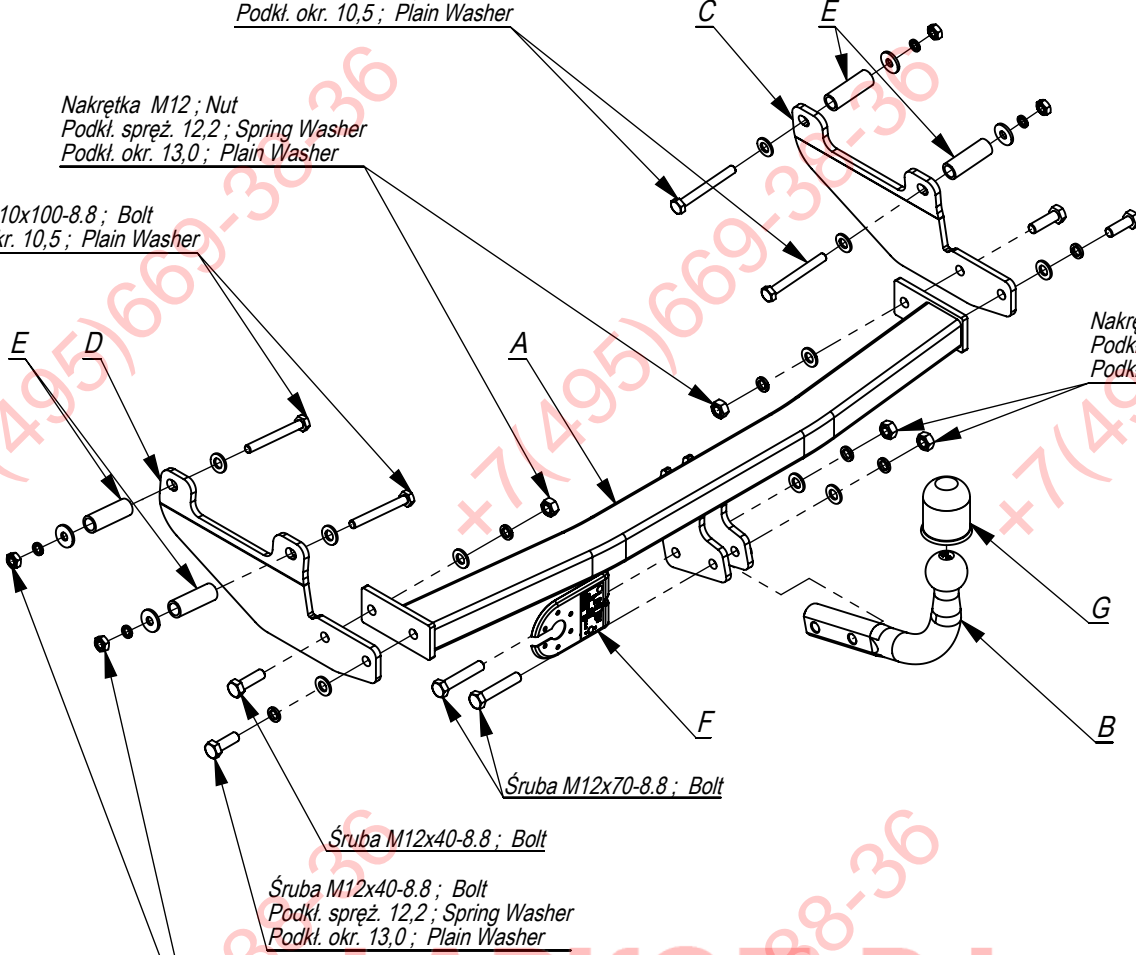
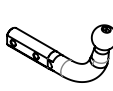
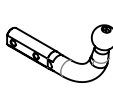
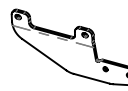
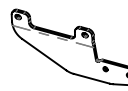

Nakrętka M12 ; Nut  
Podkł. spręż. 12,2 ; Spring Washer  
Podkł. okr. 13,0 ; Plain Washer

Śruba M12x70-8.8 ; Bolt

Śruba M12x40-8.8 ; Bolt

Śruba M12x40-8.8 ; Bolt  
Podkł. spręż. 12,2 ; Spring Washer  
Podkł. okr. 13,0 ; Plain Washer

Nakrętka M10 ; Nut  
Podkł. spręż. 10,2 ; Spring Washer  
Podkł. okr. pow. Ø30xØ10,5x3 ; Plain Washer

|   |   |    |   |             |   |
|---|---|----|---|-------------|---|
|   | A | x1 |   | M12x70      | 2 |
|  | B | x1 |  | M12x40      | 4 |
|  | C | x1 |  | M10x100     | 4 |
|  | D | x1 |  | M12         | 4 |
|  | E | x4 |  | M10         | 4 |
|  | F | x1 |  | Ø30xØ10,5x3 | 4 |
|  | G | x1 |  | 13          | 6 |
|   |   |    |   | 10,5        | 4 |
|   |   |    |   | 12,2        | 6 |
|   |   |    |   | 10,2        | 4 |

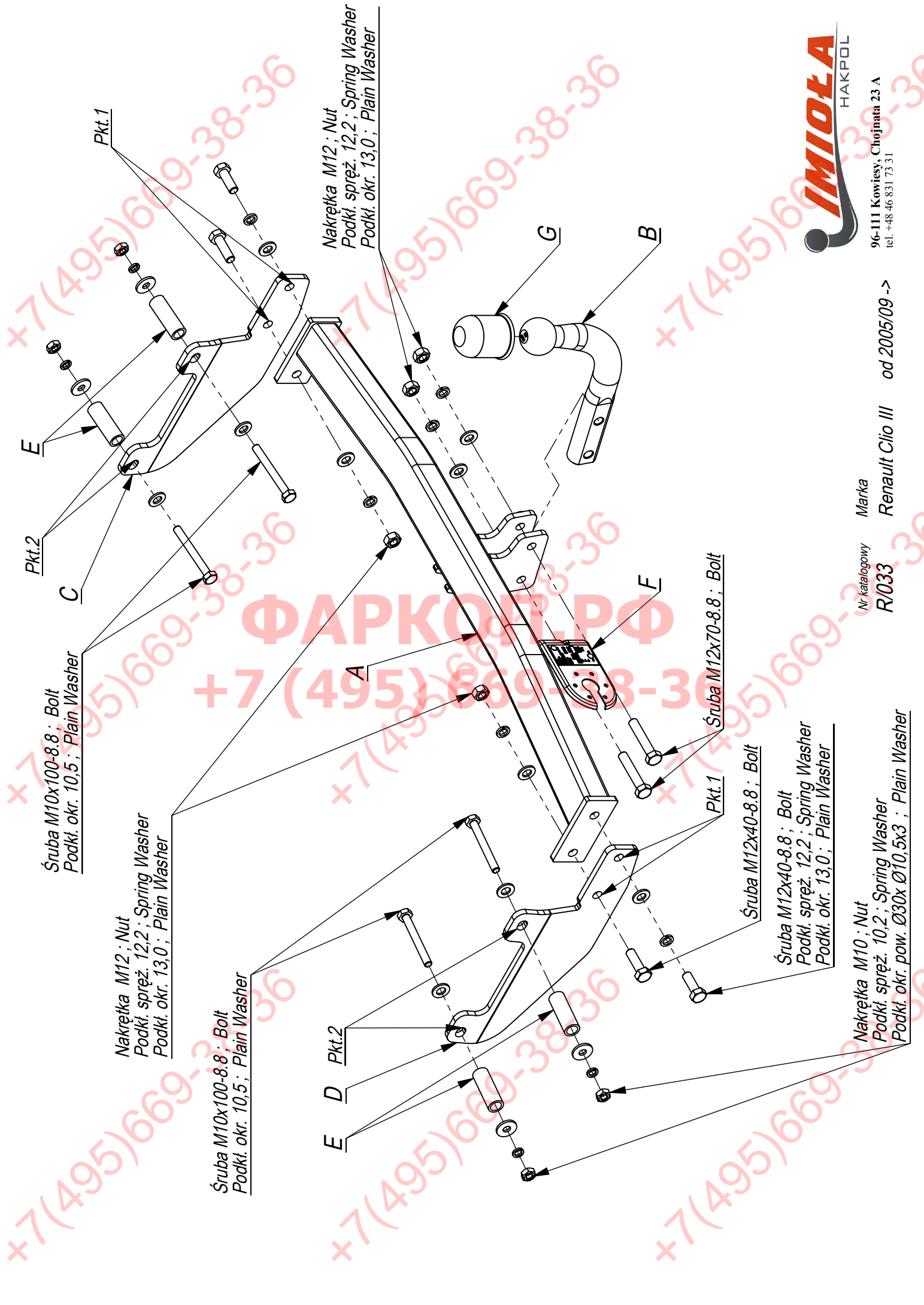

Śruba M10x100-8.8 ; Bolt  
Podkl. okr. 10,5 ; Plain Washer

Nakrętka M12 ; Nut  
Podkl. spręż. 12,2 ; Spring Washer  
Podkl. okr. 13,0 ; Plain Washer

Śruba M10x100-8.8 ; Bolt  
Podkl. okr. 10,5 ; Plain Washer

Nakrętka M12 ; Nut  
Podkl. spręż. 12,2 ; Spring Washer  
Podkl. okr. 13,0 ; Plain Washer

Śruba M12x70-8.8 ; Bolt

Śruba M12x40-8.8 ; Bolt

Śruba M12x40-8.8 ; Bolt  
Podkl. spręż. 12,2 ; Spring Washer  
Podkl. okr. 13,0 ; Plain Washer

Nakrętka M10 ; Nut  
Podkl. spręż. 10,2 ; Spring Washer  
Podkl. okr. pow. Ø30x Ø10,5x3 ; Plain Washer



96-111 Kowiesy, Chojnata 23 A  
tel. +48 46 831 73 31

Nr katalogowy R/033  
Marka Renault Clio III  
od 2005/09 ->

- Odkręcić koło zapasowe.
- Poluzować nadkole z prawej strony samochodu.
- W fabryczne otwory w podłużnicach od zewnętrznej strony włożyć tuleje dystansowe.
- Od wewnętrznej strony podłużnic przykręcić elementy haka C i D do podłużnic śrubami M10x90 8.8 (pkt 2)
- Do elementów haka C i D przykręcić belkę haka A śrubami M12x35 8.8 (pkt 1).
- Przykręcić kule i blachę gniazda elektrycznego śrubami M12x70 8.8 (pkt 3).
- Dokręcić wszystkie śruby z momentem wg tabeli.
- Dokręcić nadkole, przykręcić koło zapasowe.
- Podłączyć instalacje elektryczna.

- Unscrew the spare wheel.
- Loosen the wheel guard plate on the right of the car.
- Insert distance sleeves in the technological holes in the metal clamps from the outside.
- Screw the elements C and D to the metal clamps from the inside of the metal clamps with bolts M10x90 8.8 (point 2).
- Screw the main bar A to the elements C and D with bolts M12x35 8.8 (point 1).
- Fix the ball and electric plate with bolts M12x70 8.8 (point 3).
- Tighten all the bolts according to the torque setting- see the table.
- Screw the wheel guard plate and assemble the spare wheel.
- Connect the electric wires.

- Placer les douilles d'écartement dans les ouvertures de longerons,
- Visser les éléments d'attache C aux longerons par les
- boulons M10x100, 8.8 (point 1),
- Visser les éléments C et D à la traverse d'attache A par les
- boulons M12x35 8.8 (point 2),
- Serrer tous les boulons avec un couple de serrage selon tableau,
- Visser le crochet d'attelage et socle de prise électrique,
- Raccorder le circuit électrique.

- In die vom Werk aus vorhandenen in den Längsträgern Öffnungen, die Distanzhülsen D stecken.
- Die Tragteile C und D an die Längsträger mit den Schrauben M10x90 8.8 (Punkt 1) anschrauben.
- An die Tragteile C und D den Querbalken A mit den Schrauben M12x35 8.8 (Punkt 2) anschrauben.
- Alle Schrauben mit dem in der Tabelle angegebenen Drehmoment festziehen.
- Den Auspufftopf und den Thermoschutz einbauen.
- Das Ersatzrad anschrauben.
- Die Kugel und die Steckdosenhalterung anschrauben.
- Die Elektroinstallation anschließen.

- Desenroscar la rueda de repuesto.
- Introducir los casquillos de separación E con tornillos M10x90 8.8 (p. 2) en los orificios tecnológicos en los largueros.
- Atornillar la viga de la bola de remolque A con los elementos de la bola de remolque C y D, usando tornillos M12x35 8.8 (p. 1).
- Apretar la bola y la placa eléctrica con los tornillos M12x70 8.8.
- Apretar todos los tornillos con el par según la tabla anterior.
- Conectar la instalación eléctrica.
- Atornillar la rueda de repuesto.

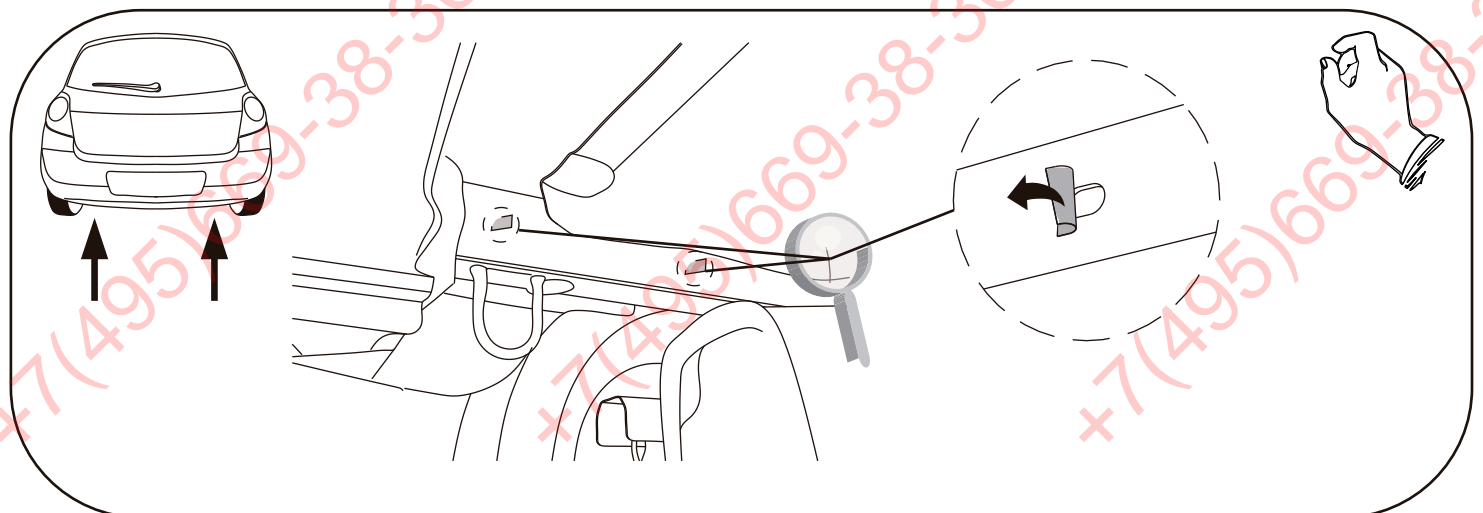
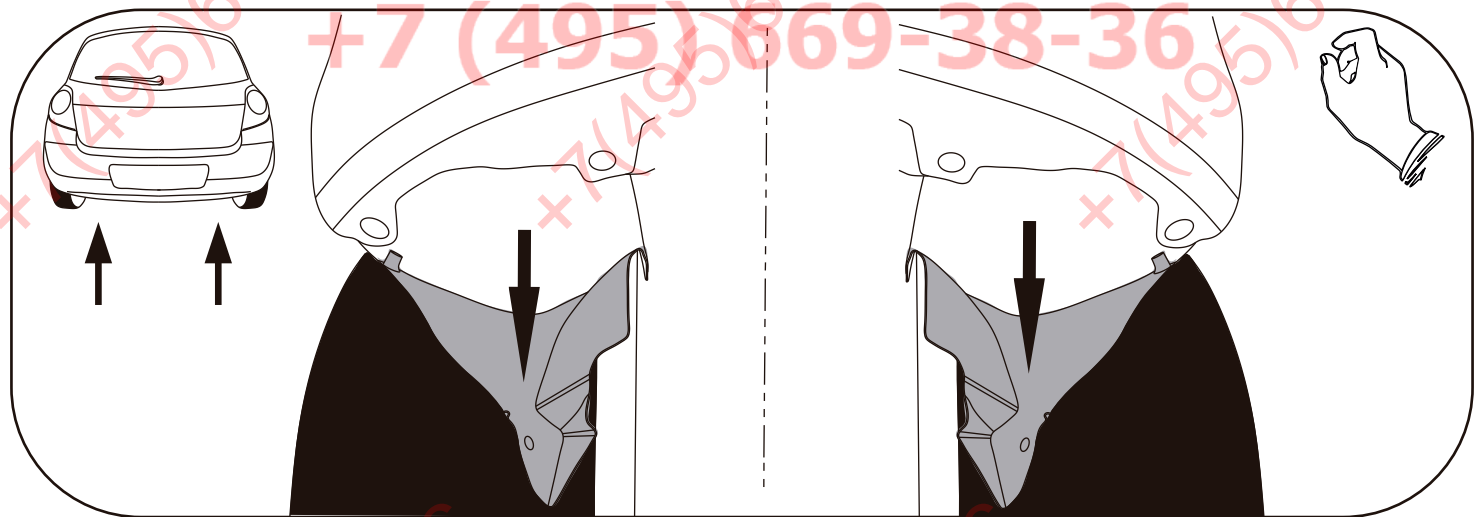
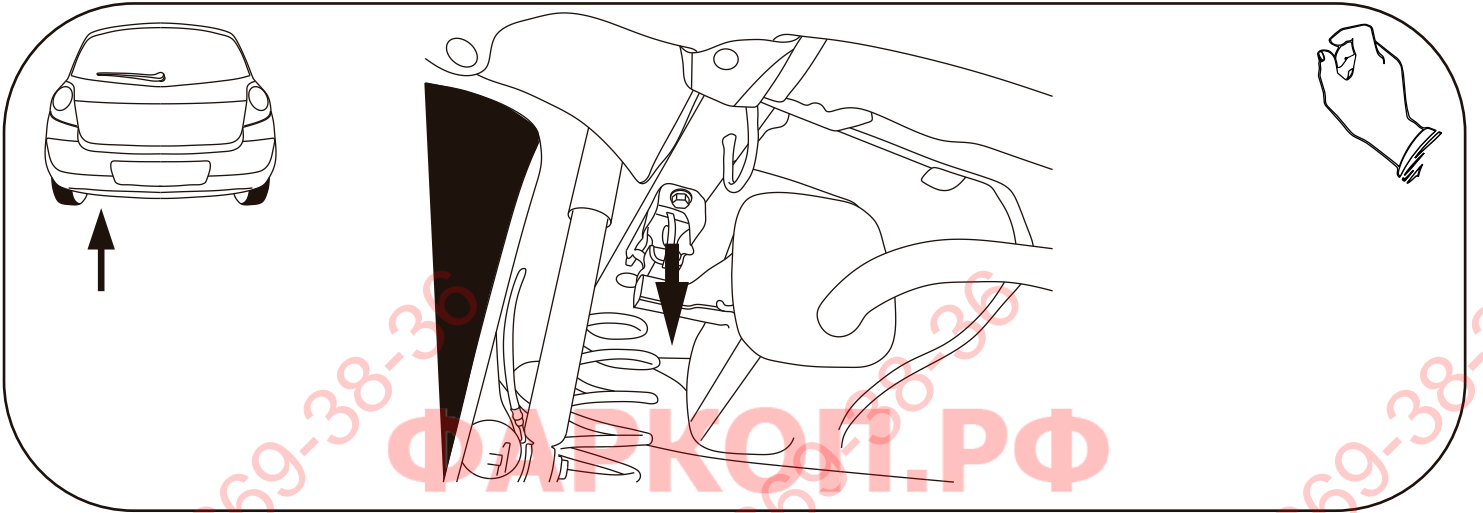
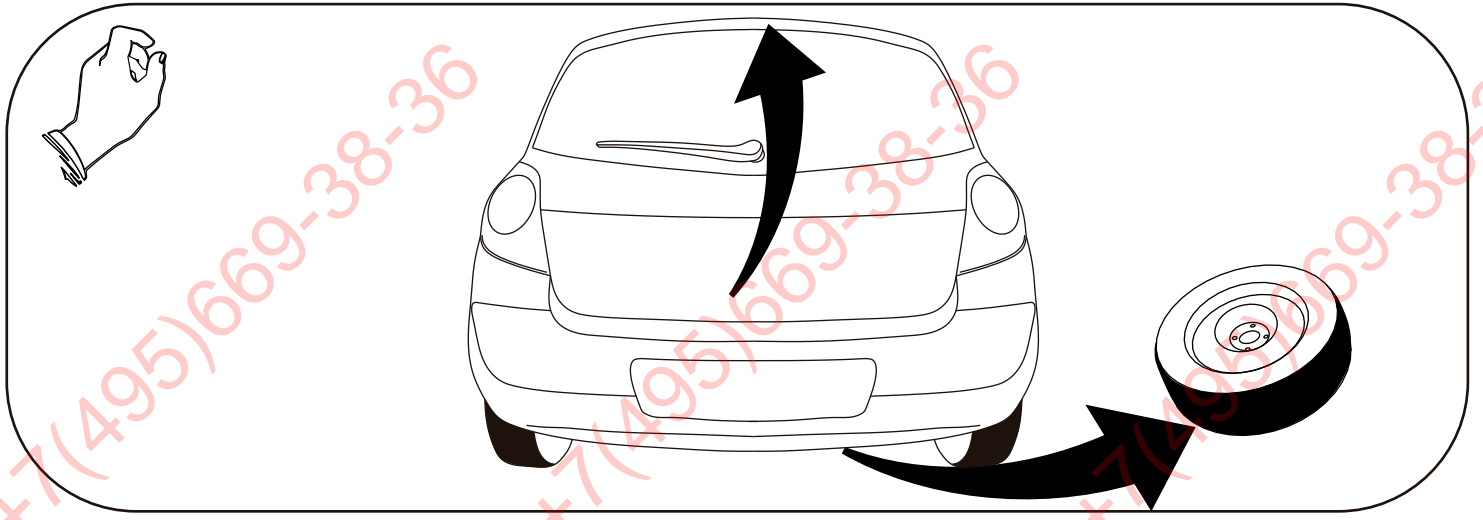

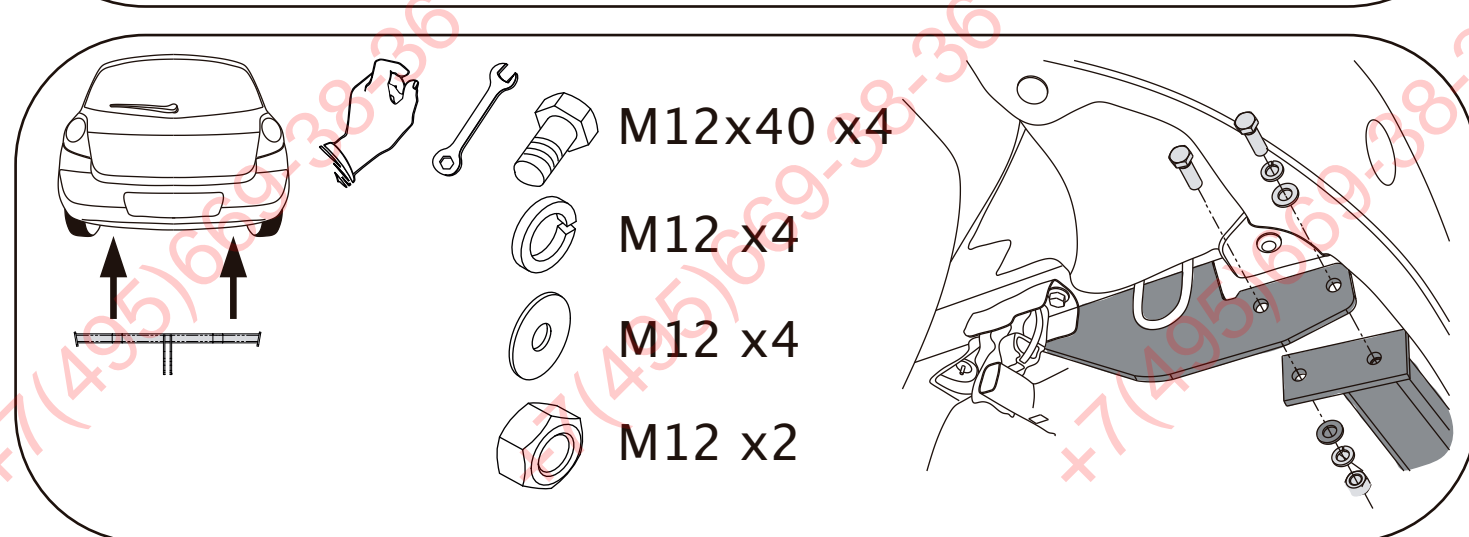
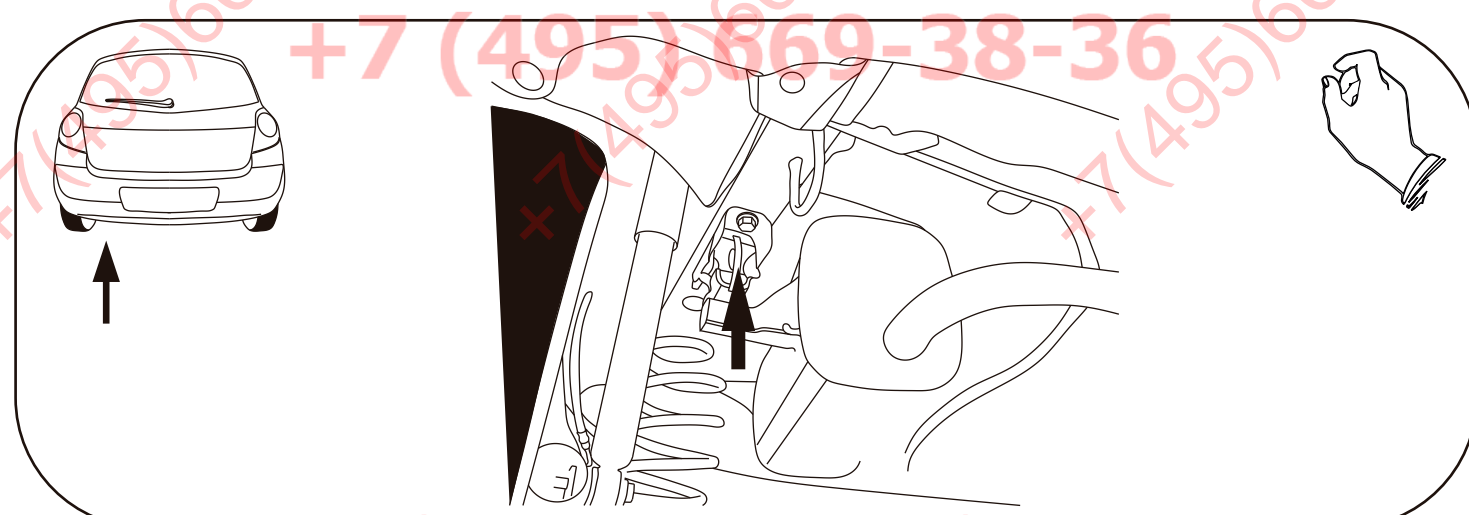
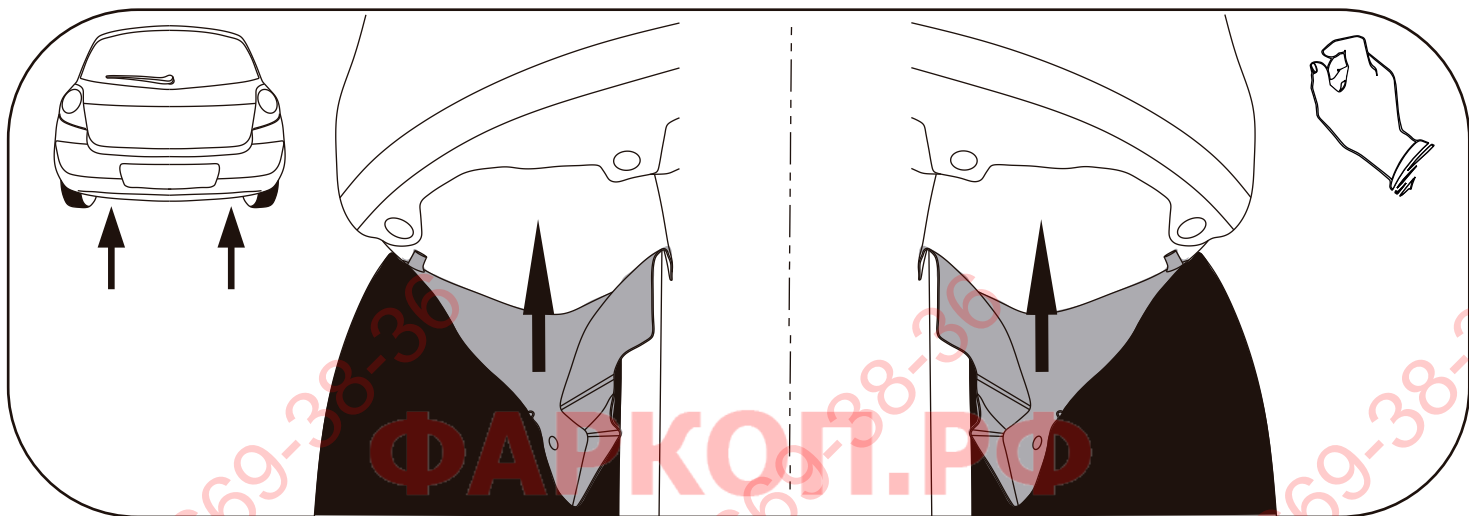
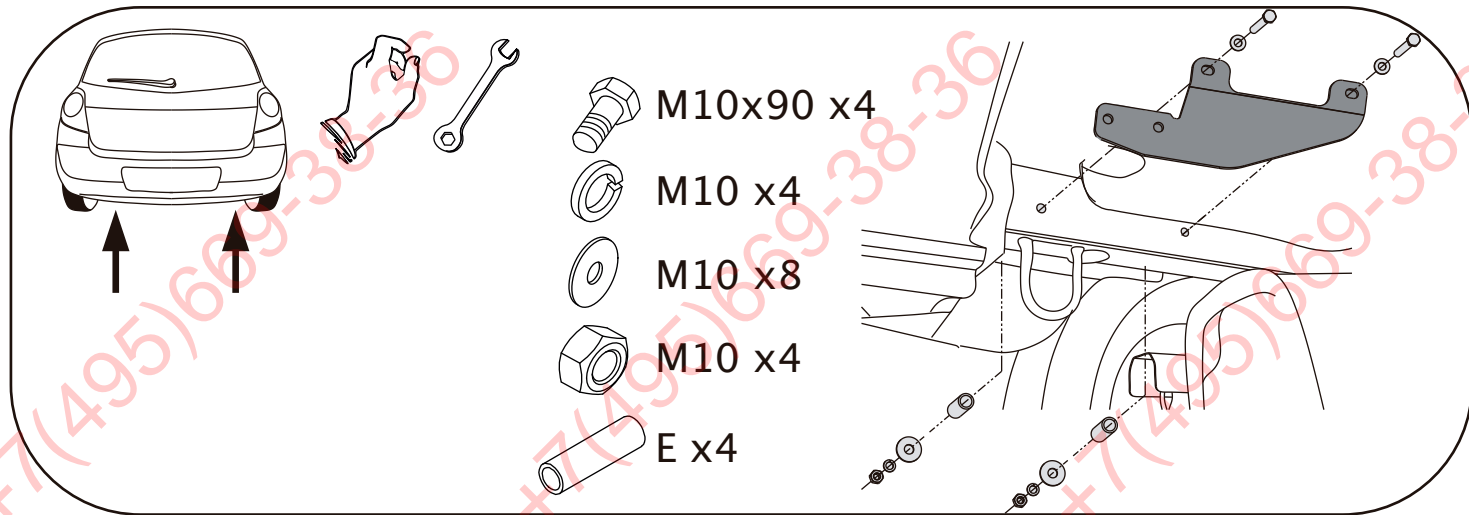

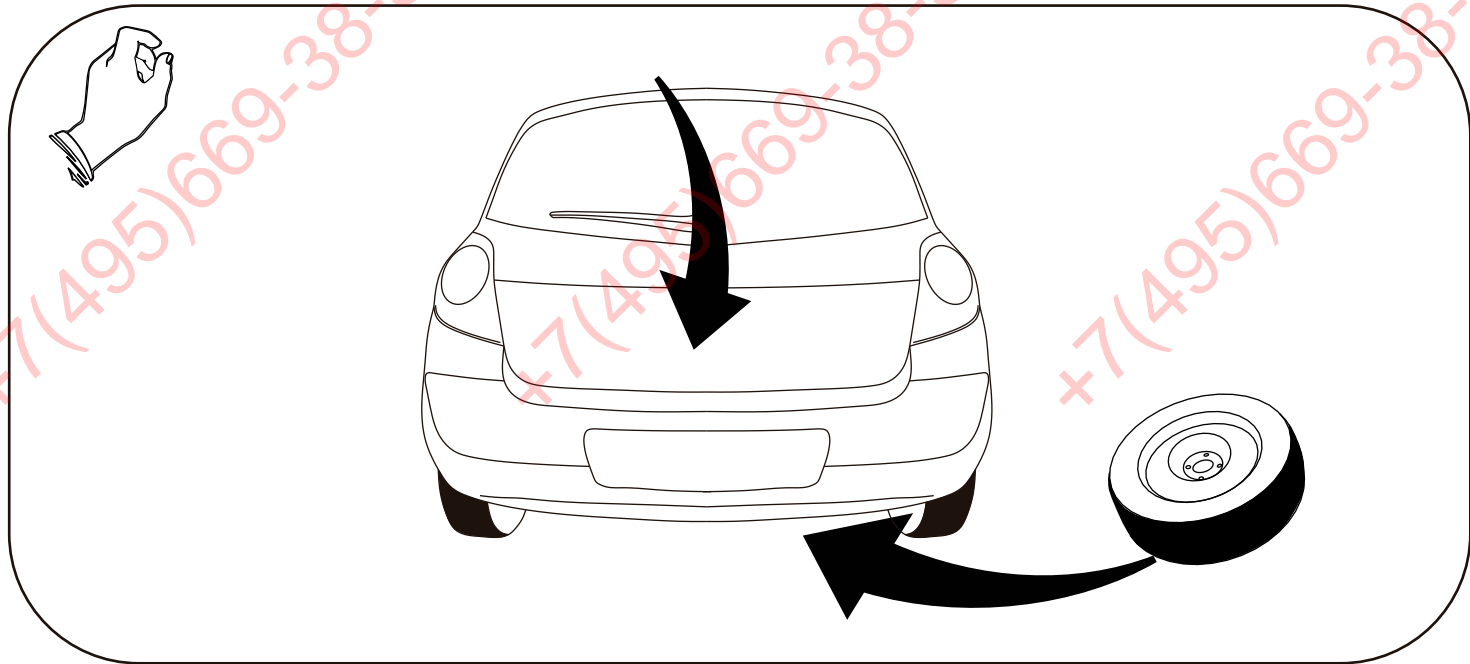

ФАРКОГ.РФ

