

(V113-A) Volkswagen Caddy 2004-...	D(H)	S()	T()	C()
V113-A	6,1	75	1700	1000
D = g* TC/T+C				
S-				
T-				
C-				

(V113-A) Volkswagen Caddy 2004-...
1000 , 80 / .
28248-89 «
37.001.096-93 “

1.	2.	(V113-A) Volkswagen Caddy 2004-...	1
	50		1
	17		1
			1

3.

ФАРКОП.РФ

+7 (495) 669-38-36

12 40(1).

(11,12)

12 40(1)
12 40(1).

(13).

(7).

() .

1.

4.

+7(495)669-38-36

+7(495)669-38-36

+7(495)669-38-36

+7(495)669-38-36

+7(495)669-38-36

+7(495)669-38-36

+7(495)669-38-36

+7(495)669-38-36

+7(495)669-38-36

1 (L/1)	-	11
2 (54/2G)	12 40	2
3 (31/3)	12 90	8
4 (R/4)	12	3
5 (58R/5)	12 1.25	4
6 (54/6)	d 12	17
7 (58L/7)	d 12	4
		1
		2
		1
		1
		1
		1
		4

V 113-A

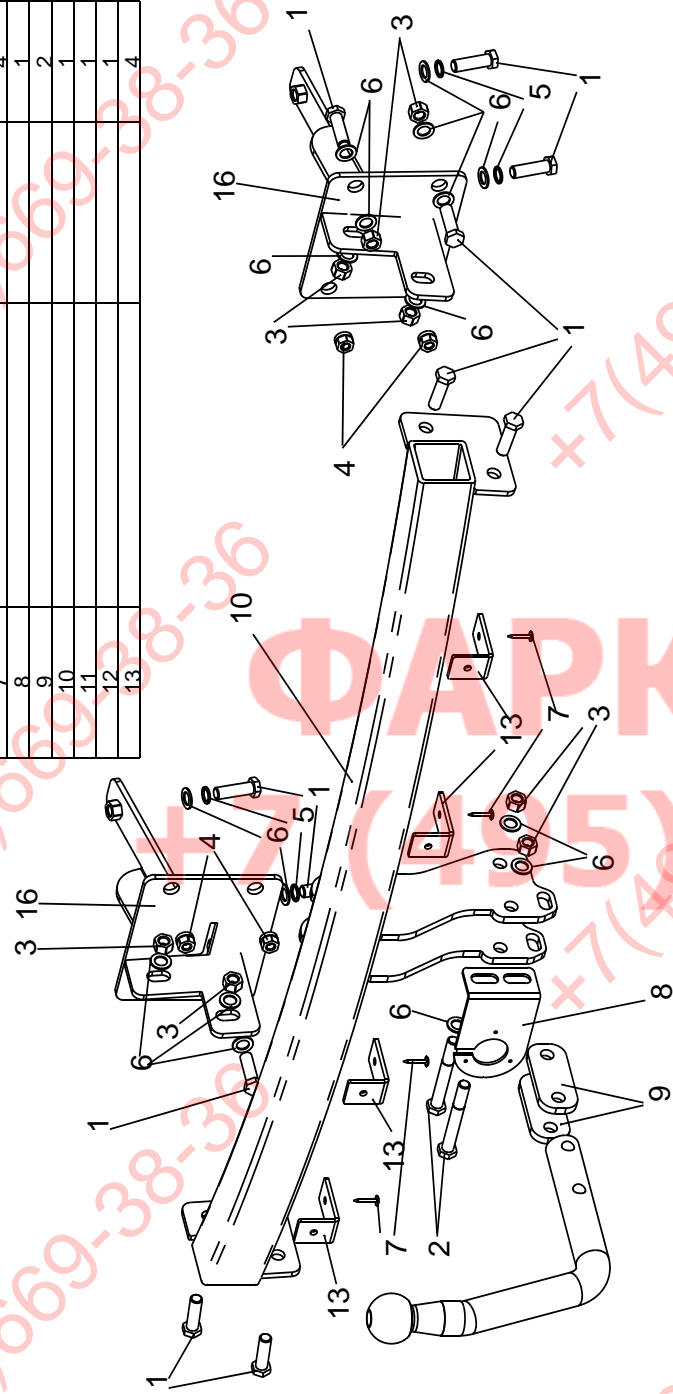

ФАРКОП.РФ

+7(495)669-38-36

+7(495)669-38-36