

bosal

**Инструкция по монтажу
тягово-сцепного устройства
шарового типа 4245 А
для автомобилей
Tagaz Road Partner**

ФАРКОП.РФ

+7 (495) 669-38-36

	2008-...
	1500
	50
	18,0

.....
..... VIN



462800,

« - »
18
: (35363) 7-05-06
/ : (35363) 7-13-20
(495) 799-13-46
www.bosal-autoflex.ru
www.bosal.com

- « - » (8182) 22-48-15
- " 8(8442) 98-74-98
- " " 8(343) 379-39-89, 373-42-73
- " " 8(343) 26-88-308
- " " 8(3952) 710-194
- " " 8(495) 777-54-59
- " " 8(495)745-79-11
- " " 8(495) 788-95-97
- " " 8(495) 720-51-03
- " " 8(3532) 57-99-85
- " " 8-905-899-5012
- " " 8(383) 291-59-60
- " " 8(831) 279-53-24
- " " 8(3422) 98-27-20
- " " 8(342) 220-87-87
- " " 8-927-002-90-06
- " " 8(3462) 24-00-44
- " " 8(3842) 21-14-76
- " " 8-902-940-4151
- " " 8(3452) 32-22-12, 41-52-62
- " " 8-961-213-0278
- " " 8-917-347-1700
- " " 8(351) 269-44-75, 900-72-73
- " " 8(3512) 773-76-91

41.55-2005.

d13.

« »
d18.

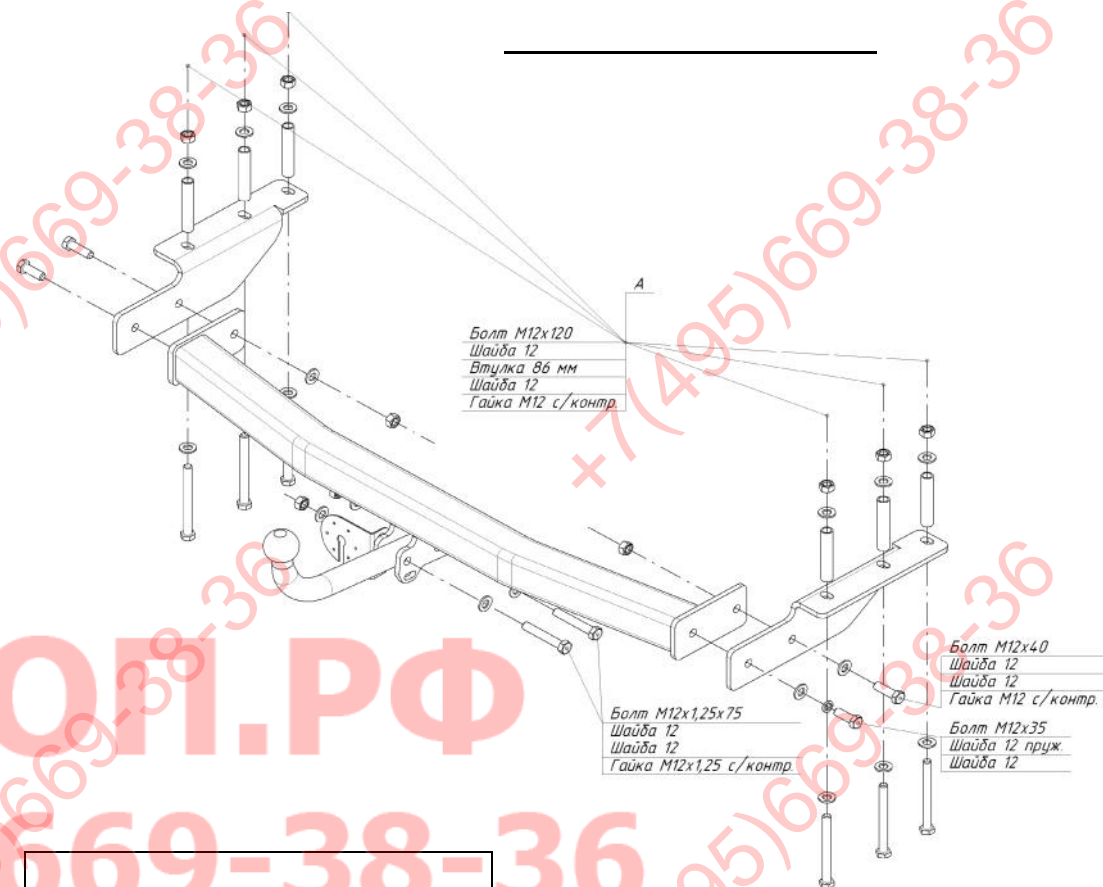

ФАРКОП.РФ

+7 (495) 669-38-36

	1
	1
	1
	1
	1

4	3
4	3
4	3
4 35	3
12 35	2
12 40	2
12 1,25 75	2
12 120	6
12 /	8
12 1,25 /	2
12	2
12	22
VH0701	1
86	6
	1
	1
190	1
	1

