

Fitting instructions
Make: Renault
Megane II; 2002->
Megane III; 2008->
Megane III Coupe (3doors); 2008->
Scenic II; 2003->
Scenic III; 2009->
Grand Scenic ; 2004->
Type: 5125

ФАРКОЛ.РФ

+7 (495) 669-38-36

ser.nr:

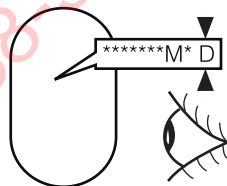

ser.nr:

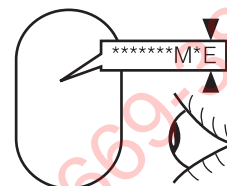

Megane II; 2002->
 Scenic II; 2003->
 Grand Scenic; 2004->
 Scenic III; 2009->
 Megane III; 2008->
 Scenic III; 2009->
 Megane III coupe; 2008->

© 512570/12-02-2010/1

© 512570/12-02-2010/18

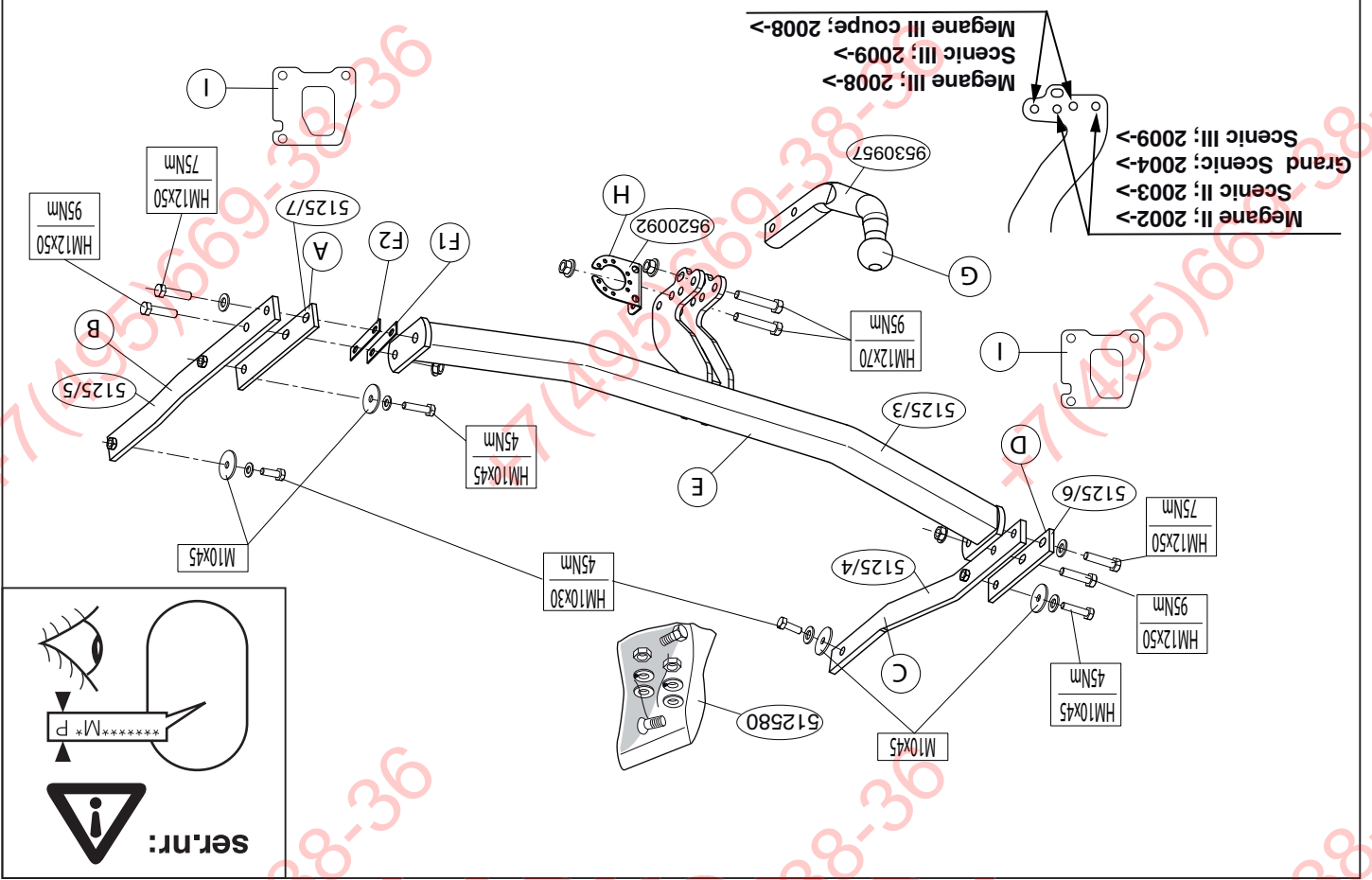

ФАРКОЛ.РФ

+7 (495) 669-38-36

93-88-36 (699) 669-38-36 (564) 7+ (95) 669-38-36 (564) 7+ (95) 669-38-36 (564) 7+

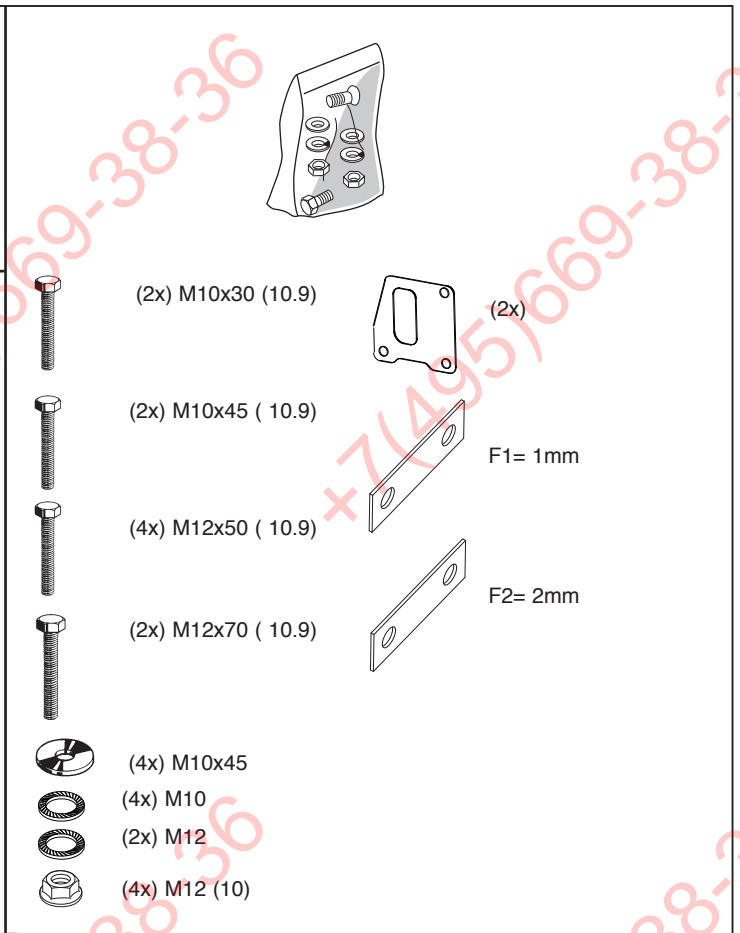
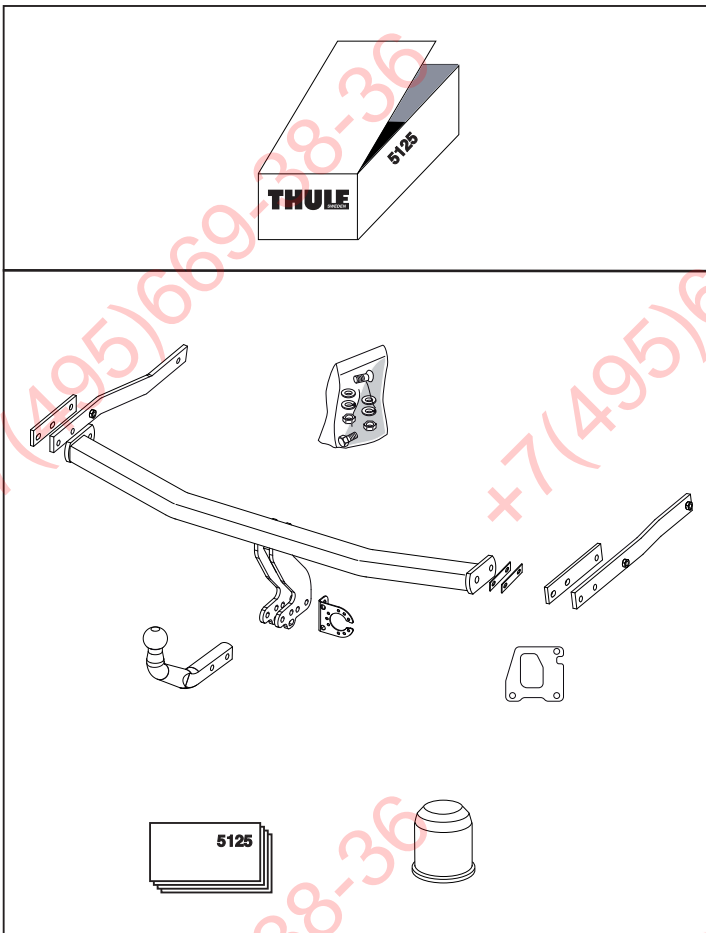

© 512570/12-02-2010/3

ФАРКОП.РФ

+7 (495) 669-38-36

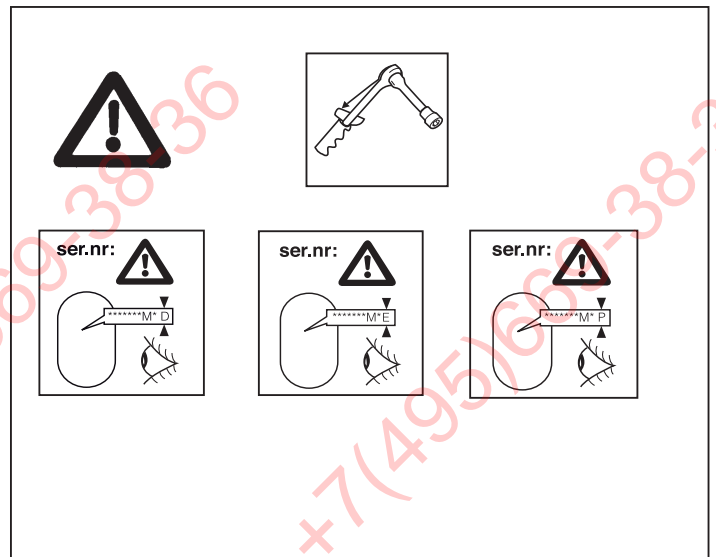
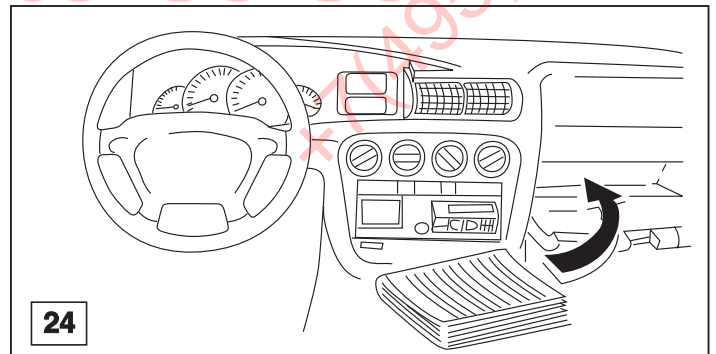
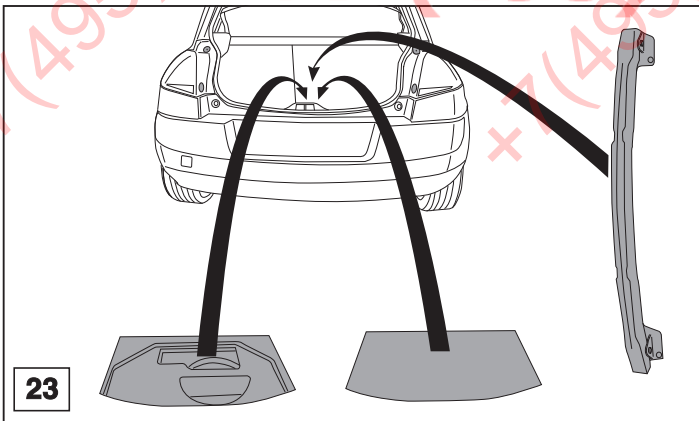

© 512570/12-02-2010/16

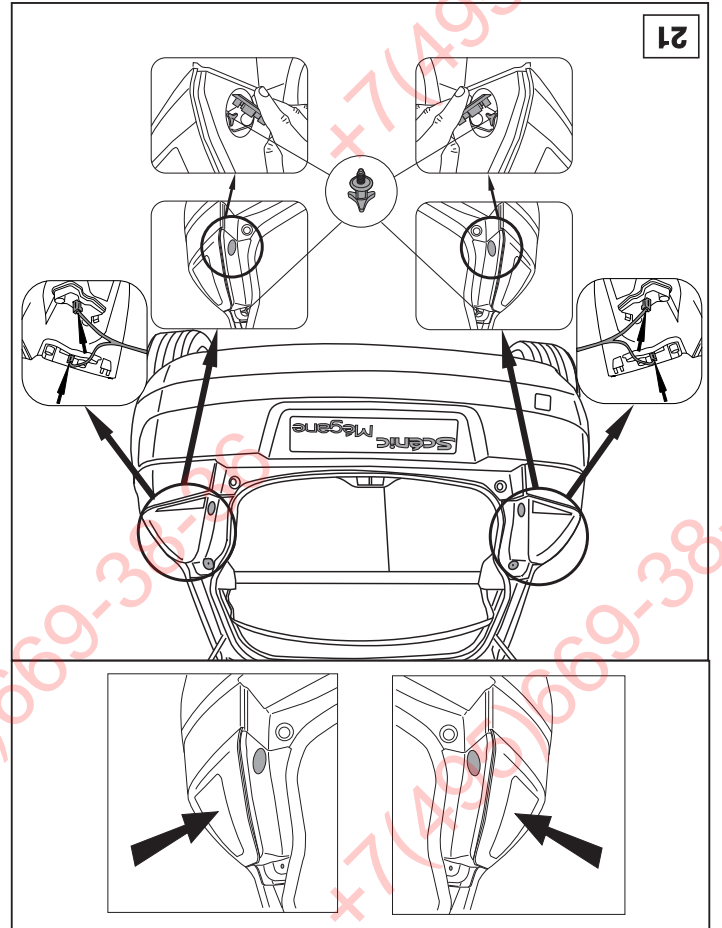
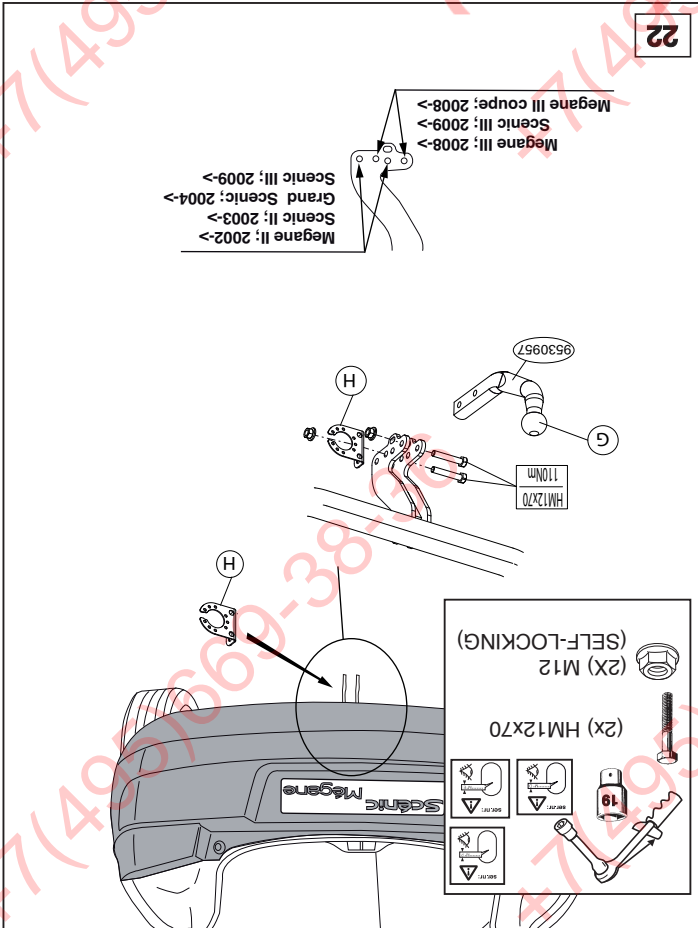
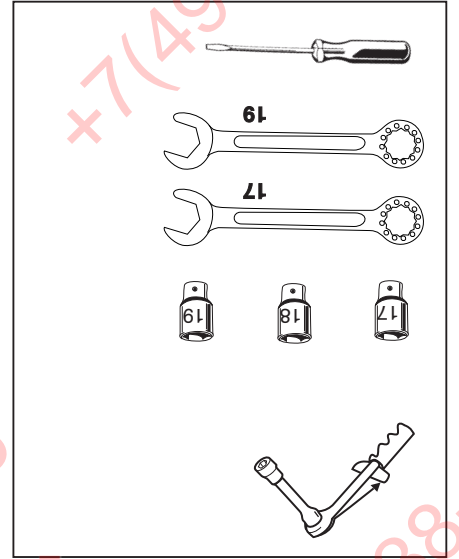
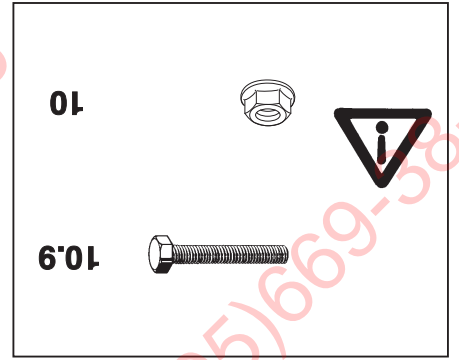
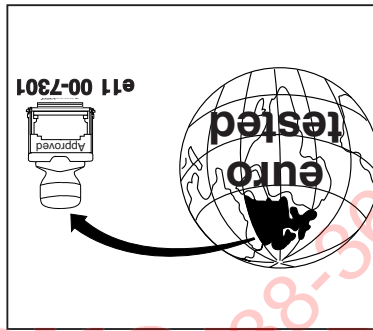
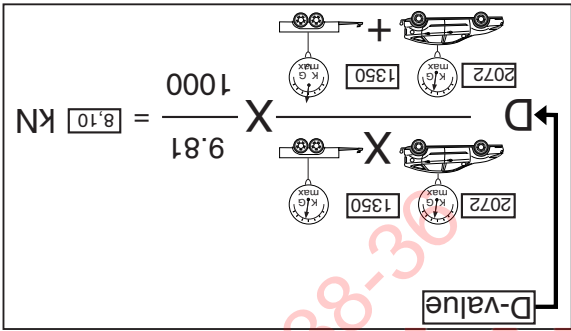
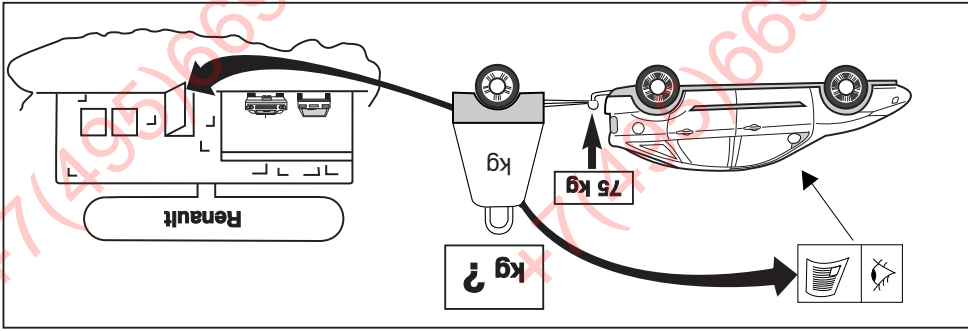

ΦΑΡΚΟΤ.ΡΦ
+7 (495) 669-38-36

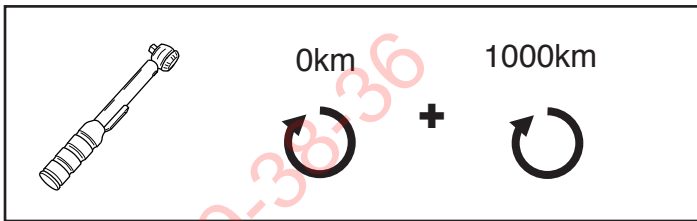

HINWEISE:

- * Die für das Fahrzeug zugelassene Anhängelast ist den Fahrzeug Unterlagen zu entnehmen. Bei Änderungen des Fahrzeuggewichtes muß die höchstzulässige Anhängelast gegebenenfalls aus dem D-Wert nachgerechnet werden.
- Auskunft hierüber kann Ihr Fachhändler oder der TÜV geben.
- * Elektrische Anlage gemäß StVZO anbringen.

ФАРКОП.РФ

© 512570/12-02-2010/5

+7 (495) 669-38-36

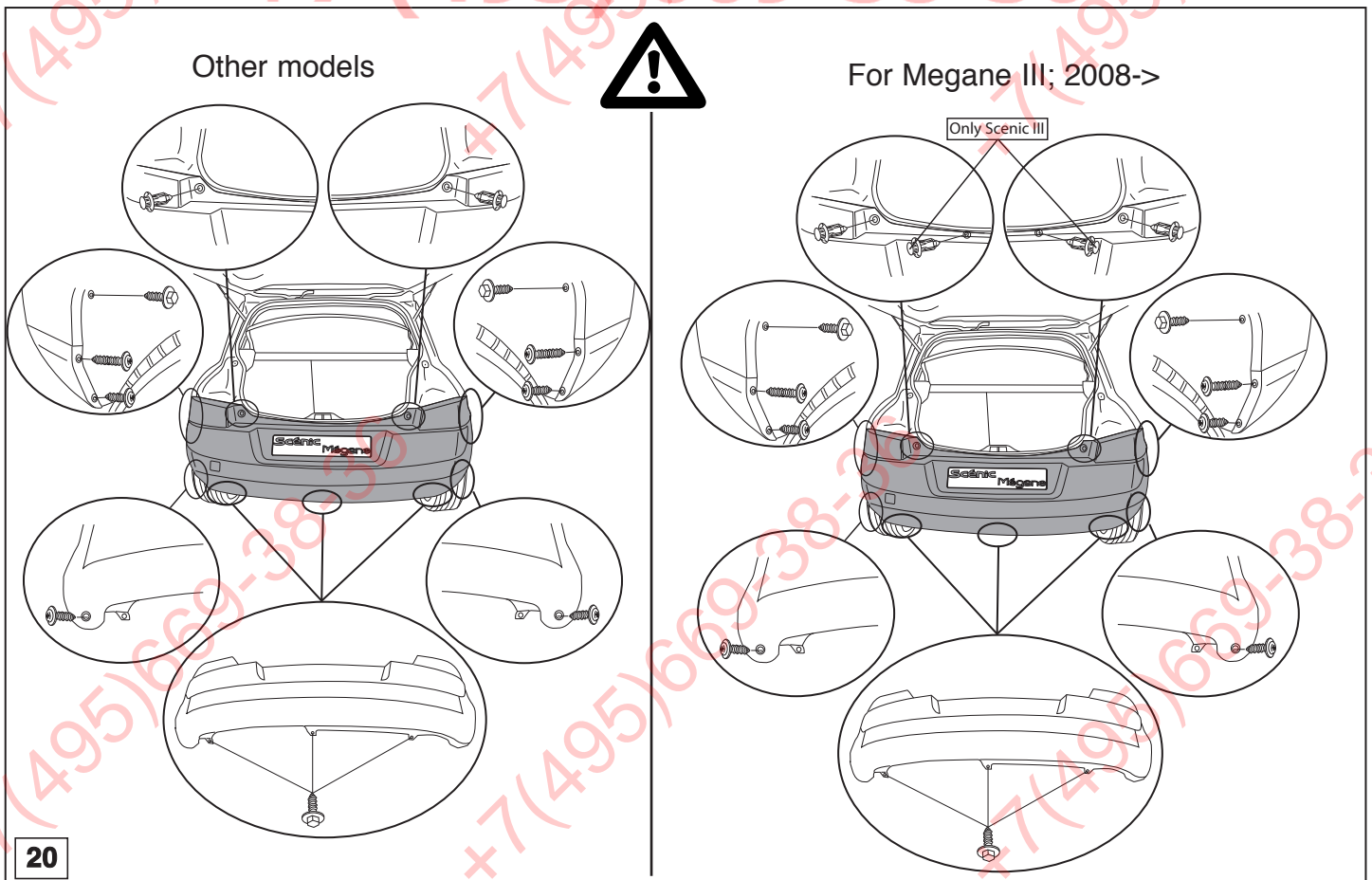

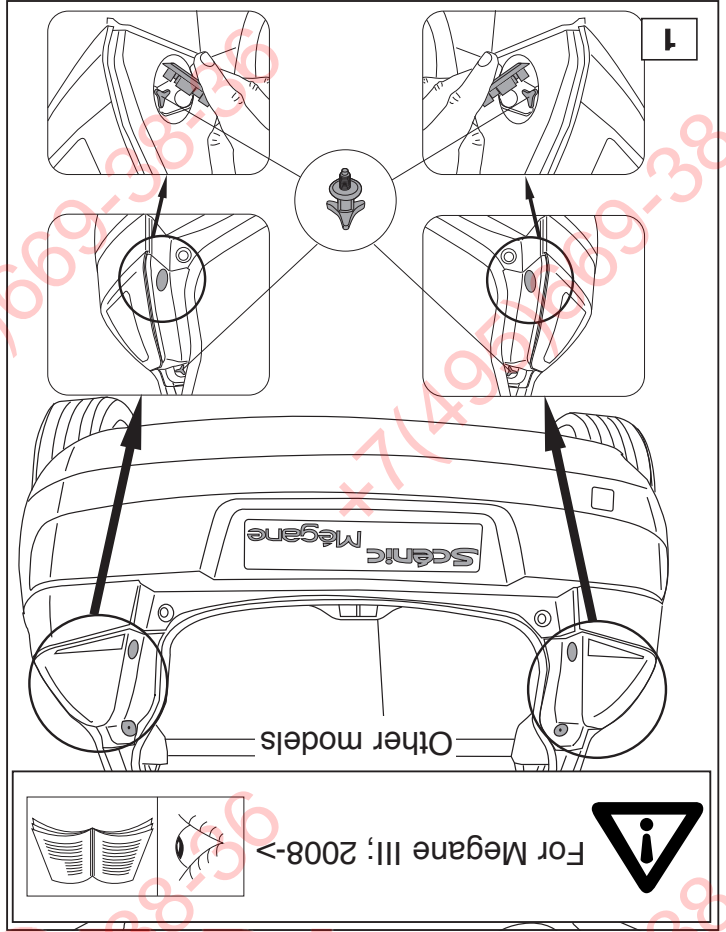
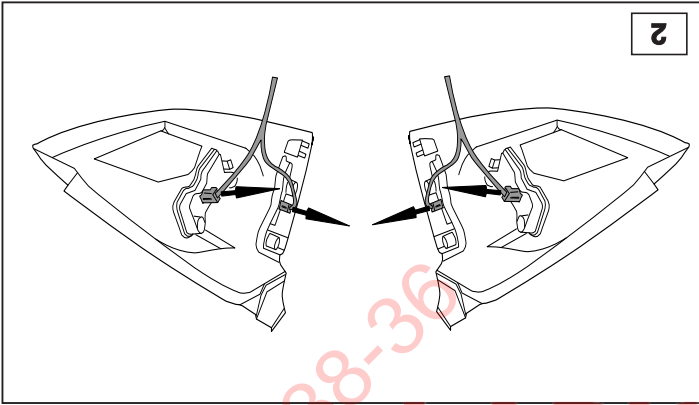
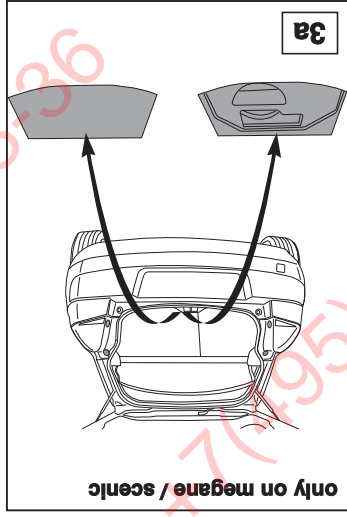
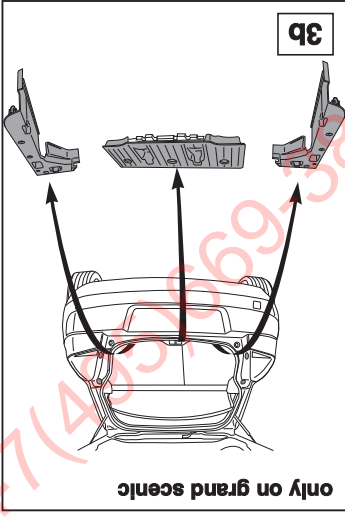

+7 (495) 669-38-36

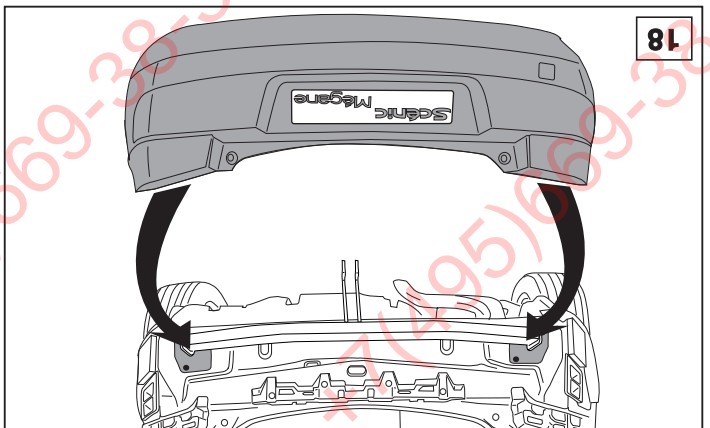
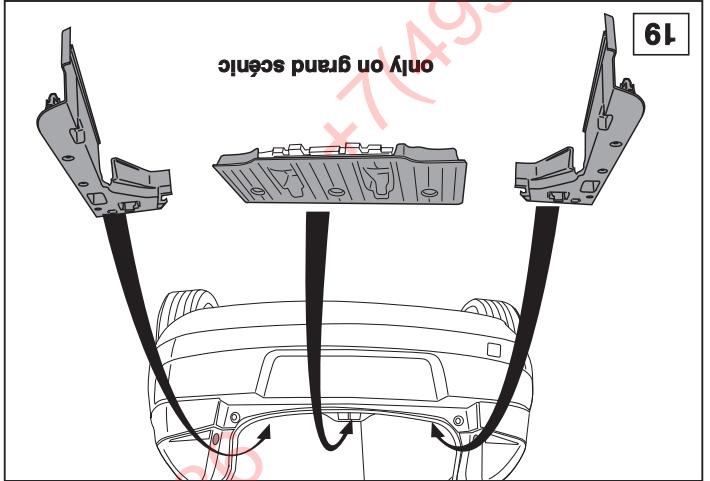

Other models



For Megane III; 2008->

Only Scenic III

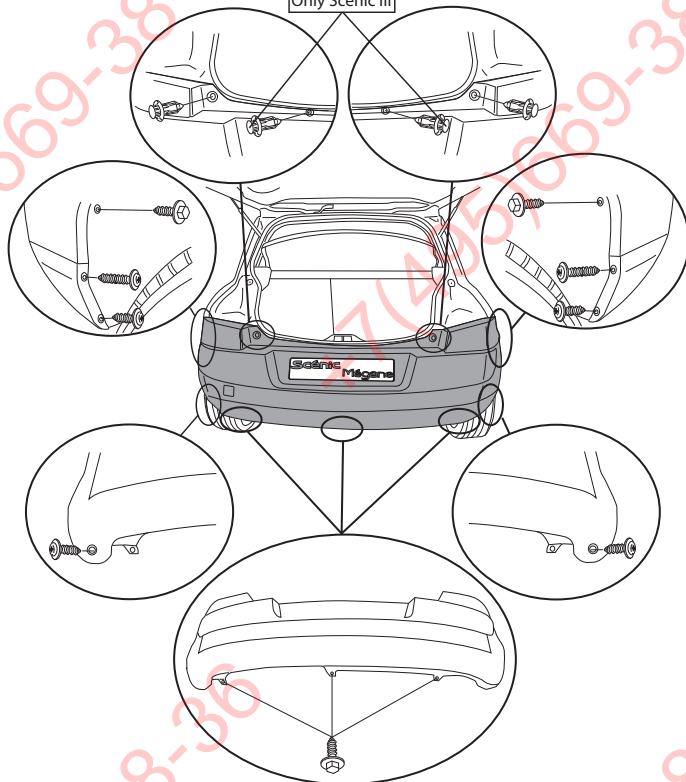
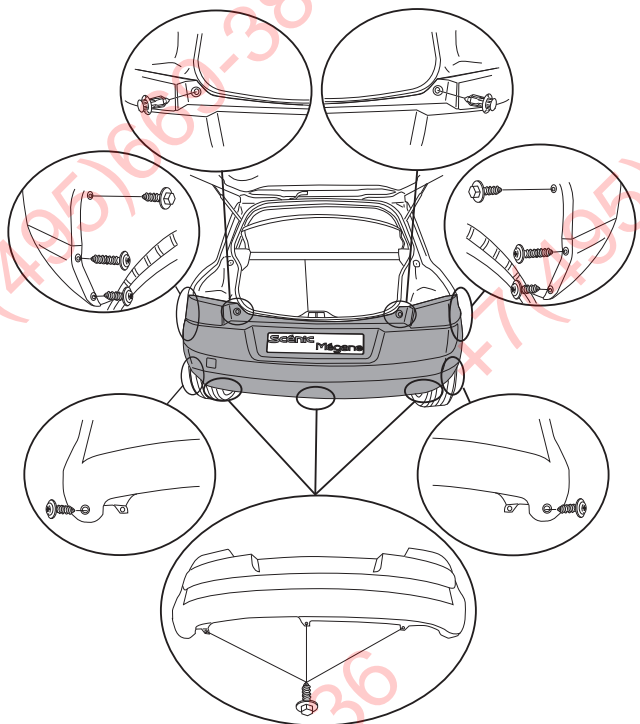

4

© 512570/12-02-2010/7

ΦΑΡΚΟΤ.ΡΦ

+7 (495) 669-38-36

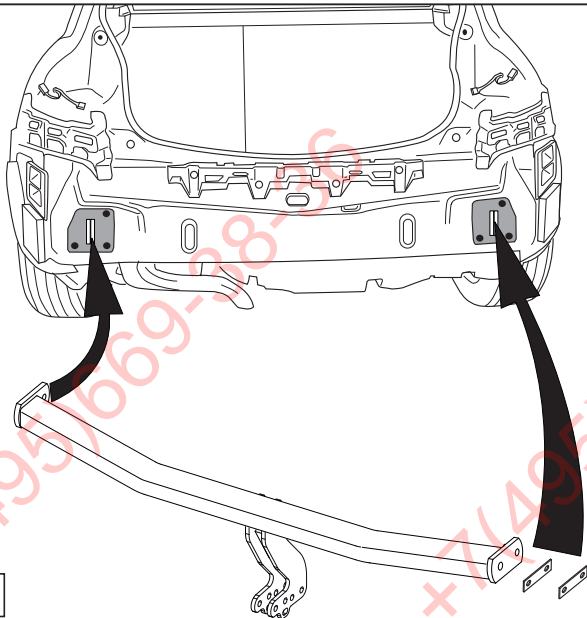
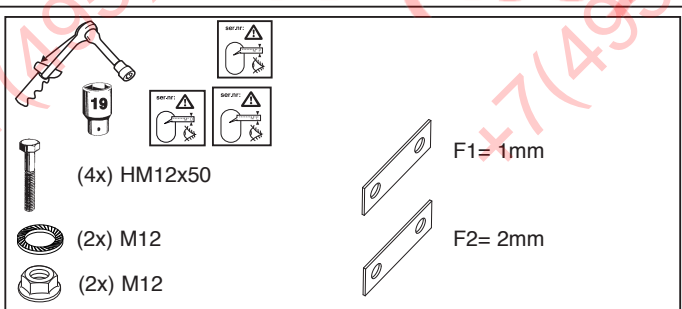

16



only on grand scénic

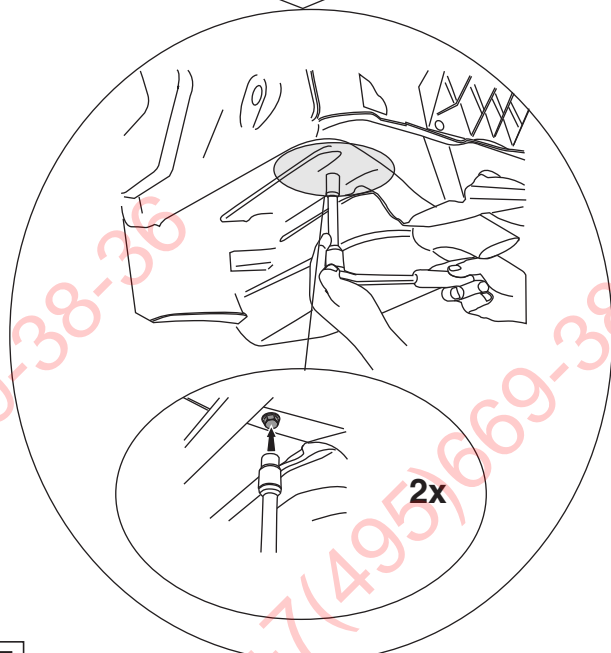
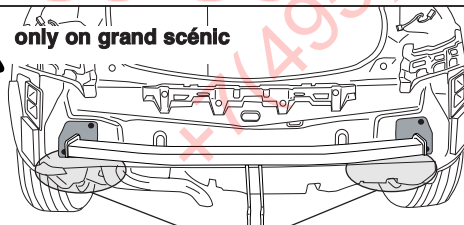

17

© 512570/12-02-2010/12

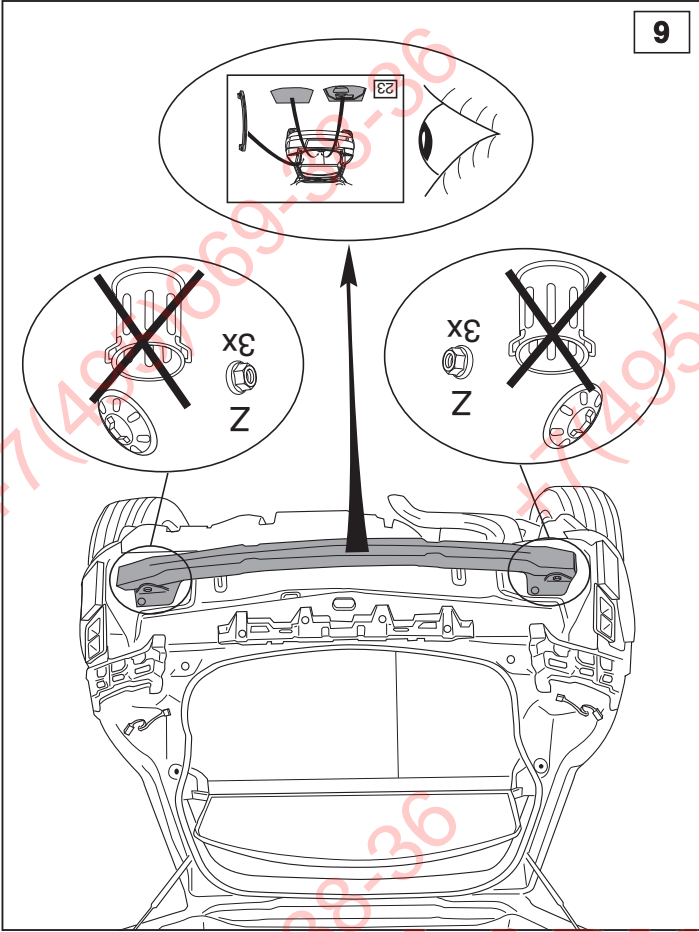

6

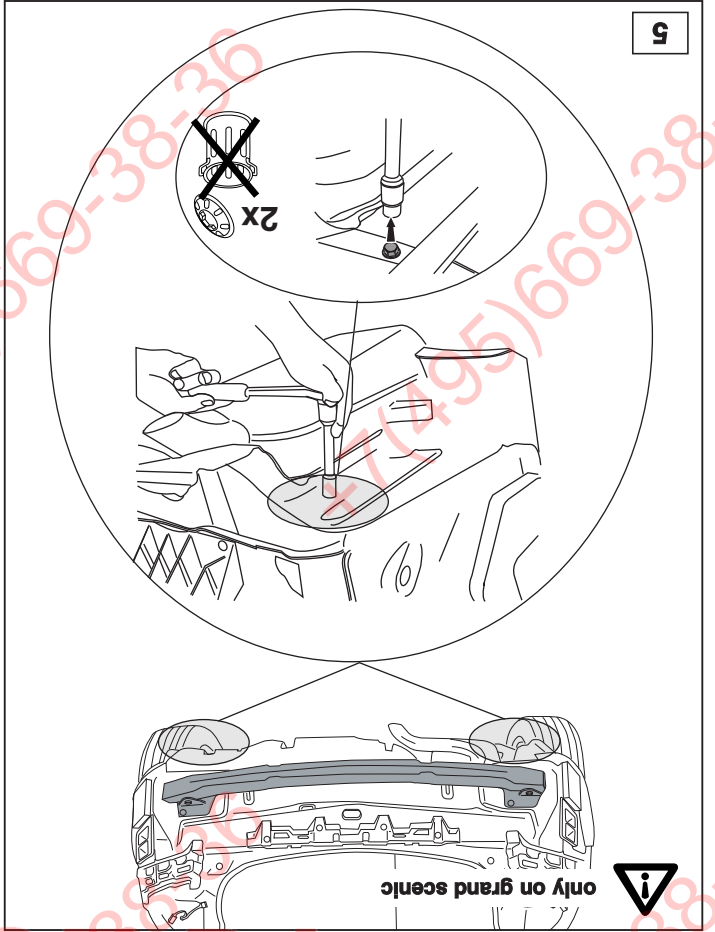

5

only on grand scenic



ФАРКОЛ.РФ

+7 (495) 669-38-36

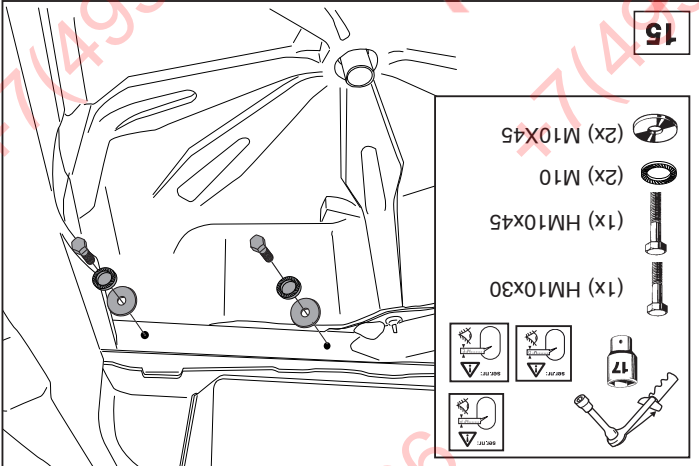

15

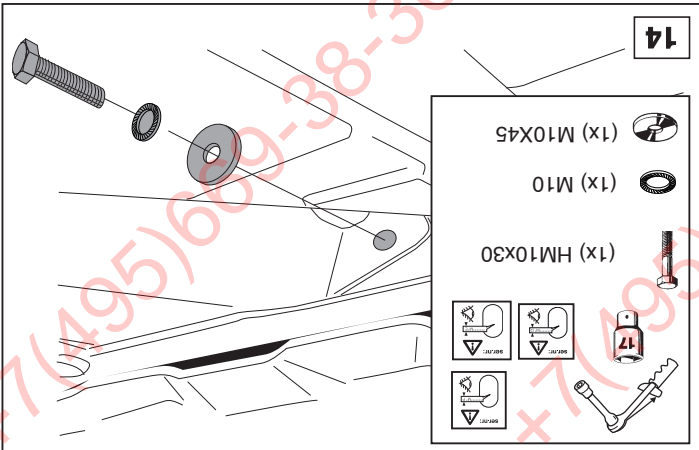

14

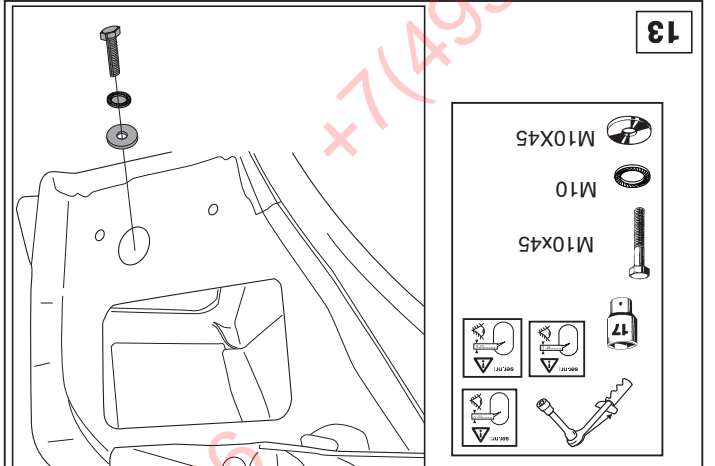

13

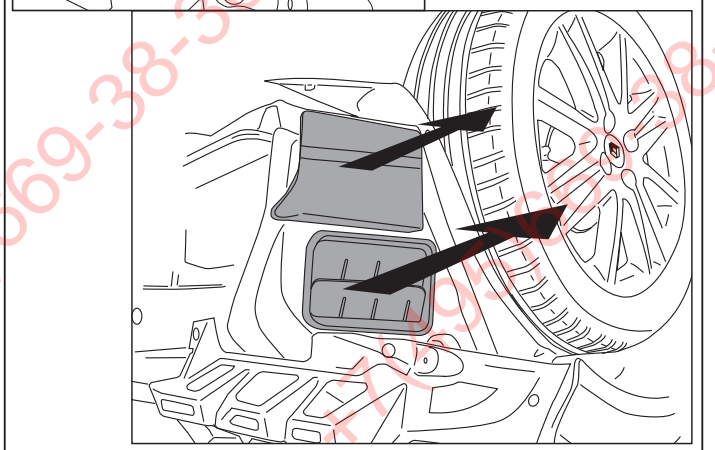

93-88-36-699(599)-699(599)-38-36

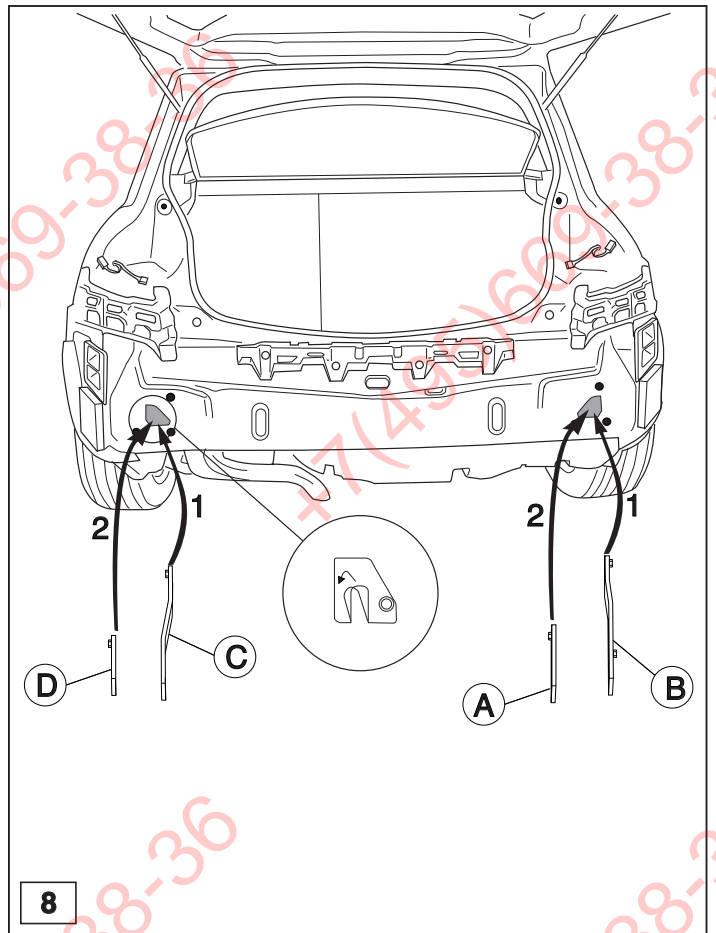
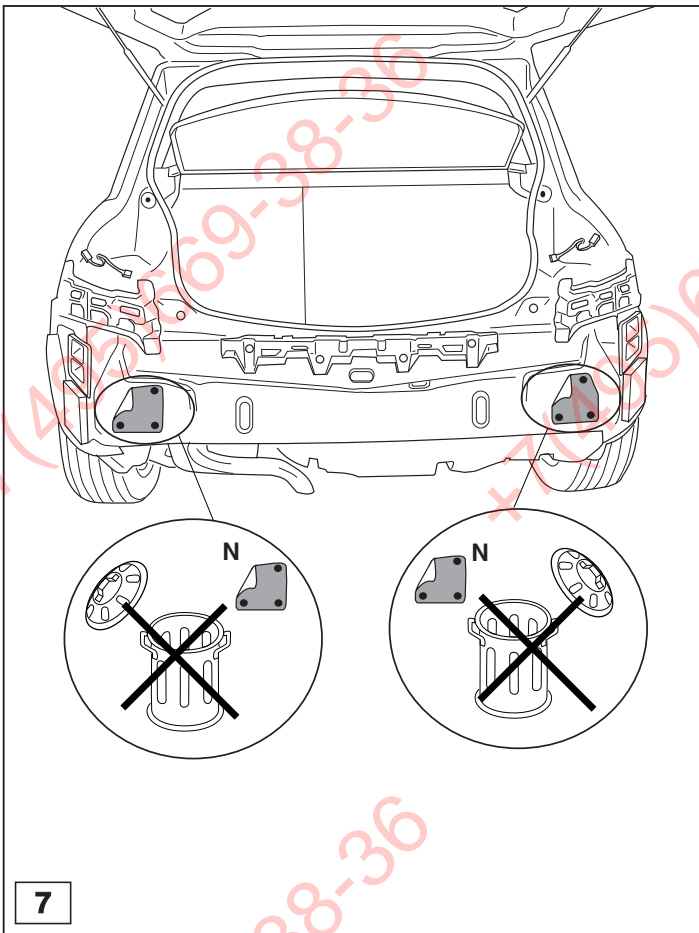

© 512570/12-02-2010/9

ФАРКОП.РФ

+7 (495) 669-38-36

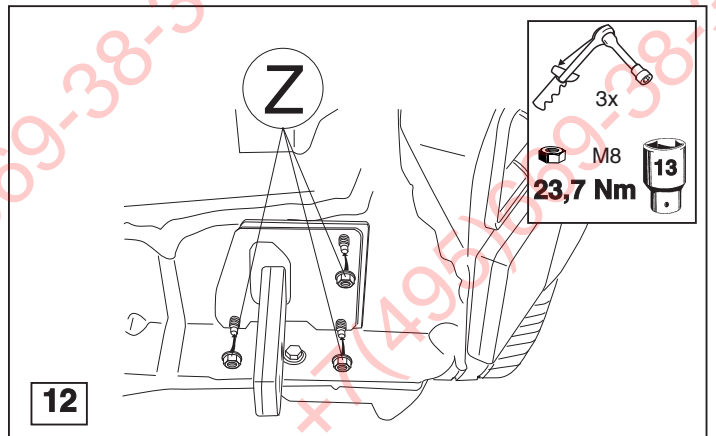
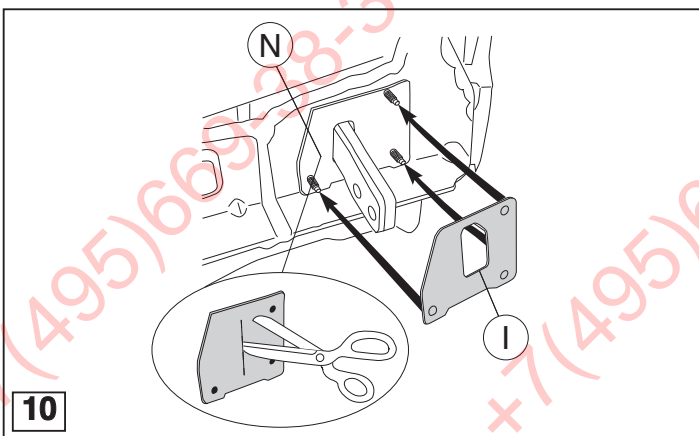
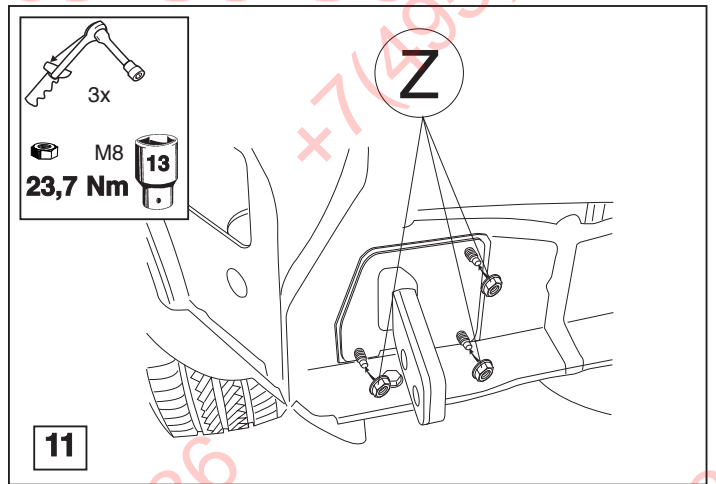
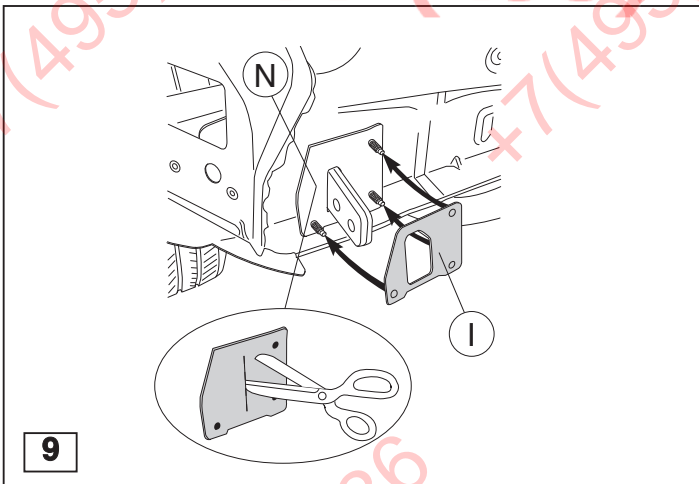

© 512570/12-02-2010/10