

(T104-A) Toyota Camry sedan 2002-2006	D (H)	S ()	T ()	C ()
	T104-A	5,8	75	1500
D = g* TC/T+C				
S-				
T-				
C-				

(T104-A) Toyota Camry sedan 2002-2006
1000
28248-89 «
37.001.096-93 “

80 /

1.		2.	(T104-A) Toyota Camry sedan 2002-2006	1
	50			1
	19			1
				1

1 (L/1)		
2 (54/2G)		
3 (31/3)		
4 (R/4)		
5 (58R/5)		
6 (54/6)		
7 (58L/7)		

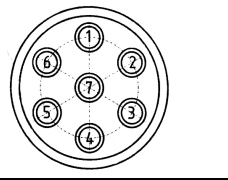

	6																			
1	10 1,25 40																			
2	12 40																			
3	12 90																			
4	10 1,25 6																			
5	12 8																			
6	d 10																			
7	d 10																			
8	d 12																			
9																				
10																				
11																				
12																				
13																				

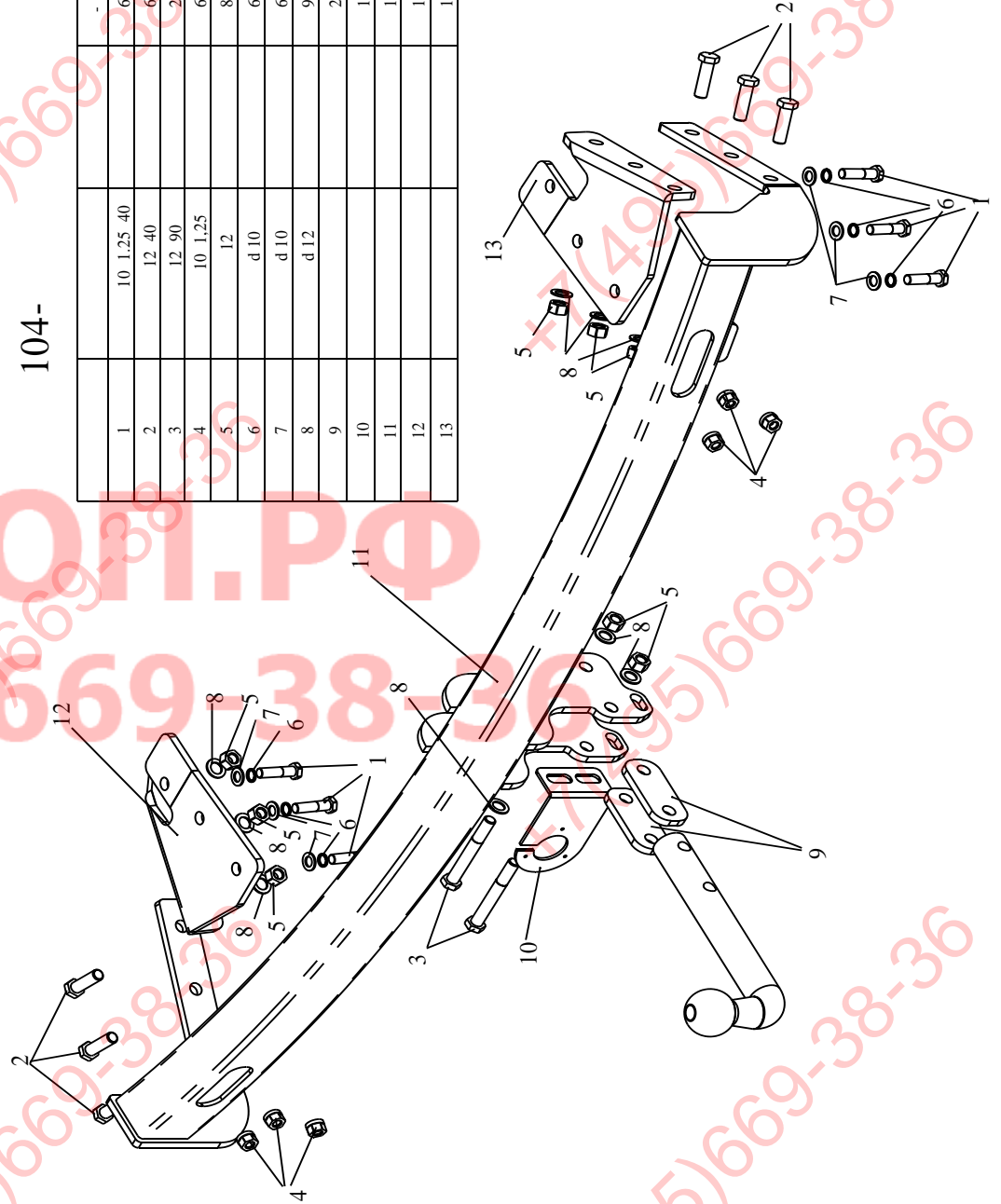

ФАРКОП.РФ

+7 (495) 669-38-36