



Fitting Instructions

TOWBAR VW96U
For Porsche Cayenne
VW Touareg
Audi Q8
2018-

MATERIALS

A	1	Cross Bar
B	2	Brackets
C	4	M8 x 30 x 1.25 pitch Bolts, Plain Washers and Nyloc Nuts
D	2	M6 x 20 x 1.0 pitch Bolts, 2 x Plain Washers and Nyloc Nuts
E	2	M6 x 20 x 1.0 pitch Bolts, and Nyloc Nuts
ZE	1	Retractable Electrical Plate
ZN	1	Neck Kit

FITTING

1. Remove wheel arch liners. (1 x screw at rearmost end and pull outwards to unclip)
2. Un-clip black plastic trim attached to the side of each rear light cluster.
3. Remove Bumper. (1 x screw adjacent to each light cluster, 4 x screws along bottom edge, 3 x screws in each wheel arch liner, 2 x screws each side securing underside liners).
4. Remove aluminium Bumper Beam. (Retain bolts for attachment of tow bar.)
5. Assemble Cross Bar (A) onto rear panel using bumper beam mountings and secure using existing bumper beam bolts (X)
6. Assemble the chosen Neck Option (ZN), and Retractable Electrical Plate (ZE) to Cross Bar (A) using separate Fitting Instructions from each kit.
7. On vehicles which have sensors fastened to the aluminium bumper beam:
8. Remove sensors from aluminium bumper beam
9. Assemble Brackets (B) to each end of Cross Bar (A) using fasteners (C). Adjust to approximately mid-slot.
10. Assemble sensors to Brackets (B) using fasteners (D & E [positions reversed on opposite side]), taking care that they face away from the vehicle as when fitted to the bumper beam.
11. If there isn't an opening in the centre of the bumper already, cut bumper using diagram below as a guide and refit to vehicle.

Recommended torque settings:

Grade 8.8 bolts: M8 - 24Nm, M10 - 52 Nm, M12 - 80 Nm, M14 - 130 Nm, M16 - 200 Nm

Grade 10.9: M12 - 120Nm, M10 - 70Nm M8- 35Nm

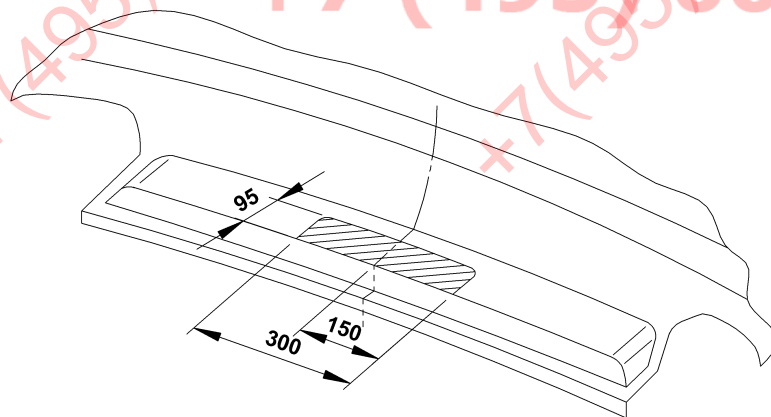

Q8 Bumper Cut

